

APJ ABDUL KALAM
TECHNOLOGICAL
UNIVERSITY

SEMESTER V

KTU



CODE MET301	COURSE NAME MECHANICS OF MACHINERY	CATEGORY	L	T	P	CREDIT
		PCC	3	1	0	4

Preamble:

This course aims to introduce the students to the fundamentals of the kinematics of various mechanisms and also its analysis for its displacement, velocity, and acceleration. The course will also cover the design of cams, theory and analysis of gears, gear trains and synthesis of mechanisms. The static force analysis of planar mechanisms and concept of gyroscopic couple along with its effect has also been included. This course also aids students in estimating unbalance in rotating and reciprocating masses and suggesting methods to overcome it.

Prerequisite: Engineering Mechanics (EST 100)

Course Outcomes: After the completion of the course the student will be able to

CO 1	Explain the fundamentals of kinematics, various planar mechanisms and interpret the basic principles of mechanisms and machines
CO 2	Perform analysis and synthesis of mechanisms
CO 3	Solve the problem on cams and gear drives, including selection depending on requirement.
CO 4	Calculate the gyroscopic effect in various situations
CO 5	Analyse rotating and reciprocating masses for its unbalance

Mapping of course outcomes with program outcomes

	PO 1	PO 2	PO 3	PO 4	PO 5	PO 6	PO 7	PO 8	PO 9	PO 10	PO 12
CO 1	2										
CO 2	3	3	3	2	2						
CO 3	3	3	2	2	2						
CO 4	3	2	1	1	1						
CO 5	3	2	2	1	2						

Assessment Pattern

Bloom's Category	Continuous Assessment Tests		End Semester Examination
	1	2	
Remember	10	10	10
Understand	20	20	20
Apply	20	20	70
Analyse			
Evaluate			
Create			

Mark distribution

Total Marks	CIE	ESE	ESE Duration
150	50	100	3 hours

Continuous Internal Evaluation Pattern:

Attendance	: 10 marks
Continuous Assessment Test (2 numbers)	: 25 marks
Assignment/Quiz/Course project	: 15 marks

End Semester Examination Pattern: There will be two parts; Part A and Part B. Part A contain 10 questions with 2 questions from each module, having 3 marks for each question. Students should answer all questions. Part B contains 2 questions from each module of which student should answer any one. Each question can have maximum 2 sub-divisions and carry 14 marks.

Course Level Assessment Questions

Course Outcome 1 (CO1): Explain the fundamentals of kinematics, various planar mechanisms and their components

1. Define the terms Link, Kinematic chain, Mechanism & Machine.
2. Explain Grashof's law.
- 3 Apply Kutzbach criterion to find the mobility of mechanisms.

4. Sketch and explain the various inversions of slider crank chain/fourbar chain

Course Outcome 2 (CO2) : Perform analysis and synthesis of mechanisms

1. Find out the velocity and acceleration of links of various planar mechanisms
2. State and prove the Arnold Kennedy's three centre theorem
2. Derive an expression for the magnitude and direction of Coriolis component of acceleration
3. Design a four bar mechanism to generate a given function accurate upto 3 positions
4. Do the static force analysis of four bar/slider crank mechanisms with different loading conditions

Course Outcome 3 (CO3): Solve the problem on cams and gear drives, including selection depending on requirement

1. Why is a roller follower preferred over knife edge follower
2. Design a cam profile to suit the situations for the follower such as SHM, dwell, constant velocity, uniform acceleration cycloidal motion etc
3. What do you understand by the term "interference" as applied to gears
4. Find out the gear train values of simple ,compound and epicyclic gear trains

Course Outcome 4 (CO4): Calculate the gyroscopic effect in various situations

1. What do you understand by Gyroscopic couple? Derive its formula for its magnitude.
2. Explain the effect of the gyroscopic couple on the reaction of the four wheels of a vehicle negotiating a curve.
3. Describe the working of a gyroscope.
4. How does gyroscopes help in guidance?

Course Outcome 5 (CO5): Analyse rotating and reciprocating masses for its unbalance

1. Distinguish between static balancing and dynamic balancing
2. Find out the magnitude and position of balancing masses required to balance unbalanced masses rotating in different planes.
3. What do you mean by primary and secondary unbalanced forces?
4. Find out the value of unbalanced primary force, primary couple, secondary force and secondary couple.

MODEL QUESTION PAPER

APJ ABDUL KALAM TECHNOLOGICAL UNIVERSITY

FIFTH SEMESTER B. TECH DEGREE EXAMINATION

Course Code: MET301

Course Name: MECHANICS OF MACHINERY

Max. Marks: 100

Duration: 3 Hours

PART – A

(ANSWER ALL QUESTIONS, EACH QUESTION CARRIES 3 MARKS)

1. Find out the degree of freedom in the following cases.



a) A planar link

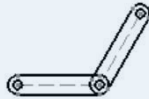

b) Two planar links joined by a revolute joint



c) Three Planar links joined by three revolute joints

2. Describe the motion of the following items as pure rotation, pure translation or complex planar motion.
- a) The hand of a clock b) The pen in an XY plotter c) connecting rod of an IC engine
3. A rod of length 1m with its one end fixed at origin is oriented in the positive X direction. It rotates in the XY plane with an angular velocity of 10rad/s clockwise direction and angular acceleration of 10rad/s^2 in the counter clockwise direction at a particular instant. Find out the total acceleration experienced at the free end.
4. Obtain the expression for velocity when the cam follower motion is cycloidal in nature.
5. How do we bring interchangeability of gears?
6. What do you mean by type synthesis?
7. Define the term 'friction circle'
8. How does a gyroscope help in guidance of aircrafts?
9. Does a rotor which is statically balanced require dynamic balancing?

10. Why do we go for partial balancing in the case of balancing of reciprocating masses?

Part B

(ANSWER ONE FULL QUESTION FROM EACH MODULE)

MODULE – I

11. a) Draw the inversions of the mechanism shown in Figure 1 which leads to double crank, double rocker and crank rocker mechanisms. Describe the nature of motion of each link in each case also **(9 marks)**

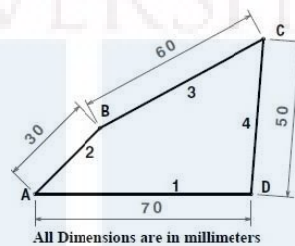

Figure-1

- b) What are binary, ternary and quaternary links? **(5 marks)**

12. In the figure 2 given below the angular velocity of the crank OA is 600 r.p.m. Determine the linear velocity of the slider and angular velocity of all other links. The dimensions of various links are: OA=28 mm; AB = 44 mm; BC = 49 mm and BD = 46 mm. The centre distance between centres of rotation O and C is 65mm. The path of travel of slider is 11 mm below the fixed-point C **(14 marks)**

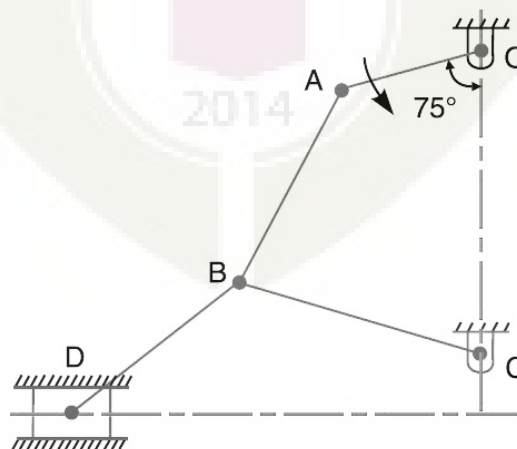

Figure-2

MODULE – II

13. a) What is meant by Coriolis component of acceleration. In which case does it occur?

How is its direction determined? **(9 marks)**

b) A link OB rotating with a constant angular velocity of 2 rad/s in the counter clockwise direction and a block is sliding radially outwards on it with a uniform velocity of 0.75 m/s with respect to the rod as shown in the figure 3 below. Given OA = 1 m and link OB is inclined to the positive X axis by 45° . Find out the absolute acceleration of block at A in magnitude and direction. **(5 marks)**

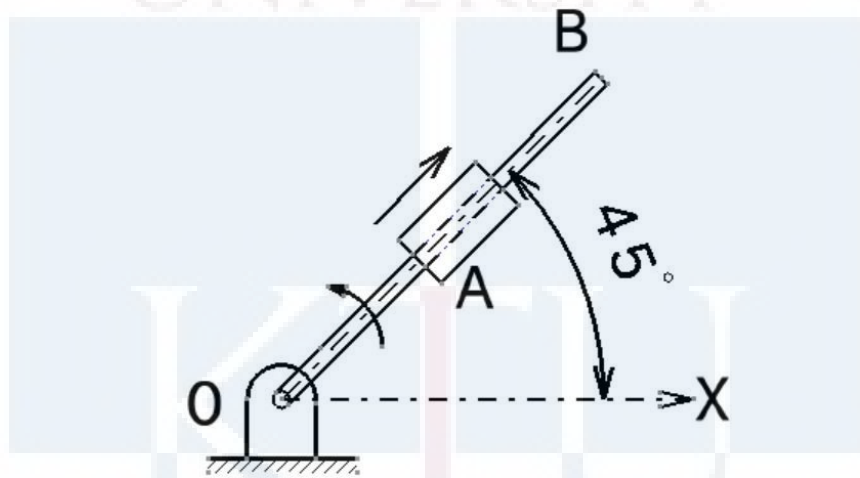

Figure-3

14. A cam rotating at 150 rpm operates a reciprocating follower of radius 2.5 cm. The follower axis is offset by 2.5 cm to the right. The least radius of the cam is 5 cm and the stroke of the follower is 5 cm. ascent and descent with take place by uniform acceleration and retardation. Ascent take place during 75° and descent during 90° of cam rotation. Dwell between ascent and descent is 60° . Draw the cam profile. Also sketch velocity and acceleration diagrams and mark salient values. **(14 marks)**

MODULE – III

15. In an epicyclic gear train as shown in Figure 4 the internal wheels A and B and the compound wheels C & D rotate independently about axis O. The wheels E and F rotate on pins fixed to the arm G. E gears with A and C and F gears with B and D. All wheels have the same module and the number of teeth are:

$$T_C = 28, T_D = 26, T_E = T_F = 18$$

- i) Sketch the arrangement
- ii) Find the number of teeth on A and B
- iii) If the arm G makes 100 r.p.m clockwise and A is fixed, find the speed B
- iv) If the arm G makes 100 r.p.m clockwise and wheel A makes 10 r.p.m counter clockwise, find the speed of wheel B **(14 marks)**

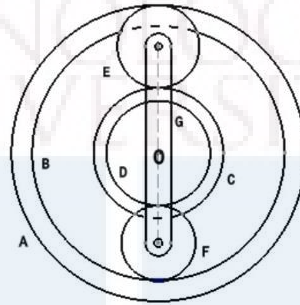

Figure-4

16. a) Design a four bar crank rocker to give 45° of rocker motion with a time ratio of 1:1.25 with 45° output rocker motion. **(9 marks)**
- b) Design a slider crank mechanism to coordinate two positions of the input link and the slider for the following angular and linear displacement of the input link and slider respectively.

$$\theta_{12} = 30^\circ \text{ \& } S_{12} = 100 \text{ mm} \quad \textbf{(5 marks)}$$

MODULE – IV

17. The applied load on the piston of an offset slider-crank linkage shown in Fig. is 100 N, and the coefficient of friction between the slider and the guide is 0.27, using any method, determine the magnitude and sense of torque T_2 applied on OA for the static equilibrium of the linkage. **(14 marks)**

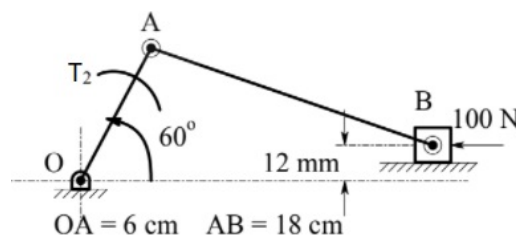

Figure-5

- 18 a) The wheels of a motor cycle have a moment of inertia of 5 kg m^2 and the engine parts, a moment of inertia of 0.35 kgm^2 . The wheel axles and the crank shaft of the engine are all parallel to each other. If the ratio of reduction gears is 4:1, the wheel diameter is 700 mm, determine the magnitude and direction of the gyroscopic couple when the motor cycle negotiates a curve of 50 m radius at a speed of 50 km/hr. If the mass of the motor cycle with rider is 250 kg with centre of gravity at 65 cm above the ground in vertical position, determine the speed of the motor cycle rounding a curve of 60 m if the road condition permits an angle of heel of 45° . **(10 marks)**
- b) Explain spin vector, precession vector, gyroscopic applied torque vector and gyroscopic reactive torque vector. **(4 marks)**

MODULE – V

19. A shaft carries four masses A, B, C and D which are placed in parallel planes perpendicular to the longitudinal axis. The unbalanced masses at planes B and C are 3.6 kg and 2.6kg respectively and both are assumed to be concentrated at a radius of 25mm while the masses in planes A and D are both at a radius of 40mm. The angle between the planes B and C is 100° and that between B and A is 190° , both angles being measured in counter clock wise direction from the plane B. The planes containing A and B are 250mm apart and those containing B and C are 500mm. If the shaft is to be completely balanced, determine

- i) Masses at the planes A and D
 - ii) the distance between the planes C and D
 - iii) the angular position of the mass D
- (14 marks)**

20. A five cylinder in-line engine running at 750 r.p.m. has successive cranks 144° apart, the distance between the cylinder centre lines being 375 mm. The piston stroke is 225mm and the ratio of the connecting rod to the crank is 4. Examine the engine for balance of primary and secondary forces and couples. Find the maximum values of these and the position of the

central crank at which these maximum values occur. The reciprocating mass for each cylinder is 15 kg. (14 marks)

Syllabus

Module 1

Introduction to kinematics and mechanisms - various mechanisms, kinematic diagrams, degree of freedom- Grashof's criterion, inversions, coupler curves mechanical advantage, transmission angle. straight line mechanisms exact, approximate. Displacement, velocity analysis- relative motion - relative velocity. Instantaneous centre -Kennedy's theorem.

Module 2

Acceleration analysis- Relative acceleration - Coriolis acceleration - graphical and analytical methods.

Cams - classification of cam and followers - displacement diagrams, velocity and acceleration analysis of SHM, uniform velocity, uniform acceleration, cycloidal motion Graphical cam profile synthesis, pressure angle.

Module 3

Gears – Classification- terminology of spur gears – law of gearing -tooth profiles- involute spur gears- contact ratio - interference - backlash - gear standardization – interchangeability. Gear trains - simple and compound gear trains - planetary gear trains.

Kinematic synthesis (planar mechanisms) - type, number and dimensional synthesis – precision points. Graphical synthesis for motion - path and prescribed timing - function generator. 2 position and 3 position synthesis – overlay Method. Freudenstein's equation.

Module 4

Static force analysis- Analysis of four bar linkages and slider crank mechanism, graphical method, Matrix method, principle of virtual work. Analysis of four bar and slider crank mechanisms with sliding and pin friction.

Gyroscopic couples-spin, precession and applied gyroscopic couple vectors-effects on the stability of two wheelers, four wheelers, sea vessels and air crafts, application of gyroscopes

Module 5

Static balancing-dynamic balancing-balancing of several masses in the same plane-several masses in different planes-graphical and analytical method-force and couple polygons.

Balancing of reciprocating masses -Single cylinder engine-multi cylinder engine -V-engine

Text Books

1. Ballaney P. L., Theory of Machines and Mechanisms, Khanna Publishers,2005
2. S. S. Rattan, Theory of Machines, Tata Mc Graw Hill,2009

Reference Books

1. C. E. Wilson, P. Sadler, Kinematics and Dynamics of Machinery, Pearson Education,2005.
2. D.H. Myszka, Machines and Mechanisms Applied Kinematic Analysis, Pearson Education,2013
3. G. Erdman, G. N. Sandor, Mechanism Design: Analysis and synthesis Vol I & II, Prentice Hall of India,1984.
4. Ghosh, A. K. Malik, Theory of Mechanisms and Machines, Affiliated East West Press,1988
5. J. E. Shigley, J. J. Uicker, Theory of Machines and Mechanisms, McGraw Hill,2010
6. Norton, Kinematics and Dynamics of Machinery, Tata McGraw Hill,2009

Course Contents and Lecture Schedule

No	Topic	No. of lectures
1	Module-1-	10 Hours
1.1	Introduction to kinematics and mechanisms	1 Hr
1.2	Various mechanisms	2 Hr
1.3	Kinematic diagrams, degree of freedom, Grashof's criterion	2 Hr
1.4	Inversions	1 Hr
1.5	Coupler curves mechanical advantage, transmission angle.	1 Hr
1.6	Straight line mechanisms exact, approximate	1 Hr
1.7	Displacement, velocity analysis, Kennedy's theorem.	2 Hr
2	Module 2-	10 Hours

2.1	Acceleration analysis- Relative acceleration - Coriolis acceleration -	1 Hr
2.2	Graphical and analytical methods.	2Hr
2.3	Cams - classification of cam and followers	1 Hr
2.4	Displacement diagrams, velocity and acceleration analysis of SHM,	2 Hr
2.5	Uniform velocity, uniform acceleration and cycloidal motion	1 Hr
2.5	Graphical cam profile synthesis, pressure angle.	2 Hr
2.6	Analysis of tangent cam with roller follower and circular cam with flat follower	1 Hr
3	Module-3	9 Hours
3.1	Gears – terminology of spur gears – law of Gearing	1 Hr
3.2	involute spur gears - contact ratio- interference - backlash - gear standardization-interchangeability	1 Hr
3.3	Gear trains - simple and compound gear trains - planetary gear trains	2 Hr
3.4	Kinematic synthesis (planar mechanisms) - type, number and dimensional synthesis – precision points.	2 Hr
3.5	Graphical synthesis for motion - path and prescribed timing - function generator. 2 position and 3 position synthesis	2 Hr
3.6	Overlay Method. Freudenstein's equation	1 Hr
4	Module-4-	8 Hours
4.1	Static force analysis- Analysis of four bar linkages and slider crank mechanism	2 Hr
4.2	Graphical method, Matrix method	1 Hr
4.3	principle of virtual work	1 Hr
4.4	Analysis of four bar and slider crank mechanisms with sliding and pin friction.	1 Hr

4.4	Gyroscopic couples-spin, precession and applied gyroscopic couple vectors	2 Hr
4.5	Effects on the stability of two wheelers , Four wheelers, sea vessals and air crafts	1 Hr
5	Module-5- Kinematics-synthesis	8 Hours
5.1	Static balancing-dynamic balancing-	2 Hr
5.2	balancing of several masses in the same plane	1 Hr
5.3	several masses in different planes-graphical and analytical method	1 Hr
5.4	force and couple polygons	1 Hr
5.5	Balancing of reciprocating masses -Single cylinder engine	1 Hr
5.6	multi cylinder engine-v engine-inline engine	2 Hr

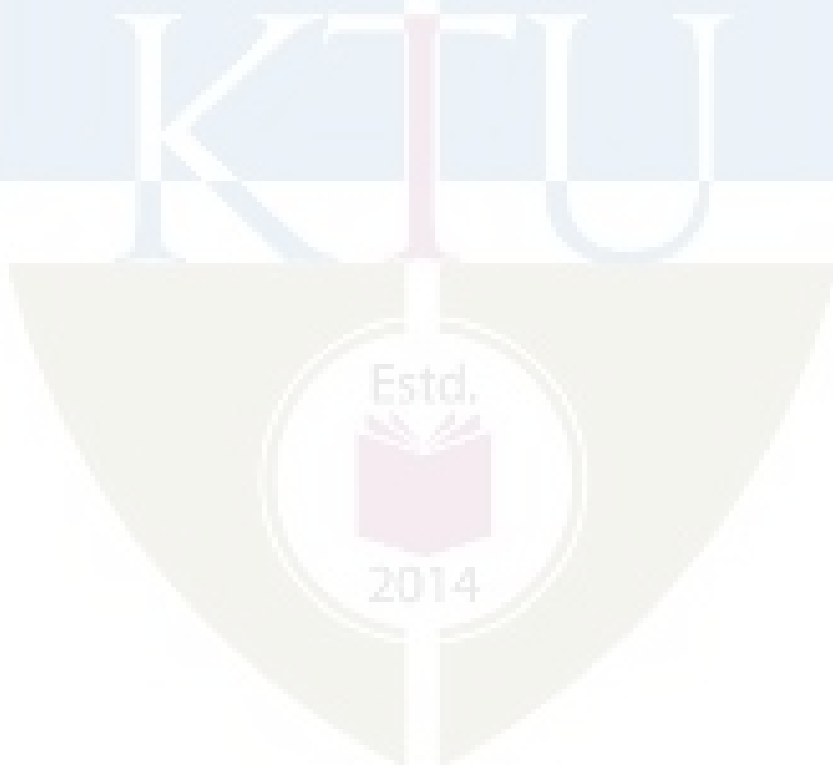

CODE MET303	COURSE NAME THERMAL ENGINEERING	CATEGORY	L	T	P	CREDIT
		PCC	3	1	0	4

Preamble: This course involve the application of principles studied in thermodynamics to different energy conversion systems like steam turbine, steam nozzle, steam powerplant, IC engines and refrigeration systems. This course also covers the methods for improving and evaluating the performance of different energy conversion systems. This course also helps to understand the combustion phenomenon in IC engines.

Prerequisite: MET202 Engineering Thermodynamics

Course Outcomes: After the completion of the course the student will be able to

CO 1	Explain the working of steam power cycle and related components
CO 2	Discuss the working of steam turbines and methods for evaluating the performance
CO 3	Illustrate the performance testing and evaluation of IC engines
CO 4	Explain the combustion phenomenon and pollution in IC engines
CO 5	Discuss the principles of refrigeration and air-conditioning and basic design considerations

Mapping of course outcomes with program outcomes

	PO 1	PO 2	PO 3	PO 4	PO 5	PO 6	PO 7	PO 8	PO 9	PO 10	PO 11	PO 12
CO 1	3	3	2									
CO 2	3	3	2									
CO 3	3	3	2									
CO 4	3	3	2									
CO 5	3	3	2									

Assessment Pattern

Bloom's Category	Continuous Assessment Tests		End Semester Examination
	1	2	
Remember	10	10	10
Understand	20	20	20
Apply	20	20	70
Analyse			
Evaluate			
Create			

Mark distribution

Total Marks	CIE	ESE	ESE Duration
150	50	100	3 hours

Continuous Internal Evaluation Pattern:

Attendance	: 10 marks
Continuous Assessment Test (2 numbers)	: 25 marks
Assignment/Quiz/Course project	: 15 marks

MECHANICAL ENGINEERING

End Semester Examination Pattern: There will be two parts; Part A and Part B. Part A contain 10 questions with 2 questions from each module, having 3 marks for each question. Students should answer all questions. Part B contains 2 questions from each module of which student should answer any one. Each question can have maximum 2 sub-divisions and carry 14 marks.

Course Level Assessment Questions

Course Outcome 1 (CO1):

1. In a reheat Rankine cycle, steam at a pressure of 40 bar and 300°C is expanded through a turbine to a pressure of 4 bar. It is then heated at a constant pressure to 300°C and then expanded to 0.1 bar. Estimate the work done per kg of steam flowing through the turbine, the amount of heat supplied during the reheat process and the cycle efficiency. Neglect pump work.
2. Dry saturated steam enters a frictionless adiabatic nozzle with negligible velocity at a temperature of 300 °C. It is then expanded to a pressure of 40 bar. For a mass flow rate of 2 kg/s, calculate the exit velocity of the steam.
3. With the help of a figure explain the working of Babcock and Wilcox boiler.

Course Outcome 2 (CO2):

1. In an impulse steam turbine, steam issues from the nozzle with a velocity of 1200 m/s. The nozzle angle is 20° and the mean blade velocity is 400 m/s. The inlet and outlet blade angles are equal. The blade velocity coefficient is 0.8. The mass of steam flowing through the turbine per hour is 950 kg. Calculate: (i) Blade angles. (ii) Relative velocity of steam entering the blades (iii) Tangential force on the blades. (iv) Power developed. (v) Blade efficiency.
2. In a reaction turbine, the mean blade speed is 150 m/s and the ratio of blade speed to steam speed is 0.625. The outlet angles of fixed and moving blades are 20° and 30° respectively. Calculate (i) the degree of reaction (ii) the adiabatic enthalpy drop in a pair of blade rings and (iii) the gross stage efficiency. The specific volume of steam at fixed blade outlet is 0.567 m³ and at moving blade outlet 0.6 m³. Assume the efficiency of blades when considered as nozzles 0.90 and $k^2 = 0.86$, where k is the blade velocity coefficient.
3. Derive the conditions for maximum efficiency of a Parsons reaction turbine.

4. Discuss the means of improving the performance of a steam turbine.

Course Outcome 3(CO3):

1. A 4-cylinder four stroke petrol engine is working based on the following data: Air-fuel ratio by weight = 15:1, calorific value of the fuel = 45000 kJ/kg, mechanical efficiency = 80 %, air- standard efficiency = 54 %, relative efficiency = 70 %, volumetric efficiency = 75 %, stroke/bore ratio = 1.25, suction conditions = 1 bar and 30 °C, r.p.m. = 2500, brake power = 70 kW. Calculate: (i) Compression ratio. (ii) Indicated thermal efficiency. (iii) Brake specific fuel consumption. (iv) Bore and stroke.
2. Discuss the working of a rotary engine and its merits and demerits over conventional IC engines.
3. How Morse test and retardation test helps to find the friction power of an engine?
4. Explain the procedure for heat balance test and its significance.

Course Outcome 4 (CO4):

1. Explain equivalence ratio and its significance in IC engine combustion.
2. Explain different stages of SI engine combustion with the help of pressure-crank angle diagram.
3. Discuss detonation in SI engine, cause and effects and the engine variable influencing the same.
4. Explain different pollution control methods employed for reducing the emissions in IC engines.

Course Outcome 5 (CO5):

1. Derive the expression for COP of an ideal air refrigeration cycle.
2. A food storage locker with R12 refrigerant requires a refrigeration of 2400 kJ/min. capacity has an evaporator temperature of 263 K and a condenser temperature of 303 K. The refrigerant is sub cooled by 6 °C before entering the expansion valve and vapour is superheated by 7 °C before leaving the evaporator coil. The refrigeration compressor is a two cylinder single acting with stroke equal to 1.25 times the bore and operates at 1000 rpm. Calculate i) Mass of refrigerant circulated/min. ii) Heat removed by condenser/min iii) Theoretical bore and stroke.
3. Sensible and latent loads on a space are 50 kW and 10 kW respectively. Cold and dehumidified air at 10 °C DBT and 90 % RH is used to maintain the space condition at 24 °C DBT. Find i) RSHF ii) space relative humidity and iii) mass flow rate of supply air?

MODEL QUESTION PAPER
APJ ABDUL KALAM TECHNOLOGICAL UNIVERSITY
V SEMESTER BTECH DEGREE EXAMINATION
MET303: THERMAL ENGINEERING

Maximum: 100 Marks

Duration: 3 hours

Use of Steam tables, Refrigeration tables, Charts and Psychrometric chart is permitted.

PART A

Answer all questions, each question carries 3 marks

1. Explain Rankine cycle with help of a T-S diagram.
2. Differentiate between fire tube boiler and water tube boiler.
3. List the difference between throttle governing and nozzle governing.
4. Explain degree of reaction of a steam turbine.
5. With the help of a diagram explain turbocharging.
6. Explain the procedure of Morse test.
7. Discuss about pollutants coming from a CI engine.
8. What do you mean by Octane number?
9. Why reversed Carnot cycle is practically impossible to execute?
10. Define bypass factor and mention its significance. (10×3=30 Marks)

PART B

Answer one full question from each module

MODULE 1

11. a) Steam at a pressure of 15 bar and 250 °C is expanded through a turbine to a pressure of 4 bar. It is then reheated at constant pressure to initial temperature of 250 °C and finally expanded to condenser pressure of 0.1 bar. Calculate efficiency of the cycle. What will be the efficiency if reheating is not employed? Pump work can be neglected. (8 marks)
- b) Derive the expression for mass flow rate of steam through a nozzle and obtain the critical pressure ratio. (6 marks)

12. a) With the help of a neat figure explain the working of a Benson boiler. What are its merits over other boilers? (8 marks)

b) With the help of T-s and p-h diagram explain the significance of binary vapour cycle. (6 marks)

MODULE 2

13. a) Derive the condition for maximum efficiency of a reaction turbine. (6 marks)

b) With the help of figures enumerate the difference between pressure compounding and velocity compounding of steam turbines. (8 marks)

14. a) What do you mean by reheat factor? List the parameters influencing the value of reheat factor. (4 marks)

b) In an impulse steam turbine, steam issues from the nozzle with a velocity of 1200 m/s. The nozzle angle is 20° and the mean blade velocity is 400 m/s. The inlet and outlet blade angles are equal. The blade velocity coefficient is 0.8. The mass of steam flowing through the turbine per hour is 950 kg. Calculate: (i) Blade angles. (ii) Relative velocity of steam entering the blades. (iii) Tangential force on the blades. (iv) Power developed. (v) Blade efficiency. (10 marks)

MODULE 3

15. a) With the help of a neat figure explain the working of Wankel engine. Mention its merits and demerits over conventional IC engines. (9 marks)

b) Discuss the effect of variable specific heat in actual cycle of IC engines. (5 marks)

16. a) The following observations were recorded during a trial of a four stroke single cylinder diesel engine for a trial duration of 30 min. Fuel consumption is 4 liters, Calorific value of fuel 43 MJ/kg, specific gravity of the fuel = 0.8, average area of indicator diagram = 8.5 cm^2 , length of indicator diagram = 8.5 cm, spring constant = 5.5 bar/cm, brake load = 150 kg, spring balance reading = 20 kg, effective brake wheel diameter = 1.5 m, speed = 200 rpm, cylinder diameter = 30 cm, stroke = 45 cm. Calculate i) indicated power ii) brake power iii) mechanical efficiency iv) specific fuel consumption in kg/kWh and v) indicated thermal efficiency. (10 marks)

b) Explain the concept of charge stratification in IC engines. (4 marks)

MODULE 4

MECHANICAL ENGINEERING

17. a) With the help of pressure-crank angle diagram explain different stages of CI engine combustion. (8 marks)

b) Explain the phenomenon of detonation in SI engine based on autoignition theory.

(6 marks)

18. a) With the help of figures compare different types of SI engine combustion chambers. (8 marks)

b) Discuss any two emission control methods employed in reducing the emission of CI engine. (6 marks)

MODULE 5

19. a) A freezer of 20 TR capacity has evaporator and condenser temperature of -30°C and 25°C respectively. The refrigerant R-12 is sub-cooled by 4°C before entering the expansion valve and is superheated by 5°C before entering the evaporator. If a six cylinder single acting compressor with stroke equal to bore running at 1000 rpm. is used. Determine i) COP ii) Theoretical piston displacement per minute iii) Theoretical bore and stroke. (9 marks)

b) Derive an expression for COP of a Reversed Brayton cycle for air refrigeration system. (5 marks)

20. a) 2.5 kg of air is cooled and dehumidified from 30°C DBT, 40% RH to 15°C DBT & 80% RH in a cooling and dehumidifying coil. Find (i) ADP, (ii) Bypass Factor and (iii) Heat Transfer. If bypass factor is halved keeping the ADP same find (iv) exit air condition and (v) Heat Transfer. (10 marks)

b) Define i) DPT ii) RH ii) SHF and iv) ADP. (4 marks)

Syllabus

MECHANICAL ENGINEERING

Module 1

Steam engineering- Rankine cycle, Modified Rankine cycle, Relative efficiency, Improvement in steam cycles-Reheat, Regenerative and Binary vapour cycle. Steam Boilers: Types of boilers, Cochran boiler, Babcock and Wilcox boiler, Benson boiler, La Mont boiler, Loeffler boiler, Velox boiler, Boiler Mountings and Accessories. Steam nozzles: -Types of nozzle, Velocity of steam, mass flow rate, critical pressure ratio and its significance, effect of friction, super saturated flow.

Module 2

Steam turbines: classification, compounding of turbines-pressure velocity variation, velocity diagrams, work done, efficiency, condition for maximum efficiency, multistage turbines-condition line, stage efficiency. Steam turbine performance-reheat factor, degree of reaction, cycles with reheating and regenerative heating, governing of turbines.

Module 3

Actual cycle analysis of IC engines- Deviation of actual engine cycle from ideal cycle, variable specific heats. Rotary engines, Stratified charge engine, Super charging and turbo charging. Performance Testing of I C Engines- Indicator diagram, mean effective pressure. Torque, Engine power- BHP, IHP. Engine efficiency, mechanical efficiency, volumetric efficiency, thermal efficiency, relative efficiency and Specific fuel consumption. Morse test, Heat balance test and Retardation test.

Module 4

Combustion in I.C. Engines- Analysis of fuel combustion-A/F ratio, equivalence ratio, excess air. Combustion phenomena in S.I. engines; Ignition limits, stages of combustion in S.I. Engines, Ignition lag, velocity of flame propagation, auto ignition, detonation; effects of engine variables on detonation; theories of detonation, octane rating of fuels; pre-ignition; S.I. engine combustion chambers. Combustion in C.I. Engines; delay period; variables affecting delay period; knock in C.I. engines, Cetane rating; C.I. engine combustion chambers. Air pollution from I.C. Engine and its control: Pollutants from S.I. and C.I. Engines, Methods of emission control.

Module 5

Refrigeration- Reversed Carnot cycle, Air refrigeration system- Reversed Joule cycle. Vapour compression systems-simple cycle - representation on T- s and P- h Diagrams. Effect of operating parameters on COP, Methods of improving COP of simple cycle, Super heating and under cooling. Psychometric properties – specific humidity, relative humidity and degree of saturation, thermodynamic equations, enthalpy of moisture, DBT, WBT and DPT, psychrometers, psychrometric chart. Psychometric processes- adiabatic mixing, sensible heating and cooling, humidifying and dehumidifying, air washer, bypass factor, sensible heat factor, Comfort and industrial air conditioning, Comfort air conditioning- factors affecting

human comfort, Effective temperature, comfort chart, Summer air conditioning, factors affecting, cooling load estimation.

Text Books

1. Rudramoorthy , Thermal Engineering, McGraw Hill Education India, 2003.
2. R.K Rajput, Thermal Engineering, Laxmi publications, 2010.
3. Arora C. P, Refrigeration and Air-Conditioning, McGraw-Hill, 2008.
4. Arora S. C. and Domkundwar, Refrigeration and Air-Conditioning, Dhanpat Rai, 2010.

Reference Books

1. V. Ganesan, Fundamentals of IC engines, Tata McGraw-Hill, 2002.
2. J.B.Heywood, I.C engine fundamentals. McGraw-Hill, 2011.
3. Rathore, Thermal Engineering, McGraw Hill Education India, 2010.
4. Dossat. R. J, Principles of Refrigeration, Pearson Education India, 2002.
5. Stoecker W.F, Refrigeration and Air-Conditioning, McGraw-Hill Publishing Company, 2009.

Course Contents and Lecture Schedule

No	Topic	No. of Lectures
1		
1.1	Steam engineering- Rankine cycle, Modified Rankine cycle, Relative efficiency, Improvement in steam cycles-Reheat, Regenerative and Binary vapor cycle.	4
1.2	Steam Boilers: Types of boilers, Cochran boiler, Babcock and Wilcox boiler, Benson boiler, , La Mont boiler, Loeffler boiler, Velox boiler, Boiler Mountings and Accessories.	3
1.3	Steam nozzles:-Types of nozzle- Velocity of steam, mass flow rate, critical pressure ratio and its significance, effect of friction, super saturated flow.	2
2		
2.1	Steam turbines: classification, compounding of turbines-pressure velocity variation, velocity diagrams.	3
2.2	Work done, efficiency, condition for maximum efficiency, multistage turbines-condition line, stage efficiency.	3
2.3	Steam turbine performance-reheat factor, degree of reaction, cycles with reheating and regenerative heating, governing of turbines.	3
3		

3.1	Actual cycle analysis of IC engines- Deviation of actual engine cycle from ideal cycle, variable specific heats.	2
3.2	Rotary engines, Stratified charge engine, Super charging and turbo charging.	2
3.3	Performance Testing of I C Engines- Indicator diagram, mean effective pressure. Torque, Engine power- BHP, IHP. Engine efficiency, mechanical efficiency, volumetric efficiency, thermal efficiency and relative efficiency, Specific fuel consumption.	3
3.4	Morse test, Heat balance test and Retardation test.	2
4		
4.1	Combustion in I.C. Engines- Analysis of fuel combustion-A/F ratio, equivalence ratio, excess air.	1
4.2	Combustion phenomena in S.I. engines; Ignition limits, stages of combustion in S.I. Engines, Ignition lag, velocity of flame propagation, auto ignition, detonation; effects of engine variables on detonation; theories of detonation, octane rating of fuels; pre-ignition; S.I. engine combustion chambers.	3
4.3	Combustion in C.I. Engines; delay period; variables affecting delay period; knock in C.I. engines, Cetane rating; C.I. engine combustion chambers.	3
4.4	Air pollution from I.C. Engine and its control: Pollutants from S.I. and C.I. Engines, Methods of emission control.	2
5		
5.1	Refrigeration– Reversed Carnot cycle, Air refrigeration system- Reversed Joule cycle.	2
5.2	Vapour compression systems-simple cycle - representation on T- s and P- h Diagrams. Effect of operating parameters on COP, Methods of improving COP of simple cycle, Super heating and under cooling.	2
5.3	Psychrometric properties – specific humidity, relative humidity and degree of saturation- thermodynamic equations- enthalpy of moisture- DBT, WBT and DPT–psychrometers, psychrometric chart.	1
5.4	Psychrometric processes- adiabatic mixing, sensible heating and cooling, humidifying and dehumidifying, air washer, bypass factor, sensible heat factor.	2
5.5	Comfort and industrial air conditioning, Comfort air conditioning- factors affecting human comfort, Effective temperature, comfort chart, Summer air conditioning, factors affecting, cooling load estimation.	2

MET305	INDUSTRIAL & SYSTEMS ENGINEERING	CATEGORY	L	T	P	CREDIT
		PCC	3	1	0	4

Preamble:

This course is designed to facilitate the students to acquire knowledge about management principles and practices of an industry. It empowers the students to amalgamate their knowledge of materials management, inventory management, lean manufacturing, agile manufacturing, industrial relations and enterprise resource planning and thus inculcate the skills needed to apply these principles in an industry.

Prerequisite: NIL

Course Outcomes: After the completion of the course the student will be able to

CO 1	Implement various tools and techniques in industrial engineering
CO 2	Calculate the inventory system for a given requirement
CO 3	Explain the importance of industrial relations
CO 4	Select the lean manufacturing tools to find and eliminate wastes
CO 5	Identify the framework of agile manufacturing
CO 6	Identify core and extended modules of enterprise resource planning

Mapping of course outcomes with program outcomes

	PO 1	PO 2	PO 3	PO 4	PO 5	PO 6	PO 7	PO 8	PO 9	PO 10	PO 11	PO 12
CO 1	2				2				2		2	2
CO 2	3			2						2	2	2
CO 3						1			2	2	1	2
CO 4	2	1		2	1						2	2
CO 5				2	1				2		2	2
CO 6	2				3						2	2

Assessment Pattern

Bloom's Category	Continuous Assessment Tests		End Semester Examination
	1	2	
Remember	10	10	20
Understand	20	40	60
Apply	20		20
Analyse			
Evaluate			
Create			

Mark distribution

Total Marks	CIE	ESE	ESE Duration
150	50	100	3 hours

Continuous Internal Evaluation Pattern:

Attendance	: 10 marks
Continuous Assessment Test (2 numbers)	: 25 marks
Assignment/Quiz/Course project	: 15 marks

End Semester Examination Pattern: There will be two parts; Part A and Part B. Part A contain 10 questions with 2 questions from each module, having 3 marks for each question. Students should answer all questions. Part B contains 2 questions from each module of which student should answer any one. Each question can have maximum 2 sub-divisions and carry 14 marks.

Course Level Assessment Questions**Course Outcome 1 (CO1):**

1. Calculate the breakeven point for the product.
2. What are the functions of Industrial Engineering?
3. What are the human factors to be considered while designing a new product?

Course Outcome 2 (CO2)

1. List various types of material handling equipments
2. Determine the optimum quantity to be ordered
3. Describe the role played by the materials management function in enabling an organisation to achieve profitability.

Course Outcome 3(CO3):

1. Define 'Job Satisfaction'.
2. Describe the causes of poor industrial relations.
3. What is meant by 'collective bargaining'?

Course Outcome 4 (CO4):

1. Compare the inventory levels in conventional and lean manufacturing systems.
2. Expand the Japanese terms of 5S
3. Describe the basic elements of lean manufacturing

Course Outcome 5 (CO5):

1. Describe the components of agile manufacturing system
2. List the measures that are used to measure innovation in agile production system.
3. How do strategic linkages aid the organisation to acquire agility?

Course Outcome 6 (CO6):

1. Enumerate ERP implementation stages.
2. With the aid of a block diagram, explain the construction and working of ERP framework.
3. Describe ERP related technology

Model Question paper

APJ ABDUL KALAM TECHNOLOGICAL UNIVERSITY

FIFTH SEMESTER B.TECH DEGREE EXAMINATION

MET305 INDUSTRIAL & SYSTEMS ENGINEERING

Max. Marks: 100

Duration: 3 Hours

PART A

Answer ALL questions, each carries 3 marks.

1. What are the human factors to be considered while designing a new product?
2. Describe the procedure followed while designing a product.
3. List various types of material handling equipments
4. Describe the concept of JIT manufacturing system
5. Describe the causes and effects of industrial disputes and how it can be eliminated
6. What are the methods of elimination of fatigue?
7. Expand the Japanese terms of 5S.
8. Describe the characteristics of agile manufacturing.
9. State the evolution of ERP.
10. What is Online Analytical Processing?

PART B

Module 1

11. a) How inventories are classified and costs associated by inventories? (5)

b) A manufacturer has to supply 10,000 units of product annually. The unit cost is Rs. 2 and it costs Rs.36 to place an order. The inventory carrying cost is estimated at 9% of average inventory investment. Determine 1. EOQ 2.Optimum number of orders to be placed per annum. 3. Minimum total cost of inventory (9)
- 12 a) What are the principles of good product design (10)

b) The fixed cost of producing a product in a company is Rs. 8,00,000. Variable cost per unit of the product is Rs. 30. Each unit of the product is going to be sold at a price of Rs. 180. Determine the breakeven point of this product. (4)

Module 2

MECHANICAL ENGINEERING

13. Describe the role played by the materials management function in enabling an organisation to achieve profitability. (14)

14. a) What is meant by quantity discount? (4)

b) A retailer procures batteries for quartz watches and sells them to watch repair shops. The price paid by the retailer varies on the basis of the quantities of batteries procured by him. The quantity and the price/unit pattern offered to him are given below:

Quantity (Q)	Price per one unit of battery
$0 \leq Q < 100$	Rs.20
$100 \leq Q < 200$	Rs.18
$200 \leq Q$	Rs.15

The monthly demand for the batteries is 600 units. The storage cost is 15% of unit cost of the battery and the cost of ordering is Rs.30 per order. Determine the optimum quantity to be ordered by the retailer so that the total cost of procurement is minimum. (10)

Module 3

15. (a) List any five objectives of Trade union. (5)

(b) Trace the history of Trade unionism. (9)

16 (a) Explain conditions to be met for maintaining good industrial relations. (7)

(b) Describe the causes of poor industrial relations. (7)

Module 4

17. (a) Enumerate the objectives and key principles of lean manufacturing paradigm. (7)

(b) Compare traditional and lean manufacturing paradigms. (7)

18. List and describe any ten components of agile manufacturing system. (14)

Module 5

19. Describe the key processes of “Customer Relationship Management”. (14)

- 20 a) With the aid of a block diagram, explain the construction and working of ERP framework. (7)
- (b) Explain the differences between 'Business Engineering' and 'Business Process Reengineering'. (7)

Syllabus

Module 1

Introduction to Industrial Engineering - Evolution of modern Concepts in Industrial Engineering - Functions of Industrial Engineering - Field of application of Industrial Engineering - Design function - Objectives of design- Development of designs- prototype, production and testing - Human factors in design - Principles of good product design- tolerance design- quality and cost considerations- product life cycle- standardization, simplification, diversification- concurrent engineering- comparison of production alternatives - Economic aspects- C-V-P analysis – simple problems.

Module 2

Introduction to materials management – objectives – Types of material handling equipments - principles of material handling –Material selection – value analysis – make or buy decisions- Purchasing and procedures. Basic inventory management - Inventory -Functions, Costs, Classifications - EOQ Models- Assumptions- Quantity discount model- Q system- P system- Reorder level - Simple problems- Concept of JIT manufacturing system.

Module 3

Industrial relations- Psychological attitudes to work and working conditions - fatigue- Methods of eliminating fatigue- Effect of Communication in Industry-Industrial safety-personal protective devices-, causes and effects of industrial disputes- Collective bargaining- Trade union - Workers participation in management.

Module 4

Principles of Lean Manufacturing(LM) – Basic elements of LM– Introduction to LM Tools- Concept of wastes in LM and their narration - stages of 5S and waste elimination - Conventional Manufacturing versus Lean Manufacturing - Need for LM. Agile manufacturing - Definition, business need, conceptual frame work, characteristics, and generic features - Approaches to enhance ability in manufacturing - Managing people in agile organization

Module 5

Introduction of enterprise resource planning (ERP)- Concept of Enterprise, ERP Overview - Integrated information system - Myths about ERP – Evolution of ERP- Benefits of ERP implementation - Success and failure factors of ERP implementation - Small, medium and large enterprise vendor solutions- ERP and related technology: Business intelligence (BI), E-Commerce and E-Business, Business Process Reengineering (BPR), Data warehousing, Data mining, Online Analytical Processing(OLAP), Product lifecycle management(PLC), Supply chain

Text Books

1. Martand T. Telsang, “Industrial Engineering & Production Management”, S. Chand and Company Limited, 2018.
2. M. Mahajan, “Industrial Engineering & Production Management”, Dhanpat Rai & Co. (P) Limited, 2015.
3. O. P. Khanna, “Industrial Engineering and Management”, Dhanpat Rai Publications, 2018.
4. James P. Womack, Daniel T. Jones and Daniel Roos, “The Machine That Changed the World”, Free Press, New York, 2007.
5. Alexis Leon, “ERP Demystified”, Tata McGraw Hill Education Private Limited, New Delhi, 2008.

Reference Books

1. Kjell Zandin and Harold Maynard, “Maynard's Industrial Engineering Handbook”, McGraw-Hill Education, 2001.
2. Philips E. Hicks, “Industrial Engineering and Management – A new perspective”, McGraw Hill International Editions, New York, 1994.
3. B. Kumar “Industrial Engineering and Management “, Khanna Publishers,2013.
4. S.R. Devadasan, V. Mohan Sivakumar, R. Muruges and PR Shalij, “Lean and Agile Manufacturing: Theoretical, Practical and Research Futurities” PHI Learning private Limited, New Delhi, 2012.
5. Ravi Shankar, “Industrial Engineering and Management”, Golgotia Publications Pvt Ltd, NewDelhi, 2009.

Course Contents and Lecture Schedule

No	Topic	No. of Lectures
1	Introduction to Industrial Engineering	
1.1	Evolution of modern Concepts in Industrial Engineering - Functions of Industrial Engineering - Field of application of Industrial Engineering	2
1.2	Design function - Objectives of design- Development of designs-prototype, production and testing - Human factors in design - Principles of good product design- tolerance design	2
1.3	Quality and cost considerations- product life cycle- standardization, simplification, diversification- concurrent engineering	2
1.4	Comparison of production alternatives - Economic aspects- C-V-P analysis – simple problems	2
2	Introduction to materials management	

2.1	Objectives – Types of material handling equipments	1
2.2	Principles of material handling –Material selection – value analysis	2
2.3	Make or buy decisions-Purchasing procedure	1
2.4	Inventory -Functions, Costs, Classifications	1
2.5	EOQ Models- Assumptions- Quantity discount model- Q system- P system- Reorder level - Simple problems, JIT	3
3	Industrial relations	
3.1	Psychological attitudes to work and working conditions	1
3.2	Fatigue- Methods of eliminating fatigue	1
3.3	Effect of Communication in Industry-Industrial safety-personal protective devices	2
3.3	Causes and effects of industrial disputes- Collective bargaining	2
3.4	Trade union - Workers participation in management	1
4	Lean Manufacturing and Agile manufacturing	
4.1	Principles of Lean Manufacturing(LM) – Basic elements of LM– Introduction to LM Tools	2
4.2	Concept of wastes in LM and their narration	1
4.3	Stages of 5S and waste elimination	2
4.4	Conventional Manufacturing versus Lean Manufacturing - Need for LM.	1
4.5	Agile manufacturing – Definition , business need	1
4.6	Agile manufacturing - conceptual frame work, characteristics, and generic features	2
4.7	Approaches to enhance ability in manufacturing -	1
4.8	Managing people in agile organization	1
5	Introduction of Enterprise Resource Planning	
5.1	Introduction of enterprise resource planning (ERP)- Concept of Enterprise, ERP Overview - Integrated information system - Myths about ERP – Evolution of ERP	2
5.2	Myths about ERP - Basic ERP concepts - Small, medium and large enterprise vendor solutions	2
5.3	Benefits of ERP implementation, Success and failure factors of ERP implementation	1
5.4	Business intelligence (BI), E-Commerce and E-Business, Business Process Reengineering (BPR)	2
5.5	Data warehousing, Data mining, Online Analytical Processing(OLAP), Product lifecycle management(PLC)	2
5.6	Supply chain management(SCM), Customer relationship management (CRM)	1
5.7	ERP implementation challenges, Emerging trends on ERP	1

MET 307	MACHINE TOOLS AND METROLOGY	CATEGORY	L	T	P	Credits
		PCC	3	1	0	4

Preamble:

To develop knowledge of appropriate process parameters to be used for various machining operations.

Understand the fundamentals of modern quality concepts. Be able to apply statistical techniques.

Understand the principles and operation of precision measurement tools and equipment used in modern manufacturing.

Prerequisite: MET 205 Metallurgy and Material Science and PHT 110 Engineering Physics

Course Outcomes - At the end of the course students will be able to

CO 1	Analyze various machining process and calculate relevant quantities such as velocities, forces and powers.
CO 2	Analyze of the tool nomenclature with surface roughness obtainable in each machining processes.
CO 3	Understand the limitations of various machining process with regard to shape formation and surface texture.
CO 4	Demonstrate knowledge of the underlying principles of measurement, as they relate to mechanical measurement, electronic instrumentation, and thermal effects.
CO 5	Get an exposure to advanced measuring devices and machine tool metrology.

Mapping of course outcomes with program outcomes (Minimum requirements)

	PO 1	PO 2	PO 3	PO 4	PO 5	PO 6	PO 7	PO 8	PO 9	PO 10	PO 11	PO 12
CO 1	2	3	-	-	-	-	-	-	-	-	2	1
CO 2	2	3	-	-	-	-	-	-	-	-	2	1
CO 3	2	1	-	2	2	-	-	-	-	-	-	2
CO 4	3	-	2	-	-	-	-	-	-	-	2	2
CO 5	2	-	-	2	3	-	-	-	-	-	-	3

ASSESSMENT PATTERN

Bloom's taxonomy	Continuous Assessment Tests		End Semester Examination (Marks)
	Test 1 (Marks)	Test 11 (Marks)	
Remember	25	25	25
Understand	15	15	15
Apply	30	25	30
Analyze	10	10	10
Evaluate	10	15	10
Create	10	10	10

Mark distribution			
Total Marks	CIE marks	ESE marks	ESE duration
150	50	100	3 Hours
Continuous Internal Evaluation (CIE) Pattern:			
Attendance		10 marks	
Regular class work/tutorials/assignments/self learning (Minimum 3 numbers)		15 marks	
Continuous Assessment Test(Minimum 2numbers)		25 marks	
<p>End semester pattern:-There will be two parts; Part A and Part B. Part A contain 10 questions with 2 questions from each module, having 3 marks for each question. Students should answer all questions. Part B contains 2 questions from each module of which student should answer anyone. Each question can have maximum 2 sub-divisions and carry 14 marks.</p>			
COURSE LEVEL ASSESSMENT QUESTIONS			
<p>Course Outcome 1 (CO1) Analyze various machining process and calculate relevant quantities such us velocities, forces and powers.</p> <ol style="list-style-type: none"> List out various types of Lathe attachment explain Explain the working principle of slotter In a vernier calliper, the main scale reads in millimetres with a least count of 0.1 mm.Ten divisions on the vernier correspond to nine divisions of the main scale. Determine the 			

leastcount of the calliper.

4. A shaft is manufactured within the specified limits of 30.02 and 29.98 mm. Find the high and low limits of the bush to give a maximum clearance of 0.10 mm and minimum clearance of 0.02 mm.
5. What is the difference between rough grinding and precision grinding?

Course Outcome 2 (CO2): Analysis of the tool nomenclature with surface roughness obtainable in each machining processes.

1. Define the terms 'Cutting speed', 'feed' and 'depth of cut'?
2. How are abrasives selected for grinding operation?
3. Why a coolant used in grinding work?
4. How the grinding wheel is selected for a particular job?
5. Describe the nomenclature of hob.
6. Discuss the significant machining parameters for shaping machine.

Course Outcome 3 (CO3): Understand the limitations of various machining process with regard to shape formation and surface texture.

1. What is the difference between drilling, boring and reaming?
2. Explain any three thread production processes.
3. Explain counter sinking and trepanning.
4. Explain different types of gear hobbing machines.
5. Explain planning of guide gibs and slotting of keyways.

Course Outcome 4 (CO4): Students will demonstrate knowledge of the underlying principles of measurement, as they relate to mechanical measurement, electronic instrumentation, and thermal effects.

1. Describe the GO and NOGO gauge design procedure with neat sketch.
2. **Design general type GO and NO GO gauges for a 40H7/d8 fit. 40 mm lies in the diameter range 30 to 50. Show graphically the disposition of gauge tolerance zones relative to the work tolerance zones. Standard tolerance for IT7 is 16i and IT8 is 25i, where 'T' is the standard tolerance unit. The upper deviation for 'd' shaft is $-16D^{0.44}$.**
3. A 50 mm long pin having diameter 20 ± 0.02 mm, will be electroplated for a thickness of 50 ± 5 μ m. Estimate the size of a GO limit gauge, neglecting the gauge to tolerances.

Course Outcome 5 (CO5): Get an exposure to advanced measuring devices and machine tool metrology.

1. Is assessment length greater/lesser than transverse length in surface roughness measurements? Why?
2. A surface tested under an optical flat using interferometer shows the following interference fringe pattern. Interpret the nature of the surface.

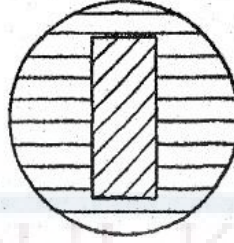

3. What are difference between Rt and Rz with neat sketches
4. How are CMM classified based on their construction? With neat sketches explain the merits and applications any one of them.

MODEL QUESTION PAPER

FIFTH SEMESTER MECHANICAL ENGINEERING

MACHINE TOOLS AND METROLOGY-MET 307

Max. Marks: 100 Duration: 3 Hours

Part – A

Answer all questions.

Answer all questions, each question carries 3 marks

1. What is trepanning? Explain with sketch.
2. What are the use of face plate and angle plate in a lathe?
3. With a sketch, show rake angle of milling cutter and chip breaker.
4. What s the difference between grinding wheel dressing and truing
5. What is the principle of Gear shaping? Explain.
6. Write note on gear errors.
7. Differentiate between precision and accuracy.
8. Explain the process of wringing of slip gauges.
9. Write the importance of cut off length in surface roughness measurement
10. Explain the principle of measurement by light wave interference method.

PART –B

Answer one full question from each module.

MODULE – 1

11. a.What are the attachments used on a center lathe and what purpose do they serve? (7 marks).

b.Draw a drillsignature, name the important angles and explain their each functionand explain plaining of guide gibs(7 marks).

12. Draw sketch of a crank shaper, mark the important parts and explain their functions. Explain how quick return mechanism works. (14 marks).

MODULE – 2

13. a. Explain the principle of working of centreless grinding machine. (7 marks).
b. What are 'Through Feed', 'In Feed', and 'End Feed' in centreless grinding operations? (7 marks).
14. a. Explain in detail with neat sketches of a) Slot and groove milling, b) profile milling c) thread milling(7 marks).
b. What is the need of better surface finish and how honing, lapping and burnishing process are different in its features and roughness obtainable, explain with sketches. (7 marks).

MODULE – 3

15. Why gear finishing processes are required? Write down the advantages and limitations of gear shaving and gear lapping process with neat sketches. (14 marks).
- 16 Describe the different methods of manufacturing various types of gears i. Preforming
ii. Producing gear teeth by machining iii. Finishing gear teeth (14 marks).

MODULE – 4

- 17 Discuss all the principles of achieving accuracy. Explain all types of errors. (14 marks).
18. Determine limit dimensions for a clearance fit between mating parts of diameter 40 mm, providing a minimum clearance of 0.10 mm with a tolerance on the hole equal to 0.025mm and on shaft 0.05mm using both systems(14 marks).

MODULE – 5

- 19 a) Define the following terms in surface texture measurements: -
(i) Primary Texture.(ii) Secondary Texture.(iii) Lay(iv) Sampling Length.(7 marks).
b) Describe the method of evaluating roughness using(i) Peak to valley high method.
(ii) C.L.A. method. (7 marks).
- 20 a) Discuss the different types of probes used in CMM (7 marks).
b.) Explain the various steps in machine vision system (7 marks).

SYLLABUS**MODULE – 1**

General purpose machine tools – types and classification of machine tools –types and classification of lathe – methods of holding work and tool –lathe accessories and attachments –lathe operations -tool room lathe – duplicate lathe –capstan and turret lathe –horizontal and vertical-single spindle and multi spindle screw machines - Shaping, Planing and Slotting machines – Work holding devices-types of operations - surface roughness obtainable indexing - Drilling and boring Machines – -Drill bit nomenclature- cutting forces in drilling – tool and work holding devices-boring tools and reamers.

MODULE – II

Milling tool nomenclature - Cutting forces in milling – Calculation of machining time- Indexing head Different indexing methods -Grinding, honing and lapping – types of grinding machines-operations: cutting forces in grinding -Grinding mechanisms – Grinding wheels - surface roughness obtainable in grinding, honing and lapping.

MODULE – III

Broaching machines –different machines – cutter for broaching – broaching processes – internal external broaching - Gear cutting –methods in gear production – form cutters –gear generating machines – gear hobbing machines – gear broaching -Bevel gear cutting –worm gear cutting –gear finishing.

MODULE – IV

Metrology –principles of achieving accuracy -Theory of tolerances and allowances –system of limits and fits – types of fits – interchangeability and selective assembly –standards of measurements- Gauges – classification of gauges –principle of gauge tolerance –wear allowance.

MODULE – V

Instruments for checking straightness, flatness and squareness–pneumatic gauging –precision gauging – automatic gauging for inspection-Optical measuring instruments –Comparators –Measurements of surface roughness – gauging and measurements of screw and gears- Advanced measuring devices – Laser interferometers- Coordinate Measuring Machine (CMM).

Text Books

1. Chapman W. A. J., Workshop Technology, Viva books (P) Ltd
2. HMT, Production Technology, Tata McGraw-Hill
3. Engineering Metrology and Measurements, N.V. Raghavendra, I. Krishnamurthy, Oxford university press
4. Galyer J.F.W., Schotbolt C.R., Metrology for Engineers, ELBS.

Reference

1. Acharkan. N., Machine Tool Design Vol. 1 to 4, MIR Publication
2. Chernov, Machine Tools, MIR Publication.
3. HajraChoudary, Elements of workshop technology, Vol I & II, Media Publishers.
4. ASME, Hand book of Industrial Metrology.
5. Hume K. J., Engineering Metrology, Macdonald &Co. Ltd.
6. Sharp K.W.B., Practical Engineering Metrology, Sir Isaac Pitman & Sons Ltd.

COURSE CONTENT AND LECTURE SCHEDULES.

Module	TOPIC	No.of hours	Course outcomes
1.1	General purpose machine tools – types and classification of machine tools –Lathe – types and classification of lathe – specification for a lathe –	1	CO3
	Feed,depth of cut, speed-methods of holding work and tool – lathe accessories and attachments –lathe operations and tools used for each operations -	3	CO1
1.2	Brief study of the machine and the nature and type of jobs handled by the following: - tool room lathe – duplicate lathe – capstan and turret lathe –horizontal and vertical-single spindle and multi spindle screw machines.	3	CO2
1.3	Shaping, Planing and Slotting machines – Types and specifications – quick return motion –hydraulic feed and its advantages - automatic feed – speed,feed and depth of cut– Work holding devices-types of operations and examples of work done- surface roughness obtainable indexing (Self learning portion, discretion of faculty, fundamentals to be explained in the class)	1	CO3
1.4	Drilling and boring Machines – Types and specifications – Brief descriptions about the machines and nature, types of job	1	CO3

	handled by each of them.		
1.5	-Drill bit nomenclature- cutting forces in drilling – tool and work holding devices-boring tools and reamers.	1	CO2
2.1	Milling machines – types and specifications- Milling operations and types of milling cutters used for each.	1	CO3
2.2	- Milling tool nomenclature - Cutting forces in milling – Calculation of machining time- Indexing head and its use -	1	CO1 CO3
2.3	Different indexing methods - Differential indexing (Self learning portion discretion of faculty, fundamentals to be explained in the class)	1	
2.4	Grinding, honing and lapping – types of grinding machines-operations: cylindrical, surface and center less grinding – internal grinding, tool and cutter grinding - cutting forces in grinding	3	CO1 CO3
2.5	Grinding mechanisms – Grinding wheels: Specification – types of abrasives, grain size -Types of bond, grade, and structure – Marking system of grinding wheels – Selection of grinding wheels –need of better surface finish; surface roughness obtainable in grinding, honing, lapping and burnishing; Surface roughness comparisons between different conventional metal cutting processes.	3	CO3
3.1	Broaching machines –different machines – cutter for broaching – different broaching processes – internal external broaching.	3	CO3
3.2	Gear cutting –methods used in gear production – form cutters – gear generating machines – gear hobbing machines – gear broaching.	3	CO3
3.3	Bevel gear cutting – straight and spiral gears-worm gear cutting –gear finishing operations.	3	CO3
4.1	Metrology –principles of achieving accuracy –economic machining accuracy – precision Vs accuracy - errors- standards of measurements-	2	CO 4
4.2	Theory of tolerances and allowances –system of limits and fits – types of fits – interchangeability and selective assembly – Taylor’s Principle-	4	CO 4
4.3	Gauges – classification of gauges- plug, ring, taper angle, slip and snap gauges –feeler gauges-dial indicator –principle of gauge tolerance –wear allowance-gauge materials.	4	CO 4 CO 5
5.1	Instruments for checking straightness, angle, flatness and squareness of guiding surface(Self learning portion, discretion of faculty, fundamentals to be explained in the class). – pneumatic gauging –precision gauging –automatic gauging for inspection.	2	CO 4 CO 5

5.2	Optical measuring instruments, basic principle – interferometer-optical flat –optical tool makers’ microscope-autocollimator.	2	CO 5
5.3	Comparators – mechanical, optical, pneumatic, electric and electronic comparators. (Self learning portion, discretion of faculty, fundamentals to be explained in the class).	1	CO 4
5.4	Measurements of surface roughness – elements of roughness – symbols specifying –instruments and for measuring surface roughness-	1	CO 4
	Measurements of screw: terminology, measurement of screw thread elements-measurement of gears: terminology, errors in spur gears, measurement of gear elements.	2	
5.5	Advanced measuring devices – Laser interferometers-Coordinate Measuring Machine (CMM)	1	CO 5

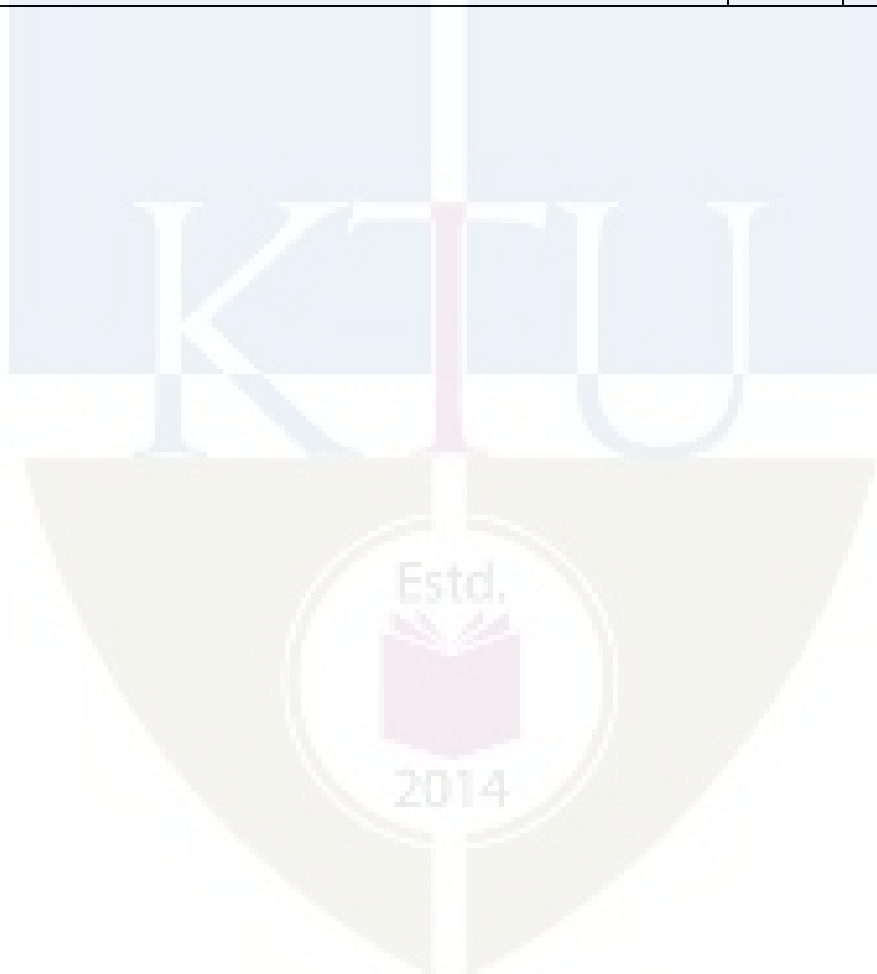

CODE MEL331	COURSE NAME: MACHINE TOOLS LAB II	CATEGORY	L	T	P	CREDIT
		PCC	0	0	3	2

Preamble:

1. To learn the measurement of bores by internal micrometers, bore indicators, indirect methods etc.
2. To learn the measurement of the Angle and taper by Bevel protractor, Sine bars, indirect methods etc.
3. Allow to study the various limits, fits and tolerances adopted in the production drawings.
4. To learn to measure straightness, flatness, roundness, profile, screw threads and gear teeth.
5. To learn, to prepare programs for CNC machines and measurements in CMM.

Course Outcomes - At the end of the course students will be able to

CO 1

Apply the procedures to measure length, angles, width, depth, bore diameters, internal and external tapers, tool angles, and surface roughness by using different instruments and by different indirect methods.

CO 2

Determine limits and fits and allocate tolerances for machine components

CO 3

CNC programming and to use coordinate measuring machine to record measurements of complex profiles with high sensitivity.

CO 4

Use effective methods of measuring straightness, Squareness, flatness, roundness, profile, screw threads and gear teeth.

CO 5

Securing knowledge of manufacturing components within the tolerance limit and surface roughness according to given drawings using various machine tools.

Mapping of course outcomes with program outcomes (Minimum requirements)

	PO 1	PO 2	PO 3	PO 4	PO 5	PO 6	PO 7	PO 8	PO 9	PO 10	PO 11	PO 12
CO 1	3	-	-	-	-	-	-	-	-	-	-	-
CO 2	-	-	3	-	-	-	-	-	-	-	-	-
CO 3	-	-	-	3	-	-	-	-	-	-	-	-
CO 4	-	3	-	-	-	-	-	-	-	-	-	-
CO 5	-	-	-	-	3	-	-	-	-	-	-	-

Assessment Pattern**Mark distribution**

Total Marks	CIE	ESE	ESE Duration
150	75	75	2.5 hours

Continuous Internal Evaluation Pattern:

Attendance	:	15 marks
Continuous Assessment	:	30 marks
Internal Test (Immediately before the second series test)	:	30 marks

End Semester Examination Pattern: The following guidelines should be followed regarding award of marks

(a) Preliminary work	:	15 Marks
(b) Implementing the work/Conducting the experiment	:	10 Marks
(c) Performance, result and inference (usage of equipments and trouble shooting)	:	25 Marks
(d) Viva voce	:	20 marks
(e) Record	:	5 Marks

General instructions:

Practical examination is to be conducted immediately after the second series test covering entire syllabus given below. Evaluation is a serious process that is to be conducted under the equal responsibility of both the internal and external examiners. The number of candidates evaluated per day should not exceed 20. Students shall be allowed for the University examination only on submitting the duly certified record. The external examiner shall endorse the record.

SYLLABUS

Experiments on Grinding machine – Programming and experiments on CNC machines-
 Uncertainty in metrology and measurement standards - Errors and their impact on the calculation of uncertainties - Measurement types and instrument selection - Geometric features of parts -
 Measuring straightness, squareness, flatness, roundness, and profile -Screw threads and gear teeth, optical contour projectors - Gage measurement - Surface texture and roughness measurement – flaw detection - Coordinate measuring machine - Modern measuring instruments and machines.

Reference books

1. Yoram Koren, Numerical Control of Machine Tools, McGraw-Hill.
2. Shotbolt C.R. and Gayler J.F.W, Metrology for Engineers, 5th edition, ELBS, London.
3. Sharp K.W.B. and Hume, Practical Engineering Metrology, Sir Isaac Pitman and sons Ltd,

London.

4. Collett, C.V. and Hope, A.D, Engineering Measurements, Second edition, ELBS/Longman

Experiments	List of Experiments	Course outcomes	No. of hours
1	Programming and experiment on CNC machines Study and preparation of programme, simulation and exercise on CNC lathe:-turning, step turning, taper turning, thread cutting, ball and cup turning etc.	CO 3	3
2	Study and preparation of programme, simulation and exercise on CNC milling machine: - surface milling, pocket milling, contour milling etc.		3
3	Experiment on Grinding machine Exercise on surface grinding, cylindrical grinding and tool grinding etc.	CO 1 CO 5	3
	Measurement of cutting forces and roughness in grinding process and correlate with varying input parameters.		
4	Basics for mechanical measurements Calibration of vernier caliper, micrometer and dial gauge. Determination of dimensions of given specimen using vernier caliper, micrometer, height gauge, bore dial gauge etc.	CO 1 CO 2	3
	Experiments on Limits, Fits and Tolerance Determine the class of fits between given shaft and hole. etc		
5	Experiments on Repeatability and Reproducibility Study and analysis of repeatability and reproducibility of given batch of steel balls. etc.	CO 1 CO 2	3
6	Linear measurements Study of different linear measuring instruments etc. Calibration of LVDT using slip gauges	CO 1 CO 5	3

7	<p>Straightness error measurement</p> <p>Study of different straightness error measuring instruments – basic principle of auto collimator, spirit level and laser interferometer.</p> <p>Measurement of straightness error of a CI surface plate using auto collimator and comparing with spirit level.</p> <p>Laser interferometer used to determine straightness error</p> <p>To check straightness error of a straight edge by the wedge method using slip gauges.</p>	CO 4	3
8	<p>Angle measurements</p> <p>Angular measurements using bevel protractor, combination sets, clinometers, angle dekkor etc.</p> <p>Measurement of angle and width of a V-block and comparing with combination sets.</p> <p>Measurement of angle using sine bar of different samples.</p> <p>Determination of angle and taper of a taper plug gauge</p>	CO 1	3
9	<p>Out of roundness measurement</p> <p>Study of different methods used for measuring out of roundness</p> <p>Measurement of out of roundness using form measuring instrument</p> <p>Measurement of out of roundness using V-block and dial gauge</p> <p>Measurement of out of roundness using bench centre and dial gauge etc.</p>	CO 4	3
10	<p>Screw thread measurement</p> <p>Measurement of screw thread parameters using two wire and three wire method.</p> <p>Measurement of screw thread parameters using tool maker's microscope etc.</p> <p>Measurement of screw thread parameters using thread ring gage, thread plug gage, thread snap gage, screw thread micrometer, optical comparator etc.</p>	CO 4	3
11	<p>Bore measurement</p> <p>Measurement of a bore by two ball method.</p> <p>Measurement of a bore by four ball method.</p> <p>Bore measurement using slip gauges and rollers.</p>	CO 1	3

	Bore measurement using bore dial gauge etc.		
12	<p>Gear metrology</p> <p>Study of types of gears – gear terminology – gear errors - Profile Projector.</p> <p>Measurement of profile error and gear parameters using profile projector etc.</p> <p>Use of Comparators</p> <p>Exercise on comparators: mechanical, optical, pneumatic and electronic comparators.</p>	CO 4	3
13	<p>Use of Tool maker's microscope</p> <p>Study of tool maker's microscope – use at shop floor applications.</p> <p>Measurement of gear tooth parameters using tool maker's microscope.</p> <p>Measurement of different angles of single point cutting tool using tool maker's microscope.</p>	CO 1	3
14	<p>Surface roughness measurement</p> <p>Measurement of surface roughness using surface profilometer /roughness measuring machine of turned, milled, grounded, lapped and glass etc specimens.</p>	CO 1	3
15	<p>Squareness measurement</p> <p>Determination of squareness of a trisquare using angle plate and slip gauges etc.</p>	CO 1	3
16	<p>Flatness measurement</p> <p>Study of optical flat and variation of fringe patterns for different surfaces.</p> <p>Determination of parallelism error between micrometer faces etc.</p> <p>Compare given surface using optical flat with interpretation chart.</p>	CO 4	3
17	<p>Vibration measurement</p> <p>Measurement of displacement, velocity and acceleration of vibration.</p>	CO 5	3

18	Use of Pneumatic comparator Checking the limits of dimensional tolerances using pneumatic comparator Calibration using air plug gauge etc	CO 5	3
19	Rotation measurement Determination of rpm using tachometer, optical tachometer and stroboscope, etc. Flaw detection Study and use of ultrasonic flaw detector.	CO 5	3
20	Other measurements Study and making measurements with precision vernier calipers, dial calipers, point micrometer spline micrometer, wire groove micrometer, depth micrometer, V- anvil micrometers, depth gear tooth micrometer, thread micrometer, disc micrometer, thread pitch gauge, vernier height gauge, feeler gauge, three pin micrometer, depth gauge, pitch gauge, thickness gauge, radius gauge, hole test etc. Analysis of automobile exhaust gas and flue gas. Use of feeler gauge to determine the gap of spark plug. Any other modern measuring instruments CMM, EDM, Wire cut EDM,USM etc	CO 5	3
<p>A minimum of 12 sets of experiments are mandatory out of total 20 experiments but both experiments mentioned for programming and experiments on CNC machines are mandatory.</p> <p>Besides to the skill development in performing the work, oral examination should be conducted during end semester examination.</p> <p>The student's assessment, continuous evaluation, record bonafides, awarding of sessional marks, oral examination etc. should be carried out by the assistant professor or above.</p>			

CODE MEL333	COURSE NAME: THERMAL ENGINEERING LAB 1	CATEGORY PCC	L 0	T 0	P 3	CREDIT 2
-----------------------	--	------------------------	---------------	---------------	---------------	--------------------

Preamble: The course is intended to impart basic understanding on the working of internal combustion engines. This includes various performance tests on internal combustion engines as well as makes the students familiar with the evaluation of fuel properties such as viscosity, flash and fire points, calorific value etc. which are key to any performance test.

Prerequisite: Should have undergone a course on Thermal Engineering with emphasis on IC engines

Course Outcomes: After completion of the course the student will be able to

CO 1	Measure thermo-physical properties of solid, liquid and gaseous fuels
CO 2	Identify various systems and subsystems of Diesel and petrol engines
CO 3	Analyse the performance characteristics of internal combustion engines
CO 4	Investigate the emission characteristics of exhaust gases from IC Engines
CO 5	Interpret the performance characteristics of air compressors / blowers

Mapping of course outcomes with program outcomes

	PO 1	PO 2	PO 3	PO 4	PO 5	PO 6	PO 7	PO 8	PO 9	PO 10	PO 11	PO 12
CO 1	3		2	3			2		3	2		2
CO 2	3		2	3			2		3	2		2
CO 3	3		2	3			2		3	2		2
CO 4	3		2	3			2		3	2		2
CO 5	3		2	3			2		3	2		2

Assessment Pattern

Mark distribution

Total Marks	CIE	ESE	ESE Duration
150	75	75	2.5 hours

Continuous Internal Evaluation Pattern:

Attendance	:	15 marks
Continuous Assessment	:	30 marks
Internal Test (Immediately before the second series test)	:	30 marks

End Semester Examination Pattern: The following guidelines should be followed regarding award of marks

- | | |
|--|------------|
| (a) Preliminary work | : 15 Marks |
| (b) Implementing the work/Conducting the experiment | : 10 Marks |
| (c) Performance, result and inference (usage of equipments and trouble shooting) | : 25 Marks |
| (d) Viva voce | : 20 marks |
| (e) Record | : 5 Marks |

General instructions:

Practical examination is to be conducted immediately after the second series test covering entire syllabus given below. Evaluation is a serious process that is to be conducted under the equal responsibility of both the internal and external examiners. The number of candidates evaluated per day should not exceed 20. Students shall be allowed for the University examination only on submitting the duly certified record. The external examiner shall endorse the record.

List of Exercises/Experiments: (Lab experiments may be given considering 12 sessions of 3 hours each. Minimum 12 experiments to be performed.)

1. Determination of flash and fire points of petroleum fuels and oils
2. Determination of viscosity of lubricating oils and fuels and its variation with temperature
3. Determination of calorific value of solid and liquid fuels- Bomb Calorimeter
4. Determination of calorific value of gaseous fuels –Gas Calorimeter
5. Familiarisation of various systems and subsystems of petrol engine / MPFI engine
6. Familiarisation of various systems and parts of Diesel engine / Turbocharged engine
7. Performance test on petrol engines / MPFI engine
8. Performance test on Diesel engines / Turbocharged engine
9. Heat Balance test on petrol/Diesel engines
10. Determination volumetric efficiency and Air-fuel ratio of IC engines
11. Cooling curve of IC engines
12. Valve timing diagram of IC engines
13. Economic speed test on IC engines
14. Retardation test on IC engines
15. Morse test on petrol engine
16. Experiment to find flame temperature of premixed flames at different equivalence ratios and temperature of diffusion flames at different fuel flow rates.
17. Analysis of automobile exhaust gas and flue gas using exhaust gas analyser.
18. Performance test on reciprocating compressor
19. Performance test on rotary compressor/blower

Reference Books

1. J.B.Heywood, I.C engine fundamentals, McGraw-Hill, 2017
2. V. Ganesan, Fundamentals of IC engines, Tata McGraw-Hill, 2017
3. Stephen R Turns, An Introduction to Combustion: Concepts and Applications, McGraw-Hill, 2017

APJ ABDUL KALAM
TECHNOLOGICAL
UNIVERSITY

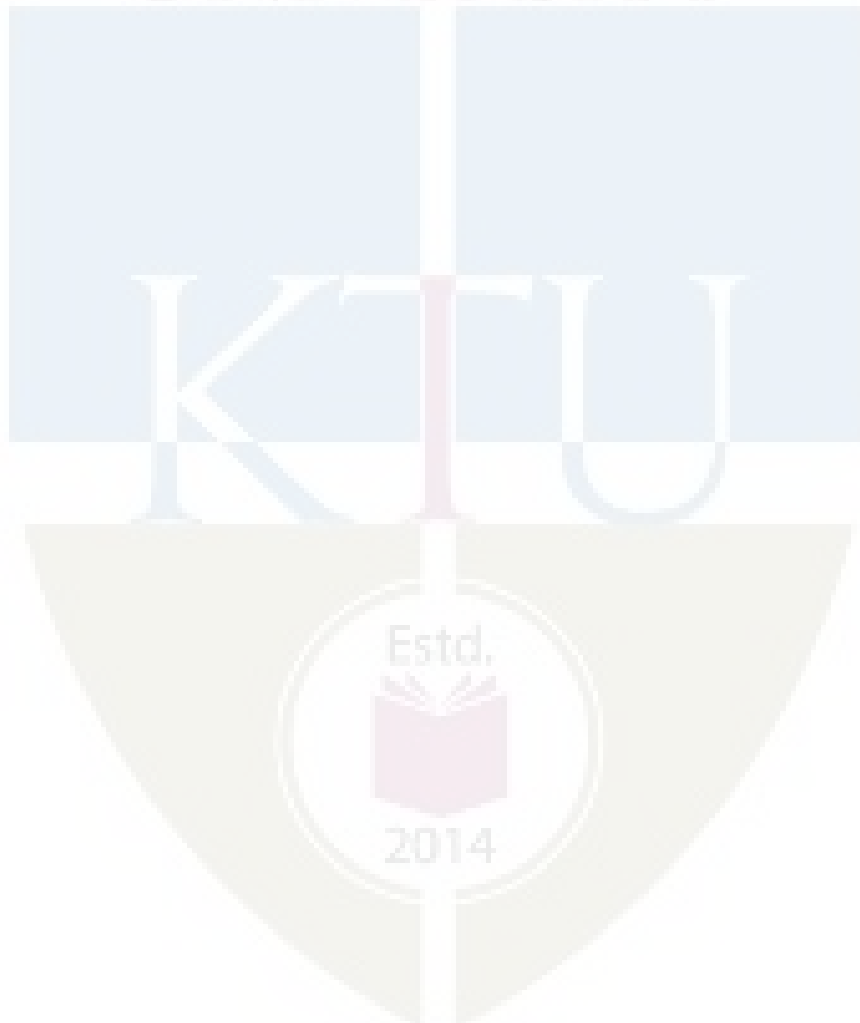

APJ ABDUL KALAM
TECHNOLOGICAL
UNIVERSITY

SEMESTER V

MINOR



CODE MET381	Course Name DYNAMICS OF MACHINES	CATEGORY VAC	L 3	T 1	P 0	CREDIT 4
-----------------------	--	------------------------	---------------	---------------	---------------	--------------------

Preamble: This course mainly covers the topics namely force analysis of engines, turning moment diagrams, balancing of rotating and reciprocating machines and stability analysis of vehicles. Analysis of free and forced vibration of single degree of freedom systems are included.

Prerequisite: EST100 Engineering Mechanics

Course Outcomes: After the completion of the course the student will be able to:

CO 1	Analyse forces in a four bar mechanism
CO 2	Draw turning moment diagrams for a steam engines and internal combustion engines.
CO 3	Calculate the unbalanced masses in rotating and reciprocating machines.
CO 4	Calculate gyroscopic couple and do stability analysis of vehicles
CO 5	Analyse free and forced vibrations of single degree of freedom systems

Mapping of course outcomes with program outcomes

	PO 1	PO 2	PO 3	PO 4	PO 5	PO 6	PO 7	PO 8	PO 9	PO 10	PO 11	PO 12
CO 1	3	3	2									
CO 2	3	3	2									
CO 3	3	3	2									
CO 4	3	3	2									
CO 5	3	3	2									

Assessment Pattern

Bloom's Category	Continuous Assessment Tests		End Semester Examination
	1	2	
Remember	10	10	10
Understand	20	20	20
Apply	20	20	70
Analyse			
Evaluate			
Create			

Mark distribution

Total Marks	CIE	ESE	ESE Duration
150	50	100	3 hours

Continuous Internal Evaluation Pattern:

Attendance	: 10 marks
Continuous Assessment Test (2 numbers)	: 25 marks
Assignment/Quiz/Course project	: 15 marks

End Semester Examination Pattern: There will be two parts; Part A and Part B. Part A contain 10 questions with 2 questions from each module, having 3 marks for each question. Students should answer all questions. Part B contains 2 questions from each module of which student should answer any one. Each question can have maximum 2 sub-divisions and carry 14 marks.

Course Level Assessment Questions**Course Outcome 1 (CO1):**

1. Explain D' Alembert's principle.
2. Determine analytically the forces such as piston effort, force in the connecting rod and side thrust on the cylinder walls of a reciprocating engine.
3. Draw the force polygon of a four bar mechanism.
4. Use virtual work and determine the external torque required to be applied in the case of a slider-crank engine.

Course Outcome 2 (CO2)

1. Define coefficient of fluctuation of energy
2. Draw turning moment diagrams for single cylinder double stroke steam engine.
3. Find the centrifugal stress in a flywheel for a given tangential speed.
4. Determine the maximum fluctuation of energy for a multi cylinder engine.

Course Outcome 3 (CO3)

1. Distinguish between static balancing and dynamic balancing.
2. What is single plane balancing? Explain.
3. Draw the force polygon and couple polygon when several masses rotate in different (parallel) planes.
4. Explain i) hammer blow ii) variation in tractive effort and iii) swaying couple in locomotives
5. What do you mean by primary and secondary unbalanced forces?

Course Outcome 4 (CO4):

1. Derive an expression relating the stress in a flywheel and its linear speed.
2. Describe with neat sketches the effects of gyroscopic couple on pitching, rolling and steering of a ship
3. Find an expression for the angle of heel for a two wheeler

4. Define coefficient of fluctuation of energy and maximum fluctuation of energy.

Course Outcome 5 (CO5):

1. Explain the energy method and Newton's method to determine the natural frequencies of a single degree of freedom system.
2. Derive an expression for the logarithmic decrement.
3. Find the forced response of a damped single degree of freedom vibrating system subjected to a harmonic excitation.
4. Distinguish between motion transmissibility and force transmissibility.
5. What is whirling? Derive an expression for the critical speed of a shaft.

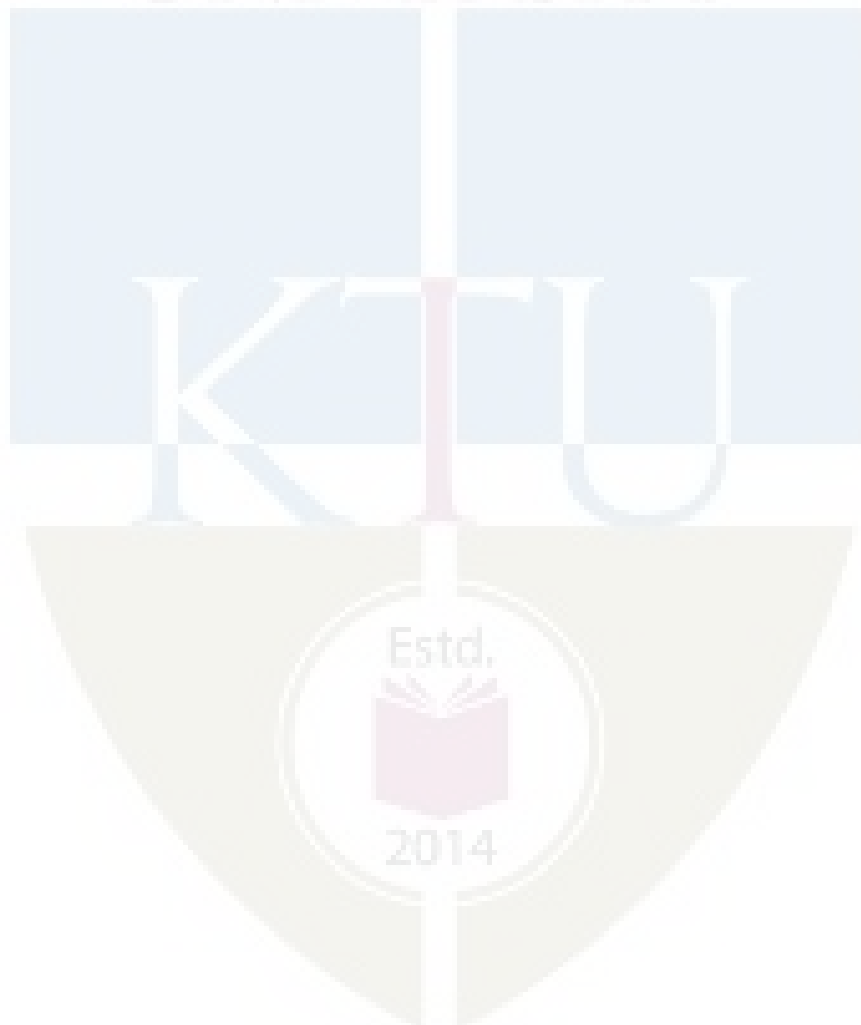

MODEL QUESTION PAPER
APJ ABDUL KALAM TECHNOLOGICAL UNIVERSITY
V SEMESTER BTECH DEGREE EXAMINATION
MET381: DYNAMICS OF MACHINES

Maximum:100 Marks

Duration:3 hours

PART A

Answer all questions, each question carries 3 marks

1. Explain virtual work method of force analysis of a four-bar mechanism.
2. What is meant by equivalent dynamic systems?
3. Define coefficient of fluctuation of energy and coefficient of fluctuation of speed.
4. Why flywheels are required?
5. Distinguish between static and dynamic balancing.
6. What is meant by partial balancing? List the effects of partial balancing.
7. Describe the effect of gyroscopic couple on the stability of a two-wheeler while negotiating a curve.
8. Define coefficient of fluctuation of speed and coefficient of fluctuation of energy.
9. Explain the energy method of obtaining the natural frequency of a single degree of freedom vibrating system.
10. Explain transmissibility. (10×3=30Marks)

PART B

Answer one full question from each module

MODULE 1

11. a) A slider crank mechanism of crank radius 60 mm and connecting rod length 240 mm is acted upon by 2 kN gas force at its piston. Calculate the torque to be applied on the crank to make the mechanism in static equilibrium when the crank makes 60° with the line of stroke. Use graphical method. (9 marks)
b) Distinguish between static and dynamic force analyses. (5 marks)
12. a) State and explain D' Alembert's principle. (4 marks)

b) The ratio of connecting rod length to crank length of a vertical gasoline engine is 4. The engine bore and stroke are 8 cm and 10 cm respectively. The mass of the reciprocating parts is 1 kg. The gas pressure on the piston is 6 bar, when it has moved 40° from the inner dead centre during the power stroke. Determine:

- i. net load on the piston
- ii. net load on the gudgeon pin and the crank pin
- iii. thrust on the cylinder walls
- iv. thrust on the crank bearing

MODULE 2

13. a) Derive an expression for the centrifugal stress in a flywheel as a function of the tangential velocity. (5 marks)

b) A machine is coupled to a two stroke engine which produces a torque of $800 + 180 \sin 3\theta$ Nm where θ is the crank angle. The mean engine speed is 400 rpm. The flywheel and the other rotating parts attached to the engine have a mass of 350 kg at a radius of gyration of 220 mm. Calculate: i) the power of the engine and ii) the total fluctuation of speed of the flywheel. (9 marks)

14. a) Draw the turning moment diagram for a 4 stroke diesel engine. (4 marks)

b) The turning moment diagram for a multi cylinder engine has been drawn to a scale of 1 cm to 5000 Nm torque and 1 cm to 60° respectively. The intercepted areas between output torque curve and mean resistance line taken in order from one end are: -0.3; +4.1; -2.8; +3.2; -3.3; +2.5; -3.6; +2.8; -2.6 square cm when the engine is running at 800 rpm. The engine has a stroke of 30 cm and the fluctuation of speed is not to exceed 2% of the mean speed. Determine a suitable diameter and cross-section of the flywheel rim for a limiting value of shaft centrifugal stress of $280 \times 10^5 \text{ N/m}^2$. The material density may be assumed as 7.2 g/cm^3 . Assume thickness of the rim to be $\frac{1}{4}$ of the width.

(10 marks)

MODULE 3

15. a) Four masses 200 kg, 300 kg, 240 kg and 260 kg with radii of rotation are positioned at 20 cm, 15 cm, 25 cm and 30 cm respectively. Their corresponding angular positions with respect to mass 200 kg are 45° , 75° and 135° . Find the

magnitude and position of the balancing mass required if the radius of rotation is 20 cm. (10 marks)

b) Dynamically balanced system is statically balanced, but not vice versa. Give your comments. (4 marks)

16. a) Describe the effects of partial balancing of reciprocating engines. (9 marks)

b) Four masses are attached to shaft at planes A, B, C and D at equal radii. The distance of planes B, C and D from A are 50 cm, 60 cm and 130 cm respectively. The masses at A, B and C are 60 kg, 55 kg and 80 kg respectively. If the system is in complete balance, determine the mass at D and the position of masses B, C and D with respect to A. (10 marks)

MODULE 4

17. a) Explain spin vector, precession vector, gyroscopic applied torque vector and gyroscopic reactive torque vector. (4 marks)

b) Explain the effects of gyroscopic couple on the stability of a four wheeler while it negotiates a curve. (10 marks)

18. a) What is the function of a flywheel? (4 marks)

b) Determine the maximum and minimum speeds of a flywheel of mass 25 kg and radius of gyration of 10 cm when the fluctuation of energy is 54.5 Nm. The mean speed of the engine is 1000 rpm. (10 marks)

MODULE 5

19. a) A machine of mass 1000 kg is acted upon by an external force of 2450 N at a speed of 1500 rpm. To reduce the effect, vibration isolators made of rubber having a static deflection of 2 mm under the machine load and an estimated damping factor of 0.2 are used. Determine the following:

- i. Force transmitted to the foundation
- ii. Amplitude of vibration of machine
- iii. Phase lag between the transmitted force and the displacement of mass.

(10 marks)

b) Distinguish between motion transmissibility and displacement transmissibility.

(5 marks)

20. a) A damped spring mass system has mass 3 kg, stiffness 100 N/m and damping coefficient 3 Ns/m. Determine the following:

- i. Damping ratio
- ii. Damped natural frequency
- iii. Logarithmic decrement
- iv. Ratio of two successive amplitudes (8 marks)

b) Describe briefly Newton's method and energy method used for obtaining the natural frequencies. (6 marks)

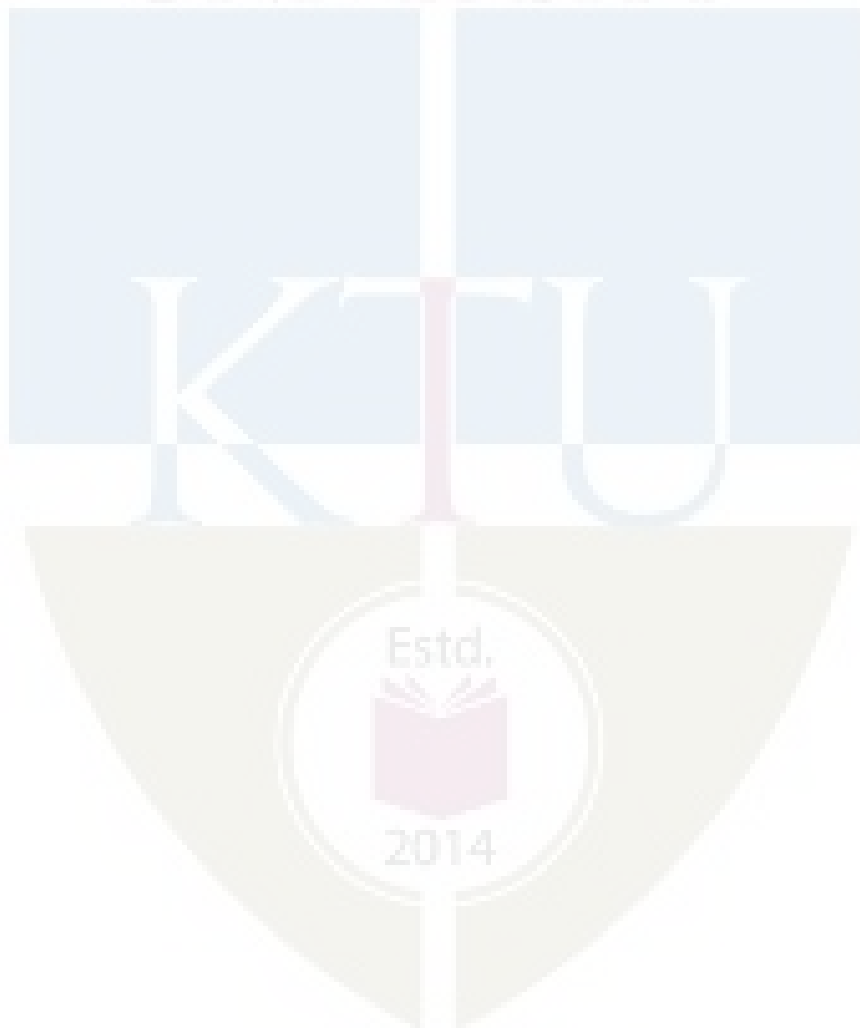

Module 1

Static and dynamic force analysis of mechanisms (four bar linkages only)-graphical method-virtual work method -D'Alembert's principle-equivalent dynamic systems-reciprocating engine force analysis

Module 2

Flywheels-turning moment diagrams for steam engines-four stroke internal combustion engine and multi cylinder engines-coefficient of fluctuation of speed-coefficient of fluctuation of energy-design of flywheels.

Module 3

Balancing: static balancing-dynamic balancing-balancing of several masses revolving in a single plane-several masses in different parallel planes-balancing of single cylinder reciprocating engines-partial balancing and its effects-balancing of multi cylinder inline engines

Module 4

Gyroscopic couple-effects on the stability of automobiles-two wheeler and four wheeler, stability of ships and air crafts-Flywheels-turning moment diagrams-coefficient of fluctuation of energy, coefficient of fluctuation of speed

Module 5

Vibration-free vibration of single degree of freedom systems-equation of motion-Newton's method-energy method-natural frequency-undamped and damped systems-logarithmic decrement-forced vibration-response of SDOF systems to harmonic excitation-whirling of shaft-vibration absorber-transmissibility

Text Books

1. Ballaney, P. L. Theory of machines and mechanisms. Khanna Publishers, 2010.
2. Rattan S S, Theory of Machines, Tata McGraw-Hill Education, 2005.

Reference Books

1. Charles E Wilson and J Peter Sadler, Kinematics and Dynamics of Machinery, Tata McGraw-Hill Education, 2008.
2. Amithabha Ghosh and Asok Kumar Malik, Theory of Mechanisms and Machines, East West Press, 2011
3. Thomas Bevan, Theory of Machines, Pearson, 2013.

No	Topic	No. of Lectures
1		
1.1	Static analysis of mechanisms-graphical method-four bar mechanisms	3
1.2	Virtual work method -D'Alembert's principle-equivalent dynamic systems	3
1.3	Reciprocating engine force analysis	2
2		
2.1	Flywheels, turning moment diagrams-steam engines-four stroke internal combustion engines and multi cylinder engines	4
2.2	Multi cylinder engine-coefficient of fluctuation of speed-coefficient of fluctuation of energy-design of flywheels	4
3		
3.1	Static and dynamic balancing- balancing of several masses in a single plane-force polygon	3
3.2	Balancing of several masses in parallel planes-couple polygon	3
3.3	Balancing of reciprocating masses-effects of partial balancing	2
3.4	Balancing of multi cylinder in-line engines	2
4		
4.1	Gyroscopic couple-introduction-spin, precession and applied couple vectors	2
4.2	Effects of gyroscopic couple on the stability of two wheeler and four wheeler	2
4.3	Effects on the stability of sea vessels and air crafts	3
4.4	Flywheels-turning moment diagrams-coefficient of fluctuation of energy, coefficient of fluctuation of speed	3
5		
5.1	Vibration-free vibration of single degree of freedom systems-equation of motion-Newton's method-energy method-natural frequency	3
5.2	Damped systems-logarithmic decrement-forced vibration-response of SDOF systems to harmonic excitation	3
5.3	Whirling of shaft-vibration absorber- transmissibility	3

CODE MET383	COURSE NAME THERMAL SCIENCE AND ENGINEERING	CATEGORY	L	T	P	CREDIT
		VAC	3	1	0	4

Preamble: This course involve the application of principles studied in thermodynamics to different energy conversion systems like steam turbine, steam powerplant, IC engines and refrigeration systems. This course also covers the methods for improving and evaluating the performance of different energy conversion systems. This course also helps to understand the combustion phenomenon in IC engines.

Prerequisite: MET284 Thermodynamics (Minor)

Course Outcomes: After the completion of the course the student will be able to

CO 1	Explain the working of steam power cycle and related components
CO 2	Discuss the working of steam turbines and methods for evaluating the performance
CO 3	Illustrate the performance testing and evaluation of IC engines
CO 4	Explain the combustion phenomenon and pollution in IC engines
CO 5	Discuss the principles of refrigeration and air-conditioning and basic design considerations

Mapping of course outcomes with program outcomes

	PO 1	PO 2	PO 3	PO 4	PO 5	PO 6	PO 7	PO 8	PO 9	PO 10	PO 11	PO 12
CO 1	3	3	2									
CO 2	3	3	2									
CO 3	3	3	2									
CO 4	3	3	2									
CO 5	3	3	2									

Assessment Pattern

Bloom's Category	Continuous Assessment Tests		End Semester Examination
	1	2	
Remember	10	10	10
Understand	20	20	20
Apply	20	20	70
Analyse			
Evaluate			
Create			

Mark distribution

Total Marks	CIE	ESE	ESE Duration
150	50	100	3 hours

Continuous Internal Evaluation Pattern:

Attendance	: 10 marks
Continuous Assessment Test (2 numbers)	: 25 marks
Assignment/Quiz/Course project	: 15 marks

End Semester Examination Pattern: There will be two parts; Part A and Part B. Part A contain 10 questions with 2 questions from each module, having 3 marks for each question. Students should answer all questions. Part B contains 2 questions from each module of which student should answer any one. Each question can have maximum 2 sub-divisions and carry 14 marks.

Course Level Assessment Questions

Course Outcome 1 (CO1):

1. In a reheat Rankine cycle, steam at a pressure of 40 bar and 300°C is expanded through a turbine to a pressure of 4 bar. It is then heated at a constant pressure to 300°C and then expanded to 0.1 bar. Estimate the work done per kg of steam flowing through the turbine, the amount of heat supplied during the reheat process and the cycle efficiency. Neglect pump work.
2. Explain the term boiler mountings and accessories
3. With the help of a figure explain the working of Babcock and Wilcox boiler.

Course Outcome 2 (CO2):

1. In an impulse steam turbine, steam issues from the nozzle with a velocity of 1200 m/s. The nozzle angle is 20° and the mean blade velocity is 400 m/s. The inlet and outlet blade angles are equal. The blade velocity coefficient is 0.8. The mass of steam flowing through the turbine per hour is 950 kg. Calculate: (i) Blade angles. (ii) Relative velocity of steam entering the blades (iii) Tangential force on the blades. (iv) Power developed. (v) Blade efficiency.
2. Derive the conditions for maximum efficiency of a Parsons reaction turbine.
3. Discuss the means of improving the performance of a steam turbine.

Course Outcome 3(CO3):

MECHANICAL ENGINEERING

1. A 4-cylinder four stroke petrol engine is working based on the following data: Air-fuel ratio by weight = 15:1, calorific value of the fuel = 45000 kJ/kg, mechanical efficiency = 80 %, air- standard efficiency = 54 %, relative efficiency = 70 %, volumetric efficiency = 75 %, stroke/bore ratio = 1.25, suction conditions = 1 bar and 30 °C, r.p.m. = 2500, brake power = 70 kW. Calculate: (i) Compression ratio. (ii) Indicated thermal efficiency. (iii) Brake specific fuel consumption. (iv) Bore and stroke.
2. Discuss the working of a rotary engine and its merits and demerits over conventional IC engines.
3. Explain the performance testing of IC engines

Course Outcome 4 (CO4):

1. Explain equivalence ratio and its significance in IC engine combustion.
2. Explain different stages of SI engine combustion with the help of pressure-crank angle diagram.
3. Discuss detonation in SI engine, cause and effects and the engine variable influencing the same.

Course Outcome 5 (CO5):

1. Derive the expression for COP of an ideal air refrigeration cycle.
2. Explain the factors affecting human comfort
3. Write brief note on summer air conditioning

MODEL QUESTION PAPER

APJ ABDUL KALAM TECHNOLOGICAL UNIVERSITY

V SEMESTER BTECH DEGREE EXAMINATION

MET383: THERMAL SCIENCE AND ENGINEERING

Maximum: 100 Marks

Duration: 3 hours

Use of Steam tables, Refrigeration tables, Charts and Psychrometric chart is permitted.

PART A

Answer all questions, each question carries 3 marks

1. Explain Rankine cycle with help of a T-S diagram.
2. Differentiate between fire tube boiler and water tube boiler.
3. List the difference between throttle governing and nozzle governing.
4. Explain degree of reaction of a steam turbine.
5. Explain the term MEP
6. Explain the meaning of Specific Fuel
7. Explain the term Preignition
8. What do you meant by Octane number?
9. Why reversed Carnot cycle is practically impossible to execute?
10. Differentiate between specific humidity and relative humidity (10×3=30 Marks)

PART B

Answer one full question from each module

MODULE 1

11. a) Steam at a pressure of 15 bar and 250 °C is expanded through a turbine to a pressure of 4 bar. It is then reheated at constant pressure to initial temperature of 250 °C and finally expanded to condenser pressure of 0.1 bar. Calculate efficiency of the cycle. Pump work can be neglected. (8 marks)
- b) Explain in detail different boiler mountings and accessories. (6 marks)

12. a) With the help of a neat figure explain the working of a Benson boiler. What are its merits over other boilers? (8 marks)
- b) With the help of T-s and p-h diagram explain the significance of binary vapour cycle. (6 marks)

MODULE 2

13. a) Derive the condition for maximum efficiency of a reaction turbine. (6 marks)
- b) With the help of figures enumerate the difference between pressure compounding and velocity compounding of steam turbines. (8 marks)
14. a) What do you mean by reheat factor? List the parameters influencing the value of reheat factor. (4 marks)
- b) In an impulse steam turbine, steam issues from the nozzle with a velocity of 1200 m/s. The nozzle angle is 20° and the mean blade velocity is 400 m/s. The inlet and outlet blade angles are equal. The blade velocity coefficient is 0.8. The mass of steam flowing through the turbine per hour is 950 kg. Calculate: (i) Blade angles. (ii) Relative velocity of steam entering the blades. (iii) Tangential force on the blades. (iv) Power developed. (v) Blade efficiency. (10 marks)

MODULE 3

15. a) Discuss the terms a) Mechanical efficiency b) Volumetric Efficiency c) Thermal efficiency of an IC engine (9 marks)
- b) Discuss the effect of variable specific heat in actual cycle of IC engines. (5 marks)
16. The following observations were recorded during a trial of a four stroke single cylinder diesel engine for a trial duration of 30 min. Fuel consumption is 4 liters, Calorific value of fuel 43 MJ/kg, specific gravity of the fuel = 0.8, average area of indicator diagram = 8.5 cm^2 , length of indicator diagram = 8.5 cm, spring constant = 5.5 bar/cm, brake load = 150 kg, spring balance reading = 20 kg, effective brake wheel diameter = 1.5 m, speed = 200 rpm, cylinder diameter = 30 cm, stroke = 45 cm. Calculate i) indicated power ii) brake power iii) mechanical efficiency iv) specific fuel consumption in kg/kWh and v) indicated thermal efficiency. (14 marks)

MODULE 4 MECHANICAL ENGINEERING

17. a) With the help of pressure-crank angle diagram explain different stages of CI engine combustion. (8 marks)
- b) Explain the phenomenon of detonation in SI engine based on autoignition theory. (6 marks)
18. With the help of figures compare different types of SI and CI engine combustion chambers. (14 marks)

MODULE 5

19. a) A freezer of 20 TR capacity has evaporator and condenser temperature of $-30\text{ }^{\circ}\text{C}$ and $25\text{ }^{\circ}\text{C}$ respectively. The refrigerant R-12 is sub-cooled by $4\text{ }^{\circ}\text{C}$ before entering the expansion valve and is superheated by $5\text{ }^{\circ}\text{C}$ before entering the evaporator. If a six cylinder single acting compressor with stroke equal to bore running at 1000 rpm. is used. Determine i) COP ii) Theoretical piston displacement per minute iii) Theoretical bore and stroke. (9 marks)
- b) Derive an expression for COP of a Reversed Brayton cycle for air refrigeration system. (5 marks)
20. a) Explain the concept of summer air conditioning (10 marks)
- b) Define i) DPT ii) RH ii) SHF and iv) ADP. (4 marks)

Module 1

Steam engineering- Rankine cycle, Modified Rankine cycle, Relative efficiency, Improvement in steam cycles-Reheat, Regenerative and Binary vapour cycle. Steam Boilers: Types of boilers, Cochran boiler, Babcock and Wilcox boiler, Benson boiler, La Mont boiler, Boiler Mountings and Accessories.

Module 2

Steam turbines: classification, compounding of turbines-pressure velocity variation, velocity diagrams, work done, efficiency, condition for maximum efficiency, multistage turbines-condition line, stage efficiency. Steam turbine performance-reheat factor, degree of reaction, cycles with reheating and regenerative heating, governing of turbines.

Module 3

Actual cycle analysis of IC engines- Deviation of actual engine cycle from ideal cycle, Performance Testing of I C Engines- Indicator diagram, mean effective pressure. Torque, Engine power- BHP, IHP. Engine efficiency, mechanical efficiency, volumetric efficiency, thermal efficiency, relative efficiency and Specific fuel consumption.

Module 4

Combustion in I.C. Engines- Analysis of fuel combustion-A/F ratio, equivalence ratio, excess air. Combustion phenomena in S.I. engines; Ignition limits, stages of combustion in S.I. Engines, Ignition lag, velocity of flame propagation, auto ignition, detonation; effects of engine variables on detonation; theories of detonation, octane rating of fuels; pre-ignition; S.I. engine combustion chambers. Combustion in C.I. Engines; delay period; variables affecting delay period; knock in C.I. engines, Cetane rating; C.I. engine combustion chambers.

Module 5

Refrigeration– Reversed Carnot cycle, Air refrigeration system- Reversed Joule cycle. Vapour compression systems-simple cycle - representation on T- s and P- h Diagrams. Psychrometric properties – specific humidity, relative humidity and degree of saturation, thermodynamic equations, enthalpy of moisture, DBT, WBT and DPT, psychrometers, psychrometric chart. Comfort and industrial air conditioning, Comfort air conditioning-factors affecting human comfort, Effective temperature, comfort chart, Summer air conditioning

Text Books

1. Rudramoorthy , Thermal Engineering, McGraw Hill Education India, 2003.
2. R.K Rajput, Thermal Engineering, Laxmi publications, 2010.
3. Arora C. P, Refrigeration and Air-Conditioning, McGraw-Hill, 2008.

4. Arora S. C. and Domkundwar, Refrigeration and Air-Conditioning, Dhanpat Rai, 2010.

Reference Books

1. V. Ganesan, Fundamentals of IC engines, Tata McGraw-Hill, 2002.
2. J.B.Heywood, I.C engine fundamentals. McGraw-Hill, 2011.
3. Rathore, Thermal Engineering, McGraw Hill Education India, 2010.
4. Dossat. R. J, Principles of Refrigeration, Pearson Education India, 2002.
5. Stoecker W.F, Refrigeration and Air-Conditioning, McGraw-Hill Publishing Company, 2009.

Course Contents and Lecture Schedule

No	Topic	No. of Lectures
1		
1.1	Steam engineering- Rankine cycle, Modified Rankine cycle, Relative efficiency, Improvement in steam cycles-Reheat, Regenerative and Binary vapor cycle.	4
1.2	Steam Boilers: Types of boilers, Cochran boiler, Babcock and Wilcox boiler, Benson boiler.	3
1.3	La Mont boiler, Boiler Mountings and Accessories.	2
2		
2.1	Steam turbines: classification, compounding of turbines-pressure velocity variation, velocity diagrams.	3
2.2	Work done, efficiency, condition for maximum efficiency, multistage turbines-condition line, stage efficiency.	3
2.3	Steam turbine performance-reheat factor, degree of reaction, cycles with reheating and regenerative heating, governing of turbines.	3
3		
3.1	Actual cycle analysis of IC engines- Deviation of actual engine cycle from ideal cycle	2
3.2	Performance Testing of I C Engines- Indicator diagram, mean effective pressure. Torque	2
3.3	Engine power- BHP, IHP. Engine efficiency, mechanical efficiency, volumetric efficiency, thermal efficiency	3
3.4	Relative efficiency, Specific fuel consumption.	2
4		
4.1	Combustion in I.C. Engines- Analysis of fuel combustion-A/F ratio, equivalence ratio, excess air.	1
4.2	Combustion phenomena in S.I. engines; Ignition limits, stages of combustion in S.I. Engines, Ignition lag, velocity of flame	3

	propagation, auto ignition, detonation; effects of engine variables on detonation; theories of detonation,	
4.3	Octane rating of fuels; pre-ignition; S.I. engine combustion chambers. Combustion in C.I. Engines; delay period; variables affecting delay period;	3
4.4	knock in C.I. engines, Cetane rating; C.I. engine combustion chambers.	2
5		
5.1	Refrigeration– Reversed Carnot cycle, Air refrigeration system- Reversed Joule cycle.	2
5.2	Vapour compression systems-simple cycle - representation on T- s and P- h Diagrams.	2
5.3	Psychrometric properties – specific humidity, relative humidity and degree of saturation-	1
5.4	Thermodynamic equations- enthalpy of moisture- DBT, WBT and DPT–psychrometers, psychrometric chart.	2
5.5	Comfort and industrial air conditioning, Comfort air conditioning- factors affecting human comfort, Effective temperature, comfort chart, Summer air conditioning,	2



CODE	MACHINE TOOLS ENGINEERING	CATEGORY	L	T	P	Credits
MET385		VAC	3	1	0	4

Preamble:

This course facilitate students to learn about various machine tools and operations performed on them. Theoretical foundation offered by this course must help the learners to make appropriate decisions vis-a-vis preliminary planning and selection of machine tools, acquiring adequate supervisory skills and to help the learners to efficiently interact with their peers to arrive at solutions for day-to-day shop floor problems.

Prerequisite:
MET285 Material Science and Technology (Minor), MET286 Manufacturing Technology (Minor)

Course Outcomes: After the completion of the course the student will be able to:

CO 1	Describe basic concepts involved in metal cutting.
CO 2	Differentiate between machine tools, their components, operations carried out and their unique metal removing mechanisms.
CO 3	Describe how to specify machine tools and cutting tools.
CO 4	Calculate the time required for machining.
CO 5	Clarify advantages of CNC over manual machine tools.
CO 6	Clarify how non-conventional machining techniques are advantageous to finish jobs with intricate profiles and closer tolerances.

Mapping of course outcomes with program outcomes:

	PO 1	PO 2	PO 3	PO 4	PO 5	PO 6	PO 7	PO 8	PO 9	PO 10	PO 11	PO 12
CO 1	3	-	-	-	-	-	-	-	2	-	-	-
CO 2	1	-	1	-	3	-	-	-	2	1	-	-
CO 3	-	-	-	2	-	-	-	-	2	-	1	-
CO 4	3	2	-	-	-	-	-	-	2	-	-	-
CO 5	-	-	-	-	2	-	-	-	2	-	-	2
CO 6	-	-	-	-	-	-	1	-	2	-	-	1

Assessment Pattern

Bloom's Category	Continuous Assessment Tests		End Semester Examination (marks)
	1 (marks)	2 (marks)	
Remember	15	15	35
Understand	15	15	35
Apply	10	10	15
Analyse	10	10	15
Evaluate	-	-	-
Create	-	-	-

Mark distribution

Total Marks	CIE	ESE	ESE Duration
150	50	100	3 hours

Continuous Internal Evaluation Pattern:

Attendance	: 10 marks
Continuous Assessment Test (2 numbers)	: 25 marks
Assignment/Quiz/Course project	: 15 marks

End Semester Examination Pattern: There will be two parts; Part A and Part B. Part A contain 10 questions with 2 questions from each module, having 3 marks for each question. Students should answer all questions. Part B contains 2 questions from each module of which student should answer any one. Each question can have maximum 2 sub-divisions and carry 14 marks.

Course Level Assessment Questions

Course Outcome 1 (CO1):

1. Describe the geometry of a single point cutting tool with a neat diagram.
2. Define machinability.
3. List various cutting tool materials and their applications.

Course Outcome 2 (CO2):

1. Examine two reasons for centre drilling on lathe.
2. Differentiate between up milling and down milling.
3. Differentiate a wire-cut EDM from a general purpose EDM.

Course Outcome 3 (CO3):

1. List all specification parameters of a lathe.
2. Specify a plain milling cutter.
3. Specify a twist drill.

Course Outcome 4 (CO4):

1. Calculate the time required for drilling a 20 mm hole in metal blank having thickness of 36 mm. The cutting speed is 15 metres/minute and feed is 0.2 mm/revolution.
2. Calculate the r.p.m. of lathe to obtain a cutting speed of 25 metres/minute, when turning a rod of diameter 32 mm diameter.
3. Calculate machining time for cylindrical grinding, if length of longitudinal travel = 500 mm, feed = 1.0 mm/revolution and work piece r.p.m = 500 in a single pass.

Course Outcome 5 (CO5):

1. Clarify whether a conventional machine tool can be retrofitted with a CNC system.
2. Describe advantages of CNC system in manufacturing.
3. Distinguish between open loop system and closed loop system by giving an example for each.

Course Outcome 6 (CO6):

1. Describe advantages of WJM over traditional punching/manual cutting
2. Compare process capabilities of conventional drilling and laser beam drilling.
3. Clarify why an EDM is not used as a replacement to CNC milling machine.

MODEL QUESTION PAPER
FIFTH SEMESTER MECHANICAL ENGINEERING ENGINEERING
MET385 MACHINE TOOLS ENGINEERING

Max. Marks: 100

Duration: 3 hours

Part–A

Answer all questions. Each question carries 3 marks.

1. State the effect of cutting speed, feed and depth of cut on surface finish obtainable.
2. Explain why built up edge on a tool is undesirable.
3. A brass pin of 500 mm length and 40 mm diameter is turned on a lathe to 38.8 mm diameter in one pass. The cutting speed is 60 metres/minute and feed is 0.8 mm/min. Calculate the machining time.
4. How do you specify (a) portable drilling machine (b) radial drilling machine (c) multiple spindle drilling machine.
5. List various operations that can be performed on a milling machine.
6. Differentiate between grain and grade in a grinding wheel.
7. Bring out the differences between continuous path control and point-to-point positioning.
8. List the generic advantages of CNC system over their manual counterparts.
9. Discuss the characteristics of dielectric fluids used in EDM.
10. List the advantage of WJM over traditional cutting.

Part–B

Answer one full question from each module.

Module I

11. (a) Sketch the three views of a 25 mm single point square tool bit having tool signature as indicated below: 15,15,10,10,15,10 (3 mm) (7 marks)
- (b) Define machinability. Discuss all variables affecting machinability. (7 marks)
12. (a) Discuss various cutting tool materials and their applications.
- (b) Define tool failure. List and explain 2 reasons for normal tool wear. (7 marks)

Module II

13. Describe construction details of an engine lathe with a neat illustration. (14 marks)
14. Draw and explain any four operations carried out in a lathe. (14 marks)

Module III

15. Draw and explain up milling and down milling. Decide which type is suitable to prevent backlash. (14 marks)

16. List all factors to be considered for selection of grinding wheels. Discuss each in detail.

(14 marks)

Module IV

17. Discuss all elements of a CNC system with a suitable block diagram.

(14 marks)

18. Discuss construction details of a CNC lathe and compare process capability of CNC lathe with that of a manual lathe.

(14 marks)

Module V

19. Describe ultrasonic drilling process giving areas of application.

(14 marks)

20. Discuss construction and operation of a wire-cut EDM system with the help of a suitable diagram.

(14 marks)

Syllabus

Module 1

Definition of machining–brief history of machining–role of machining in society. Introduction to metal cutting: Elements of cutting process– orthogonal cutting– mechanism of chip formation–machining variables -types of chips–chip breaker– geometry of single point cutting tool– tool nomenclature- speed, feed, depth of cut – cutting fluids- effect of machining variables on surface roughness- Cutting tool materials–types–application. Machinability–tool life and wear.

Module 2

General purpose machine tools – Lathe: principle of operation of lathe–construction details of lathe–work holding and tool holding parts of lathe– types of lathe and specification–machining time calculation on lathe–main operations. Drilling Machines: principle of operation–construction details- work holding and tool holding devices– types of drilling machine and specification. Twist drill geometry–specification–calculation of machining time in drilling.

Module 3

Milling machines: Principle of operation of milling machine–types and specifications–principal parts–work holding devices–types of milling cutters–elemental milling motions–up milling, down milling calculation of machining time. Grinding machines: classification –operations– surface, cylindrical and centerless grinding–grinding wheels–specification–types of abrasives, grain size. Dressing and truing of grinding wheels–selection of grinding wheels.

Module 4

Machine tools with Computer Numeric Control: Principle of operation of CNC system–basic components of CNC system– classification of CNC systems– open loop control and closed loop

control– point to point and continuous path control– absolute positioning and incremental positioning–CNC lathe–construction and operation – CNC milling machine–construction and operation (elementary treatment only)

Module 5

Non-conventional techniques in machining: Electric Discharge Machining (EDM): mechanisms of metal removal- elements of an EDM– spark generation– application of EDM – Wire-cut EDM-features. UltraSonic Machining (USM): mechanism of metal removal- elements of USM-applications. Water Jet Machining (WJM): mechanism of metal removal-elements of WJM-applications.

Text Books

1. R.K.Jain, Production Technology, Khanna publishers, 17th ed., 2013.
2. Hajra Choudhary, Elements of Workshop Technology Vol. II, Media Promoters & Publishers Pvt. Ltd., 2010.

Reference Books

1. Serope Kalpakjian, Steven R. Schmid – Manufacturing Engineering and Technology, 8th ed. Pearson.
2. Chapman W.A.J., Workshop Technology, Viva books (P) Ltd, 1998.
3. Peter J. Hoffman, Eric S. Hopewell et al., Precision Machining Technology, Cengage Learning, 2014.
4. Malkin Stephen, Grinding Technology: Theory and application of Machining with Abrasives, Industrial press, 2008.

Course Contents and Lecture Schedule

No	Topic	No. of Lectures	COs
1.1	Definition of Machining–brief history of machining–role of machining in society – automotive- aerospace– medical–consumable goods.	1	CO1
1.2	Introduction to metal cutting–elements of cutting process–work piece-tool interaction in orthogonal cutting- rake angle, shear angle, cutting angle, clearance angle–mechanism of chip formation–chip breaker.	1	CO1
1.3	Machining variables- geometry of chips (types of chips)- cutting speed, feed, depth of cut- tool geometry (single point)-nomenclature-cutting fluids.	3	CO1
1.4	Effect of machining variables on surface roughness.	2	CO1
1.5	Cutting tool materials and application.	1	CO1
1.6	Machinability-factors affecting it –machinability index.	1	CO1
1.7	Tool life and tool wear.	1	CO1
2.1	General purpose machine tools– lathe- principle and operation of lathe-how to specify a lathe-types of lathe.	1	CO2 CO3
2.2	Construction details of engine lathe-work holding and tool holding parts of lathe.	2	CO2
2.3	Main operations in lathe- machining time calculation of plain turning.	2	CO4

2.4	Drilling machines – principle of operation-construction details.	1	CO2
2.5	Work holding and tool holding devices.	2	CO2
2.6	Types of drilling machine- specification of radial drilling machine.	1	CO3
2.7	Twist drill geometry and specification- calculation of drilling time.	1	CO4
3.1	Milling machine- purpose and principle of operation-types an specification.	1	CO2
3.2	Differentiate Horizontal milling machine and vertical milling machine – principal parts and work holding devices of vertical milling machine.	1	CO2
3.3	Types of milling cutters- elemental milling movements- up milling, down milling – calculation of plain milling time.	2	CO4
3.4	Grinding machines- classification- surface, cylindrical and centre less grinding.	1	CO2
3.5	Grinding wheels–specification–types of abrasives, grain size–dressing and truing of grinding wheels–selection of grinding wheels.	3	CO3
4.1	Machine tools with CNC- principle of operation of CNC – basic components (block diagrams)	2	CO2
4.2	Classification of CNC systems– open loop control and closed loop control– point-to-point and continuous path control– absolute positioning and incremental positioning.	2	CO5
4.3	CNC lathe- construction and operation (elementary treatment)	2	CO5
4.4	CNC milling machine- construction and operation (elementary treatment)	2	CO5
5.1	Non-conventional techniques in machining: Electric Discharge machining (EDM): mechanism of metal removal- elements of an EDM– physics of spark generation.	2	CO6
5.2	Applications of EDM process.	1	CO6
5.3	Wire-cut EDM-features and applications.	1	CO6
5.4	Ultrasonic Machining (USM): mechanism of metal removal- elements of USM-applications.	2	CO6
5.5	Water Jet Machining (WJM): mechanism of metal removal-elements of WJM- applications.	2	CO6

APJ ABDUL KALAM
TECHNOLOGICAL
UNIVERSITY

SEMESTER V

HONOURS



Assessment Pattern

Blooms Category	Continuous Assessment Tests		ESE
	1	2	
Remember			
Understand	40	40	80
Apply		10	10
Analyse	10		10
Evaluate			
Create			

Mark Distribution

Total Marks	CIE	ESE	ESE Duration
150	50	100	3 Hrs

Continuous Internal Evaluation Pattern

Attendance	10
Continuous Assessment Tests (2 nos)	25
Assignments/ Quiz/ Course Project	15

End Semester Examination Pattern: There will be two parts; Part A and Part B. Part A contain 10 questions with 2 questions from each module, having 3 marks for each question. Students should answer all questions. Part B contains 2 questions from each module of which student should answer any one. Each question can have maximum 2 sub-divisions and carry 14 marks.

COURSE LEVEL ASSESSMENT QUESTIONS

Course Outcome 1 (CO1): Analyse the stresses, strains and deformations of structures under 2- and 3-dimensional loading by tensorial and graphical (Mohr's circle) approaches.

1. Determine the resultant traction at a point in a plane using the stress tensor.
2. Evaluate the principal stresses, principal strains and their directions from a given state of stress or strain.
3. Write the stress tensor and strain tensor.

Course Outcome 2 (CO2): Describe the different instrument used for strain measurement materials using stress-strain relationships.

1. With help of fig, explain the construction and working of any one type of strain gauge.
2. Explain how strain can be measured over a long time at high and low temperature.
3. Explain how the delta rosette can be used for analysing the strain.

Course Outcome 3 (CO3): Describe the concept behind the measurement and instrumentation.

1. Describe Range and Sensitivity of a circuit
2. Define error, accuracy and precision with respect to measuring instrument.
3. With help of fig, Describe any one type of displacement measuring transducer.

Course Outcome 4 (CO4): Describe the concept behind Photo elasticity and brittle Coating.

1. Enumerate different steps involved in brittle coating.
2. Describe the effect of stressed model in plane polariscope.
3. Describe compensation techniques in photo elasticity.

Course Outcome 5 (CO5): Describe the different NDT methods to evaluate the strength.

1. Describe dye penetrant test with help of figure.
2. Explain penetrometer with help of figure.
3. With help of figure, explain Magnetic particle test.

MODEL QUESTION PAPER**APJ ABDUL KALAM TECHNOLOGICAL
UNIVERSITY**

FIFTH SEMESTER B.TECH DEGREE EXAMINATION

MET 393 EXPERIMENTAL STRESS ANALYSIS

Max. Marks:100

Duration: 3Hours

PART – A**(ANSWER ALL QUESTIONS, EACH QUESTION
CARRIES 3 MARKS)**

1. Define stress at a point.
2. Explain principal stresses and strain.
3. How static and dynamic strain can be measured over a strain circuits.
4. What are residual stresses? What are its beneficial and harmful effects?
5. What are transducers? What are its properties?
6. Explain the different principles of measurements
7. Define stress optic law
8. What are the main uses of photo elastic coatings?
9. Distinguish between Destructive testing and Non-destructive testing.
10. What are the properties of X rays and Gamma rays.

PART – B**(ANSWER ONE FULL QUESTION FROM EACH
MODULE)****MODULE – 1**

11. The state of stress at a point is given by the Cartesian stress tensor
- $$\begin{bmatrix} 3 & -1 & 1 \\ -1 & 5 & -1 \\ 1 & -1 & 3 \end{bmatrix}$$
- Kpa. Find (a) the stress invariant (b) characteristic equation (c) Principal stresses (d) Unit normal of the principal planes. (14marks)
12. a) Derive the expression for Cauchy's equation for stress on a given plane, normal stress & shear stress. (7marks)

- b) Derive stress compatibility equation of plane strain problems. (7marks)

MODULE – 2

13. a) With help of neat sketch, explain a mechanical strain gauge (7 marks)

- b) Explain how rectangular rosette can be analyzed for strain measurement. (7 marks)

14. a) With help of fig, explain an optical strain gauge. (7 Marks)

- b) Describe how strain can be measured over a long period at low and high temperature. (7 marks)

MODULE – 3

15. a) with help of figure, explain the working of cathode ray oscilloscope. (7 marks)

- b) With help of fig, explain the working of displacement transducer. (7 marks)

16. a) Prove that constant current potentiometer circuit has more sensitivity than that of a constant voltage circuit (7 marks)

- b) With help of fig, explain the working of force transducer. (7 marks)

MODULE – 4

- 17 a) Describe the different types of available brittle coatings. (7marks)

- b) Obtain the expression for intensity of light emerging from a plane polariscope with dark field set up. (7marks)

- 18 a) With help of fig, explain Tardy's method of compensation. (10 marks)

- b) Explain isochromatic and isoclinics fringe pattern (4 marks)

MODULE – 5

19. a) Explain laser testing methods in NDT. (7 marks)

- b) With help of fig, explain the steps involved in LPI. (7 marks)

20. a) With help of fig, explain Radiography test. (7 marks)

- b) Explain the working of X – ray fluoroscopy (7 marks)

SYLLABUS

Module 1: Analysis of deformable bodies: stress, stress at a point using Cartesian stress tensor, Cauchy's equation for stress on a given plane, normal stress & shear stress; Strain, deformation and displacement (in Cartesian coordinates), strain components, 2D plane stress and plane strain problems, principal stresses (2D & 3D), stress invariants, Mohr's circle representation for stress in 2D and problems, representation 3D stress in Mohr's circle using principal stresses as input.

Module 2: Strain measurements: strain gauges and stress gauges. Mechanical, optical and electrical gauges – Construction and applications. Variable resistance strain gauges, gauge characteristics, gauge sensitivity, static and dynamic strain – strain measurement over a long period at low and high temperature. Strain rosettes – Rectangular rosettes, Delta rosettes. Residual stresses : Beneficial and harmful effects.

Module 3: Instrumentation: Strain circuits, potentiometer circuits, Range and sensitivity, The wheatstones bridge, sensitivity, Galvanometer, Transient response, Principles of measurements: Error, Accuracy and precision , Uncertainty analysis, Curve fitting. Oscillograph, cathode ray oscilloscope, Transducers – Displacement, Force, Pressure, velocity and acceleration.

Module 4: Photo elasticity: The polariscope, Stress optic law, Polariscope arrangements – Plane polariscope and Circular Polariscope. Dark field and light field, isochromatic and isoclinics, Use of photo elastic coatings, compensation techniques. Brittle coatings: Coating stresses, Failure theories, steps in brittle coating tests.

Module 5: Non Destructive testing Methods – Types – dye penetrant methods, Radiography – X – ray and Gamma ray – X – ray fluoroscopy. Penetrameter – Magnetic particle methods. Introduction to lasers in NDT – Ultrasonic flaw detection.

Text Books

1. J. W. Dally and W. F. Riley, Experimental Stress Analysis - McGraw Hill, 1991
2. L.S. Srinath, M.R. Raghavan, K. Lingaiah, G. Gargesa, B. Pant, and K. Ramachandra, Experimental Stress Analysis, Tata Mc Graw Hill, 1984.
3. A. Mubin, Experimental Stress Analysis, Khanna Publishers, 2003.
4. Sadhu Singh, Experimental Stress Analysis, Khanna Publishers, 1996.

Reference Books

1. M. Hetenyi, Handbook of Experimental Stress Analysis, John Wiley & Sons Inc, New York, 1950
2. C.C. Perry and H.R. Lissener, Strain Gauge Primer, McGraw Hill, 2nd Ed., 1962.

3. W.J. McGonnagle-Non-destructive Testing-Mc Graw Hill, 1961.

COURSE PLAN

No	Topic	No. of Lectures
1	Module 1: Stress and Strain Analysis	9 hrs
1.1	Describe the deformation behaviour of elastic solids in equilibrium under the action of a system of forces. Describe method of sections to illustrate stress as resisting force per unit area. Stress vectors on Cartesian coordinate planes passing through a point .	1 hr
1.2	Direction cosines of a plane. Equality of cross shear (Derivation not required). Write Cauchy's equation (Derivation not required) for stress on a plane as the product of stress tensor and direction cosine vector. Normal and tangential (shear) components of stress on a plane.	1 hr
1.3	Deformation, displacement, gradient of deformation and strains in elastic solids. Cartesian components of strain and Cauchy's strain-displacement relationships (small-strain only). Strain tensor in 2D and 3D. Write the stress tensor and strain tensor for Plane stress and Plane Strain analysis.	1 hr
1.4	Stress on an oblique plane under axial loading, Discuss principal planes, characteristic equation to find principal stresses for 2D and 3D state of stress, stress invariants. Evaluate principal stresses in 2D and 3D using characteristic equations.	2 hrs
1.5	Discuss the order of principal stress and maximum shear stress. Compare the principal stresses in 2D and 3D state of stress. Represent the state of stress using principal stress tensor. Determine the direction of principal stresses as eigenvectors of the principal stress tensor.	2 hrs
1.6	Represent the 2D and 3D state of stress using principal stress graphically (Mohr's circle). Determine the maximum shear stress by Mohr's circle method and compare with the theoretical relations.	2 hrs
2	Module 2: Strain measurements	8 hrs
2.1	Strain gauges and stress gauges, Different types of strain gauges – construction and working, Different application of strain gauges. Variable resistance strain gauge	2 hr
2.2	Gauge characteristics, gauge sensitivity, measurement of static and dynamic strain, and measurement of strain over a long period at high and low temperature.	2 hrs
2.3	Strain rosette - Rectangular rosettes and Delta rosettes (simple problems).	2 hrs
2.4	Residual stresses, harmful effects of residual stresses, beneficial effects of residual stresses.	2 hrs
3	Module 3 :Instrumentation	9 hrs
3.1	Strain circuits, potentiometer circuits, Range and sensitivity, The wheatstones bridge.	2 hrs
3.2	Principles of measurements: Error, Accuracy and precision,	1 hr

	Uncertainty analysis, Curve fitting.	
3.3	Oscillograph ,cathode ray oscilloscope,	1 hr
3.4	Transducer – Characteristics and properties.	1 hr
3.5	Displacement transducer – Construction and working, Pressure transducer - Construction and working.	2 hrs
3.6	Velocity transducer - Construction and working	1 hr
3.7	Acceleration transducer - Construction and working.	1 hr
4	Module 4 : Photoelasticity.	8 hrs
4.1	The polariscope, Stress optic law, Polariscope arrangements – Plane polariscope and Circular Polariscope.	2 hrs
4.2	Dark field and light field , isochromatics and isoclinics , Use of photoelastic coatings.	2 hrs
4.3	Different types of compensation techniques.	2 hrs
4.4	Coating stresses, Failure theories, steps in brittle coating tests.	2 hr
5	Module 5 :Non Destructive Methods.	8 hrs
5.1	Non Destructive testing Methods – Types – dye penetrant methods, Radiography – X – ray and Gamma ray.	2 hrs
5.2	X – ray fluoroscopy , Penetrameter (Detailed description)	2 hr
5.3	Magnetic particle methods, advantages and disadvantages, applications.	2 hrs
5.4	Introduction to lasers in NDT – Ultrasonic flaw detection.	2 hrs



CODE	COURSE NAME	CATEGORY	L	T	P	CREDIT
MET395	ADVANCED THERMODYNAMICS	VAC	3	1	0	4

Preamble: This course involves the application of principles studied in thermodynamics for analysis of thermal energy systems. This course also covers the properties of pure substances, Energy balance of reacting systems and advances in chemical thermodynamics.

Course Outcomes: After the completion of the course the student will be able to

CO 1	Apply the concepts of basic thermodynamics, entropy and energy for analyses of thermal energy systems.
CO 2	Understand properties of pure substance and thermodynamic properties of real gases
CO 3	Apply energy balances to reacting systems for both closed and open system.
CO 4	Define the chemical equilibrium constant and apply the general criteria for chemical equilibrium analysis to reacting ideal-gas mixtures.

Mapping of course outcomes with program outcomes

	PO 1	PO 2	PO 3	PO 4	PO 5	PO 6	PO 7	PO 8	PO 9	PO 10	PO 11	PO 12
CO 1	3	3	2									
CO 2	3	3	2									
CO 3	3	3	2									
CO 4	3	3	2									

Assessment Pattern

Bloom's Category	Continuous Assessment Tests		End Semester Examination
	1	2	
Remember	10	10	10
Understand	10	10	20
Apply	20	20	50
Analyse	10	10	20
Evaluate			
Create			

Mark distribution

Total Marks	CIE	ESE	ESE Duration
150	50	100	3 hours

Continuous Internal Evaluation Pattern:

Attendance	: 10 marks
Continuous Assessment Test (2 numbers)	: 25 marks
Assignment/Quiz/Course project	: 15 marks

End Semester Examination Pattern: There will be two parts; Part A and Part B. Part A contain 10 questions with 2 questions from each module, having 3 marks for each question. Students should answer all questions. Part B contains 2 questions from each module of which student should answer any one. Each question can have maximum 2 sub-divisions and carry 14 marks.

Course Level Assessment Questions**Course Outcome 1 (CO1):**

1. One kg of water at 273 K is brought into contact with a heat reservoir at 373 K. When the water has reached 373 K, find the entropy change of water, of the heat reservoir and of the universe.
2. State and prove Clausius Theorem
3. Water at 363 K flowing at the rate of 2 kg/s mixes adiabatically with another stream of water at 303 K flowing at the rate of 1 kg/s. Estimate the entropy generation rate and rate of exergy loss due to mixing. Take $T_0 = 300$ K

Course Outcome 2 (CO2)

1. A large insulated vessel is divided into two chambers one containing 5 kg of dry saturated steam at 0.2 MPa and the other 10 Kg of steam 0.8 quality at 0.5 MPa. If the partition between the chambers is removed and the steam is mixed thoroughly and allowed to settle, find the final pressure, steam quality and entropy change in the process
2. Draw the phase equilibrium diagram for a pure substance on h-s plot with relevant constant property lines.
3. Show that for an ideal gas the slope of the constant volume line on the T-S diagram is more than that of the constant pressure line.

Course Outcome 3(CO3):

1. Determine the adiabatic flame temperature when liquid octane at 298 K is burned with 300% theoretical air at 298 K in a steady flow process
2. What is heat of reaction? When is it positive and when negative?

3. Calculate the degree of ionization of cesium vapour at 10^{-6} atm at the two temperatures of 2260 and 2520 K

Course Outcome 4 (CO4):

1. Explain law of mass action
2. Explain reaction equilibrium constant.
3. Discuss second law analysis of reactive systems

MODEL QUESTION PAPER

APJ ABDUL KALAM TECHNOLOGICAL UNIVERSITY

V SEMESTER BTECH DEGREE EXAMINATION

MET395: ADVANCED THERMODYNAMICS

Maximum: 100Marks

Duration:3 hours

PART A

Answer all questions, each question carries 3 marks

1. Show that entropy is a property of the system
2. What is the meaning of quality of energy
3. Draw the phase equilibrium diagram for a pure substance on T-s plot with relevant constant property lines.
4. Write Clausius – Clapeyron equations
5. Explain law of corresponding states
6. Explain Wander-Walls equation of state
7. Explain Second-Law Analysis of Reacting systems
8. What do you meant by adiabatic flame temperature?
9. Explain law of mass action
10. What is van't Hoff equation

(10×3=30Marks)

PART B

Answer one full question from each module

MODULE 1

11. Three identical finite bodies of constant heat capacity are at temperatures 300, 300 and 100 K. If no work or heat is supplied from outside, what is the highest temperature to which any one of the bodies can be raised by the operation of heat engines or refrigerators (14 marks)

12. A pressure vessel has a volume of 1m^3 and contains air at 1.4 MPa, 448K. The air is cooled to 298K by heat transfer to surroundings at 298 K. Calculate the availability in the initial and final states and irreversibility of the process. Take $P_0 = 100\text{kPa}$ (14 marks)

MODULE 2

13. Steam initially at 0.3 MPa, 523K is cooled at constant volume. Find

a) Temperature at which steam become saturated vapour,

b) What is the quality at 353 K,

c) What is the heat transferred per kg of steam in cooling from 523 K to 353 K

(14 marks)

14. Derive Maxwell relations and TdS equations

(14 marks)

MODULE 3

15. a) What are virial coefficients ? When do they become zero?

(7 Marks)

b) Express Vander – Walls constants in terms of critical properties

(7 marks)

16. Calculate the volume of 2.5 Kg moles of steam at 236.4 atm. And 776.76 K with the help of compressibility factor vs reduced pressure graph. At this given volume and pressure what would be the temperature in K, if steam behaves like a Vander-Walls gas. The critical pressure, volume and temperature of steam are 218.2 atm, $57\text{ cm}^3/\text{g}$ mole and 647.3 K respectively.

(14 marks)

MODULE 4

17. a) Explain second law efficiency of a reactive system ? (4 marks)

b) Explain first law analysis of reactive systems. (10 Marks)

18. The products of combustion of an unknown hydrocarbon C_xH_y have the following composition as measured by an Orsat apparatus

CO_2 8%, CO 0.9%, O_2 8.8% and N_2 82.3 % Find a) Composition fuel b) air-fuel ratio and c) percentage of excess air used. (14 marks)

MODULE 5

19. a) What is Gibbs function of formation (5 marks)

b) Explain the phase equilibrium for a single component system (9 marks)

20. a) What is degree of reaction (5 marks)

b) Explain the phase equilibrium for a multi component system (9 marks)

Syllabus

Module 1

RECAPITULATION OF FUNDAMENTALS. Basic definition and concepts; The basic laws of Thermodynamics, Entropy flow and entropy production, 3rd law of Thermodynamics, Availability in steady flow open system and in a closed system, Irreversibility and effectiveness.

Module 2

PROPERTIES OF PURE SUBSTANCES. P-V-T surfaces, phase diagram, phase changes, various properties diagram, 1st order phase transition and 2nd order phase transition, Clapeyron's equation, Ehrenfest's equations, Maxwell's equations, equation for internal energy, enthalpy, entropy, specific heat and Joule Thompson coefficient.

Module 3

EQUATION OF STATE FOR REAL GASES. Compressibility factor and generalised compressibility chart, Law of corresponding state, law of pseudo critical pressure and temperature, reduced coordinate, Vander-Waals equation of state and other equation of state.

Module 4

CHEMICAL REACTION. Fuels and Combustion, First-Law Analysis of Reacting Systems: Steady-Flow Systems and Closed Systems, Entropy Change of Reacting Systems, Second-Law Analysis of Reacting systems.

Module 5

CHEMICAL THERMODYNAMICS. Gibb's theorem, Gibbs function of mixture of inert ideal gases, Chemical equilibrium, Thermodynamic equation for phase, Degree of reaction, equation of reaction, law of mass action, heat of reaction and Vant Hoff Isober, Phase Equilibrium for a Single-Component System and Multi-Component System

Text books:

1. Richard Edwin Sonntag , G.J. Van Wylen, Introduction to Thermodynamics- Classical and Statistical Wiley , 1991
2. Cengel and Boles., Thermodynamics : An engineering Approach McGraw-Hill, 2007 Sixth Edition
3. P.K. Nag. Engineering Thermodynamics Tata McGraw -Hill , 2013

Reference books:

1. M. Zemansky, R H Dittman. Heat and Thermodynamics –7th Edition 1998
2. E. F . Obert, Concepts of thermodynamics – McGraw-Hill, 1963

Course Contents and Lecture Schedule

No	Topic	No. of Lectures
1		
1.1	Basic definition and concepts; The basic laws of Thermodynamics,	3
1.2	Entropy flow and entropy production, 3rd law of Thermodynamics,	2
1.3	Availability in steady flow open system and in a closed system	2
1.4	Irreversibility and effectiveness.	2
2		
2.1	PROPERTIES OF PURE SUBSTANCES. P-V-T surfaces, phase diagram, phase changes, various properties diagram,	3
2.2	1st order phase transition and 2nd order phase transition, Clapeyron's equation, Ehrenfest's equations,	3
2.3	Maxwell's equations, equation for internal energy, enthalpy, entropy, specific heat and joule Thompson coefficient.	3
3		
3.1	EQUATION OF STATE FOR REAL GASES. Compressibility factor and generalised compressibility chart,	2
3.2	Law of corresponding state	2
3.3	law of pseudo critical pressure and temperature	3
3.4	Reduced coordinate, Wander-Walls equation of state and other equation of state.	2
4		
4.1	CHEMICAL REACTION. Fuels and Combustion,	1
4.2	First-Law Analysis of Reacting Systems: Steady-Flow Systems and Closed Systems	3
4.3	Entropy Change of Reacting Systems	2
4.4	Second-Law Analysis of Reacting systems	3
5		
5.1	CHEMICAL THERMODYNAMICS. Gibb's theorem, Gibbs function of mixture of inert ideal gases,	2
5.2	Chemical equilibrium, Thermodynamic equation for phase,	2
5.3	Degree of reaction, equation of reaction, law of mass action,	2
5.4	Heat of reaction and Vant Hoff Isober, Phase Equilibrium for a Single-Component System and Multi-Component System	3

CODE	COURSENAME	CATEGORY	L-T-P	CREDITS
MET 397	FLUID POWER AUTOMATION	VAC	3-1-0	4

Preamble :

This course provides basic ideas of fluid power automation. It enables the students to design and optimize pneumatic and hydraulic automation systems.

Prerequisite : Nil**Course Outcomes :**

After completion of the course the student will be able to

CO1	Explain the concept of power generating elements
CO2	Describe fundamentals of actuator and accumulator
CO3	Explain in detail control and regulation elements
CO4	Illustrate different circuit design methods
CO5	Illustrate electrical control of pneumatic and hydraulics circuits

Mapping of course outcomes with program outcomes

	PO1	PO2	PO3	PO4	PO5	PO6	PO7	PO8	PO9	PO10	PO11	PO12
CO1	3	2	1									
CO2	3	2										
CO3	3	2	1									
CO4	3	1										
CO5	3	1										

Assessment Pattern

Bloom Category	Continuous Assessment Tests		End Semester Examination
	1	2	
Remember	10	10	10
Understand	20	20	20
Apply	20	20	70
Analyse			
Evaluate			
Create			

Mark Distribution and duration of ESE

Total Marks	CA	ESE	ESE Duration
150	50	100	3 Hours

Continuous Internal Evaluation Pattern

Attendance : 10 marks

Continuous Assessment Test (2 numbers) : 25 marks

Assignment/Quiz/Course project : 15 marks

End semester pattern:

There will be two parts; Part A and Part B. Part A contain 10 questions with 2 questions from each module, having 3 marks for each question. Students should answer all questions. Part B contains 2 questions from each module of which student should answer any one. Each question can have maximum 2 sub-divisions and carry 14 marks.

Course Level Assessment Questions:**Course Outcome 1 (CO1):**

1. Explain the need and benefits of automation.
2. Discuss the various components of a fluid power system.
3. Discuss about the hydraulic and pneumatic element selection criteria based with respect to a typical example.

Course Outcome 2 (CO2):

1. Write a detailed note on Linear Actuators.
2. Give a short notes on (a) Spring Return Single acting Cylinder and (b) Double acting cylinder with a piston rod on both sides
3. Make a circuit sketch showing the use of accumulators as a shock absorber.

Course Outcome 3 (CO3):

1. Explain different types of direction and flow control valves.
2. Explain the components of closed loop hydraulic systems with a block diagram.
3. With a neat sketch, describe the construction and working of pressure compensated flow control valve.

Course Outcome 4 (CO4):

1. Construct a ladder diagram for a hydraulic circuit with six cylinders used to control industrial robot.
2. Describe combinational and sequential logical circuits.
3. Design and develop a hydraulic circuit for the following sequence using cascade method. A+ B+ C+

Course Outcome 5 (CO5):

1. Explain basic electrical devices used in electro pneumatic circuits.
2. Explain the functions of relays, timers and counters in hydraulic and pneumatic circuits.
3. Explain the basic structure of a PLC.

MODEL QUESTION PAPER
APJ ABDUL KALAM TECHNOLOGICAL UNIVERSITY
V SEMESTER B.TECH DEGREE EXAMINATION
MET397: FLUID POWER AUTOMATION

Maximum: 100 Marks

Duration: 3 hours

PART A

Answer all questions, each question carries 3 marks

1. What are the limitations of fluid power automation?
2. What are the factors to be considered in the selection of pump?
3. Define spool valve?
4. How is counter represented in ladder diagram?
5. What is a linear actuator?
6. What is the function Karnaugh map?
7. Define underlap and overlap in the context of servo valve spools?
8. What are the uses of relays in hydraulic and pneumatic circuits?
9. What is the function of intensifier?
10. List the components of PLC. (10 X 3 = 30 marks)

PART B

Answer one full question from each module

Module 1

11. Describe in brief with neat sketches any 16 ISO symbols used for fluid power elements. (14 marks)
12. Briefly explain the working and construction details of Vane pump with a diagram (14 marks)

Module 2

13. Describe the working principle of hydraulic accumulators (14 marks)
14. With a neat sketch, explain the end cushion provided in hydraulic cylinder (14 marks)

Module 3

15. Draw a neat sketch and explain the working of pressure and temperature compensated flow control valve (14 marks)
16. Write short notes on direction control valves and its types with neat sketches (14 marks)

Module 4

17. Draw and explain the working principle of fail-safe circuit with overload protection (14 marks)
18. Design and draw a hydraulic circuit for A+B+B+A+ sequencing operation and explain. (14marks)

Module 5

19. Design and draw electro hydraulic circuit for hydraulic motor braking system (14 marks)

20. a) Draw the fluid power symbols of any 4 accessories (4 marks)

b) Describe the advantages and disadvantages of fluid power systems

(10 marks)

Syllabus

Module 1

Need for automation, classification of drives- hydraulic and pneumatic –comparison ISO symbols for fluid power elements, selection criteria Fluid power generating elements-hydraulic pumps and motorgears, vane, piston pumps-motors-selection and specification

Module 2

Drive characteristics- linear actuator–types, mounting details, cushioning–power packs–accumulators

Module 3

Control and regulation elements–direction, flow and pressure control valves-methods of actuation, types, sizing of ports. Spool valves- operating characteristics, electro hydraulic servo valves-different types-characteristics and performance

Module 4

Typical design methods –ladder diagram- sequencing circuits design - combinational logic circuit design-cascade method - Karnaugh map method.

Module 5

Electrical control of pneumatic and hydraulic circuits- use of relays, timers, counters, interfacing with PLCs, proportional control of hydraulic systems

Text Books:

1. Alavudeen A, Fluid Power Transmission and Control, Charotar Publishing House, 2007
2. Jagadeesha T, Hydraulics and Pneumatics, I K International Publishing House, 2015
3. AntonyEsposito,FluidPowerSystemsandcontrol,Prentice-Hall,1988

Reference Books:

1. PeterRohner,FluidPowerlogiccircuitdesign, MacmillanPress, 1994.
2. E.C.FitchandJ.B.Surjaatmadja.Introductiontofluidlogic,McGrawHill, 1978
3. HerbertE.Merritt,Hydrauliccontrolsystems,JohnWiley&Sons,1967
4. Dudley.A.Pease,BasicFluidPower,PrenticeHall,1967

Course Contents and Lecture Schedule

No.	Topic	No. of Lectures
I	Need for automation, classification of drives- hydraulic and pneumatic – comparison, ISO symbols for fluid power elements, selection criteria	4
	Fluid power generating elements – hydraulic pumps and motorgears, vane, piston pumps-motors- selection and specification	5
II	Drive characteristics- linear actuator–types, mounting details, cushioning–power packs–accumulators	9
III	Control and regulation elements–direction, flow and pressure control valves- methods of actuation, types, sizing of ports, spool valves-operating characteristics, Electro hydraulic servo valves-different types-characteristics and performance	10
IV	Typical design methods –Ladder diagram- sequencing circuits design - combinational logic circuit design-cascade method – Karnaugh map method.	9
V	Electrical control of pneumatic and hydraulic circuits- use of relays, timers, counters ,interfacing with PLCs, proportional control of hydraulic systems	8



APJ ABDUL KALAM
TECHNOLOGICAL
UNIVERSITY

SEMESTER VI

KTU



CODE	COURSE NAME	CATEGORY	L	T	P	CREDIT
MET302	HEAT & MASS TRANSFER	PCC	3	1	0	4

Preamble:

The objectives of the course are:

- To introduce the various modes of heat transfer and to develop methodologies for solving a wide variety of practical heat transfer problems
- To provide useful information concerning the performance and design of simple heat transfer systems
- Conceive the energy balance in any thermal practical situation involving heat transfer mechanisms.
- To introduce mass transfer.

Prerequisite: MET203 Mechanics of Fluids, MET202 Engineering Thermodynamics

Course Outcomes: After the completion of the course the student will be able to

CO 1	Apply principles of heat and mass transfer to engineering problems
CO 2	Analyse and obtain solutions to problems involving various modes of heat transfer
CO 3	Design heat transfer systems such as heat exchangers, fins, radiation shields etc.
CO 4	Define laminar and turbulent boundary layers and ability to formulate energy equation in flow systems.

Mapping of course outcomes with program outcomes

	PO 1	PO 2	PO 3	PO 4	PO 5	PO 6	PO 7	PO 8	PO 9	PO 10	PO 11	PO 12
CO 1	3	3	2									1
CO 2	3	3	3									2
CO 3	3	3	3									2
CO 4	3	3	3									2

Assessment Pattern

Bloom's Category	Continuous Assessment Tests		End Semester Examination
	1	2	
Remember	10	10	10
Understand	20	10	20
Apply	10	20	50
Analyse	10	10	20
Evaluate			
Create			

Mark distribution

Total Marks	CIE	ESE	ESE Duration
150	50	100	3 hours

Continuous Internal Evaluation Pattern:

Attendance	: 10marks
Continuous Assessment Test(2numbers)	: 25 marks
Assignment/Quiz/Course project	: 15marks

End Semester Examination Pattern: There will be two parts; Part A and Part B. Part A contain 10 questions with 2 questions from each module, having 3 marks for each question. Students should answer all questions. Part B contains 2 questions from each module of which student should answer any one. Each question can have maximum 2 sub-divisions and carry 14 marks.

Course Level Assessment Questions**Course Outcome 1 (CO1):**

1. A furnace wall is made up of three layers of thicknesses 250 mm, 100 mm and 150 mm with thermal conductivities of 1.65 W/m.K and 9.2 W/m.K respectively. The inside is exposed to gases at 1250 °C with a convection coefficient of 25 W/m².K. and the inside surface is at 1100 °C, the outside surface is exposed to air at 25 °C with convection coefficient of 12 W/m².K. Determine (a) the unknown thermal conductivity K (b) the overall heat transfer coefficient (c) all the intermediate temperatures?
2. Derive an expression for steady state temperature distribution in a slab with internal heat generation.
3. Dry air at 300 °C and 1 atm flows over a wet flat plate 600 mm. long at a velocity of 50 m/s. Calculate the mass transfer co-efficient of water vapour in air at the end of the plate. Take the diffusion co-efficient of water vapour in air, $D = 0.26 \times 10^{-4} \text{ m}^2/\text{s}$.

Course Outcome 2 (CO2)

1. Discuss the importance of non-dimensional numbers in heat transfer problems.
2. A hollow sphere ($k = 65 \text{ W/m.K}$) of 120 mm inner diameter and 350 mm outer diameter is covered 10 mm layer of insulation ($k = 10 \text{ W/m.K}$). The inside and outside temperatures are 500 °C and 50 °C respectively. Calculate the rate of heat flow through this sphere.

3. A steel ball (specific heat =0.46 kJ/kg.K, and thermal conductivity 35W/m.K) having 5 cm diameter and initially at a uniform temperature of 450 °C is suddenly placed in a control environment in which the temperature is maintained at 100 °C. Calculate the time required for the ball to attain a temperature of 150 °C.

Course Outcome 3(CO3):

1. Water at the rate of 4 kg/s is heated from 40 °C to 55°C in a shell and tube heat exchanger. On the shell side one pass is used with water as the heating fluid and at a mass flow rate of 2 kg/s, and entering the heat exchanger at 95 °C. The overall heat transfer coefficient is 1500 W/m²K. and the average water velocity in the 2 cm diameter tubes is 0.5 m/s. Because of space limitations, the tube length must not exceed 3 m. Calculate the number of tube passes, the number of tubes per pass and the length of the tubes, keeping in mind the design constraints.
2. Two large plates, one at 800 K and other at 600 K have emissivities 0.5 and 0.8 respectively. A radiation shield having an emissivity 0.1 on one side and emissivity 0.05 on the other side is placed between the plates. Calculate the heat transfer by radiation per square meter with and without the radiation shield.
3. A rectangular aluminum fin of thermal conductivity 200 W/m.K, 3mm. thick and 7.5 cm long protrudes out from a wall. The fin base is maintained at a temperature of 300 °C and the ambient temperature is 50 °C with heat transfer coefficient 10W/m²K. The tip of the fin is insulated. Calculate the heat transfer from the fin per unit depth of material.

Course Outcome 4 (CO4):

1. Explain velocity boundary layer and thermal boundary layer with neat sketches.
2. Air at 40 °C flows over a tube with a velocity of 30 m/s. The tube surface temperature is 120 °C. Calculate the heat transfer coefficient for the following cases:
 - (i) Tube is square with a side of 6 cm
 - (ii) Tube is circular cylinder with a diameter of 6 cm.
3. Air at 20 °C at atmospheric pressure flows over a flat plate at a velocity of 3 m/s. If the plate is 1 m wide and at 80 °C, calculate the following at $x = 300\text{mm}$.
 - i. Hydrodynamic boundary layer thickness
 - ii. Thermal boundary layer thickness
 - iii. Local friction coefficient
 - iv. Average heat transfer coefficient
 - v. Heat transfer rate

MODEL QUESTION PAPER

APJ ABDUL KALAM TECHNOLOGICAL UNIVERSITY

SIXTH SEMESTER MECHANICAL ENGINEERING

Heat and Mass Transfer-MET302

Maximum:100Marks

Duration: 3 hours

PART A

Answer all questions. Each question carries 3 marks

1. Discuss about the application of Heisler chart and Schmidt plot in heat transfer analysis.
2. How does a numerical solution method differ from analytical one? Explain.
3. What are the characteristics of a boundary layer?
4. Write the significance of Nusselt number.
5. What is meant by condensation heat transfer? How it differs from drop wise heat transfer?
6. What are the main factors to be considered for a heat exchanger design?
7. Explain about radiation shape factor.
8. What are the properties of blackbody?
9. Give two examples of mass transfer in day-to-day life.
10. Explain Ficks law of diffusion with suitable assumptions.

(10 X 3 = 30 Marks)

PART B**Answer one full question from each module****MODULE 1**

11.

a) Derive 3-dimensional unsteady state heat conduction equation with heat generation, in Cartesian co-ordinate system for anisotropic material. (7Marks)

b) A 3 mm diameter and 5m long electric wire is tightly wrapped with a 2 mm thick plastic cover whose thermal conductivity is $k = 0.15 \text{ W/m-K}$. Electrical measurements indicate that a current of 10 A passes through the wire and there is a voltage drop of 8 V along the wire. If the insulated wire is exposed to a medium at $T_\infty = 30^\circ\text{C}$ with a heat transfer coefficient of $h = 12 \text{ W/m}^2\text{-K}$, determine the temperature at the interface of the wire and the plastic cover in steady operation. Also state with reason, whether doubling the thickness of the plastic cover will increase or decrease heat transfer.

(7 Marks)

12.

a) Derive an expression for temperature distribution for 1-dimensional slab with varying thermal conductivity. Assume the variation of thermal conductivity of slab as $k = k_0(1+\beta t)$.

(7 Marks)

b) A square plate heater 15 cm x 15 cm is inserted between two slabs. Slab A is 2 cm thick ($k = 50\text{W/m-K}$) and Slab B is 1cm thick ($k = 0.2\text{W/m-K}$). The outside heat transfer coefficients on side A and side B are $200\text{W/m}^2\text{-K}$ and $50\text{W/m}^2\text{-K}$ respectively. The temperature of surrounding air is 25°C . If rating of heater is 1 KW, find (a) Maximum temperature in the system, and (b) outer surface temperature of the two slabs. (7Marks)

MODULE II

13.

a) Saturated propane at 300 K with a velocity of 25 cm/s flows over a flat plate of length $L=2 \text{ m}$. and width $w=1 \text{ m}$. maintained at uniform temperature of 400 K. Calculate the local heat transfer coefficient at 1 m. length and the average heat transfer coefficient from $L=0 \text{ m}$. to $L=2 \text{ m}$. Also find the heat transfer. (7Marks)

b) Hot air at atmospheric pressure and 80°C enters an 8 m. long uninsulated square duct of cross section 0.2 m. x 0.2 m. that passes through the attic of a house at a rate of $0.15\text{m}^3/\text{s}$. The duct is observed to be nearly isothermal at 60°C . Determine the exit temperature of the air. (7Marks)

14.

a) Air at 15°C , 35 m/s , flows through a hollow cylinder of 4 cm inner diameter and 6 cm outer diameter and leaves at 45°C . The tube passes through a room where the room temperature is 65°C and tube wall is maintained at 60°C . Calculate the heat transfer coefficient between the air and the inner tube. (7Marks)

b) Consider a $0.6\text{ m} \times 0.6\text{ m}$ thin square plate in a room at 30°C . One side of the plate is maintained at a temperature of 90°C , while the other side is insulated. Determine the rate of heat transfer from the plate by natural convection. If the emissivity of the surface is 1.0 , calculate the heat loss by radiation. Also calculate the percentage of heat loss by convection. (7Marks)

MODULE III

15.

a) A counter flow double pipe heat exchanger is to heat water from 20°C to 80°C at a rate of 1.2 kg/s . The heating is to be accomplished by geothermal water available at 170°C at a mass flow rate of 2 kg/s . The inner tube is thin walled and has a diameter of 1.5 cm . If the overall heat transfer coefficient of the heat exchanger is $640\text{ W/m}^2\text{-K}$, determine the length of the heat exchanger required to achieve the desired heating. Use $\epsilon\text{-NTU}$ method.

(8 Marks)

b) Derive an expression for LMTD of double pipe, parallel flow heat exchanger.

(6 Marks)

16.

a) Steam in the condenser of a power plant is to be condensed at a temperature of 30°C with cooling water from a nearby lake, which enters the tubes of the condenser at 14°C and leaves at 22°C . The surface area of the tubes is 45 m^2 and the overall heat transfer coefficient is $2100\text{ W/m}^2 \cdot ^{\circ}\text{C}$. Determine the mass flow rate of the cooling water needed and the rate of condensation of the steam in the condenser. (7Marks)

b) In a double pipe heat exchanger, hot fluid with a specific heat of 2300 J/kg enters at 380°C and leaves at 300°C . Cold fluid enters at 25°C and leaves at 210°C . Calculate the heat exchanger area required for (i) Counter flow and (ii) Parallel flow. Take overall heat transfer coefficient as $750\text{ W/m}^2\text{ K}$ and mass flow rate of hot fluid is 1 kg/s . (7Marks)

MODULE IV

17.

a) A 70 mm. thick metal plate with a circular hole of 35 mm. diameter along the thickness is maintained at a uniform temperature 250 °C. Find the loss of energy to the surroundings at 27 °C, assuming the two ends of the hole to be as parallel discs and the metallic surfaces and surroundings have blackbody characteristics. (6Marks)

b) Two large parallel planes with emissivities of 0.3 and 0.5 are maintained at temperatures of 527 °C and 127 °C respectively. A radiation shield having emissivities of 0.05 on both sides is placed between them. Calculate,

(i) Heat transfer rate between them without shield.

(ii) Heat transfer rate between them with shield.

(8 Marks)

18.

a) Two parallel plates of size 1.0 m. by 1.0 m. spaced 0.5 m apart are located in a very large room, the walls of which are maintained at a temperature of 27°C. One plate is maintained at a temperature of 900 °C and the other at 400 °C. Their emissivities are 0.2 and 0.5 respectively. If the plates exchange heat between themselves and the surroundings, find the net heat transfer to each plate and to the room. Consider only the plate surface facing each other.

(8 Marks)

b) Two rectangular surfaces are perpendicular to each other with a common edge of 2 m. The horizontal plane is 2 m. long and vertical plane is 3 m long. Vertical plane is at 1200 K and has an emissivity of 0.4. the horizontal plane is 18 °C and has an emissivity of 0.3. Determine the net heat exchange between the planes. (6 marks)

MODULE V

19.

a) Explain the analogy between heat and mass transfer.

(6 Marks)

b) Dry air at 30°C and 1 atm flows over a wet flat plate 600 mm. long at a velocity of 50 m/s. Calculate the mass transfer co-efficient of water vapour in air at the end of the plate. Take the diffusion co-efficient of water vapour in air, $D = 0.26 \times 10^{-4} \text{ m}^2/\text{s}$.

(8Marks)

20.

a) Gaseous hydrogen is stored at elevated pressure in a rectangular steel container of 10 mm. wall thickness. The molar concentration of hydrogen in steel at the inner surface is 2 kg mol/m^3 , while the concentration of hydrogen in steel at the outer surface is 0.5 kg mol/m^3 . The binary diffusion coefficient for hydrogen in steel is $0.26 \times 10^{-12} \text{ m}^2/\text{s}$. What is the mass flux of hydrogen through the steel? (8 Marks)

b) Explain the phenomenon of equimolar counter diffusion. Derive an expression for equimolar counter diffusion between two gases or liquids.

(6 Marks)

Syllabus

Module 1-

CONDUCTION HEAT TRANSFER

Introduction to heat transfer- thermodynamics and heat transfer-typical heat transfer situations- modes of heat transfer- mechanism of heat transfer- basic laws of heat transfer- thermal conductivity-effect of temperature on thermal conductivity- combined heat transfer mechanism-real life situations of combined heat transfer.

Differential equations of heat conduction-boundary conditions and initial conditions, one dimensional steady state situations – plane wall, cylinder, sphere -concept of thermal resistance, critical radius, conduction with heat generation- Two-dimensional steady state situations, transient conduction, Lumped capacitance model, concept of Heisler chart and Schmidt Plot-Conduction shape factor-Numerical methods of analysis-thermal analysis of rectangular fins.

Module 2

CONVECTION HEAT TRANSFER

Fundamentals, order of magnitude analysis of momentum and energy equations; hydrodynamic and thermal boundary Layers-Relation between fluid friction and heat transfer-Concepts of fluid mechanics, Differential equation of heat convection, Laminar flow heat transfer in circular pipe – constant heat flux and constant wall temperature, thermal entrance region, Turbulent flow heat transfer in circular pipe, pipes of other cross sections, Heat transfer in laminar flow and turbulent flow over a flat plate, Reynolds analogy, Flow across a cylinder and sphere- Natural convection- basics-free convection heat transfer on a vertical flat plate-empirical relations for free convection heat transfer.

Module 3

HEAT EXCHANGERS

Condensation heat transfer phenomena- the condensation Number-Boiling heat transfer Phenomena-Simplified relations for boiling heat transfer-Introduction to heat exchangers-types of heat exchangers-the overall heat transfer coefficient-Fouling factor-LMTD analysis of heat exchangers-effectiveness-NTU method-Analysis of variable properties-compact heat exchangers-heat exchanger design considerations.

Module 4**RADIATION HEAT TRANSFER**

Physical mechanism of radiation heat transfer-Radiation properties-; Black body radiation Planck's law, Wein's displacement law, Stefan Boltzmann law, Kirchoff's law; Gray body Radiation shape factors-heat exchange between non -black bodies-Infinite parallel planes-Radiation combined with conduction and convection.

Module 5**MASS TRANSFER**

Introduction to mass transfer- Molecular diffusion in fluids- Steady state molecular diffusion in fluids under stagnant and laminar flow conditions - Fick's law of diffusion-Types of solid diffusion- mass transfer coefficients in laminar and turbulent flows- Introduction to mass transfer coefficient- Equimolar counter-diffusion- Correlation for convective mass transfer coefficient- Correlation of mass transfer coefficients for single cylinder- Theories of mass transfer- Overall mass transfer coefficients.

Text Books

1. Sachdeva R.C., Fundamentals of Engineering Heat and Mass Transfer, New Age Science Limited, 2009
2. R.K.Rajput. Heat and mass transfer, S.Chand &Co., 2015
3. Nag P.K., Heat and Mass Transfer, McGrawHill, 2011
4. Kothandaraman C.P., Fundamentals of Heat and Mass Transfer, New Age International, New Delhi,2006

Data Book

Heat and Mass Transfer data book: C.P. Kothandaraman, S. Subramanya, New age International Publishers,2014

Reference Books

2. Holman J.P, "Heat transfer", Mc Graw-Hill, 10th. Ed.,2009.
3. Yunus A. Cengel, "Heat and Mass Transfer: Fundamentals and Applications" McGraw-Hill Higher Education; 6th edition,2019.
4. Frank P. Incropera and David P. Dewitt, Heat and Mass Transfer, John Wiley and sons,2011

COURSE PLAN

MODULE	TOPICS	HOURS ALLOTTED
1	Introduction to heat transfer- thermodynamics and heat transfer-typical heat transfer situations- modes of heat transfer- mechanism of heat transfer- basic laws of heat transfer- thermal conductivity-thermal conductivity-effect of temperature on thermal conductivity-combined heat transfer mechanism-real life situations of combined heat transfer.	2-0-0
	Differential equations of heat conduction-boundary conditions and initial conditions, one dimensional steady state situations – plane wall, cylinder, sphere -concept of thermal resistance, critical radius, conduction with heat generation- Two-dimensional steady state situations, transient conduction, Lumped capacitance model, concept of Heisler chart and Schmidt Plot-Conduction shape factor-Numerical methods of analysis- thermal analysis of rectangular fins.	6-4-0
2	Fundamentals, order of magnitude analysis of momentum and energy equations; hydrodynamic and thermal boundary Layers-Relation between fluid friction and heat transfer-Concepts of fluid mechanics, Differential equation of heat convection, Laminar flow heat transfer in circular pipe – constant heat flux and constant wall temperature, thermal entrance region, Turbulent flow heat transfer in circular pipe, pipes of other cross sections, Heat transfer in laminar flow and turbulent flow over a flat plate, Reynolds analogy, Flow across a cylinder and sphere- Natural convection- basics- free convection heat transfer on a vertical flat plate- empirical relations for free convection heat transfer.	6-4-0
3	Condensation heat transfer phenomena- the condensation Number-Boiling heat transfer Phenomena-Simplified relations for boiling heat transfer-Introduction to heat exchangers-types of heat exchangers-the overall heat transfer coefficient-Fouling factor-LMTD analysis of heat exchangers-effectiveness-NTU method-Analysis of variable properties- compact heat exchangers-heat exchanger design considerations.	5-2-0
4	Physical mechanism of radiation heat transfer-Radiation properties-; Black body radiation Planck's law, Wein's displacement law, Stefan Boltzmann law, Kirchoff's law; Gray body Radiation shape factors-heat exchange between non -black bodies-Infinite parallel planes-Radiation combined with conduction and convection.	5-2-0

5	Introduction to mass transfer- Molecular diffusion in fluids- Steady state molecular diffusion in fluids under stagnant and laminar flow conditions - Fick's law of diffusion-Types of solid diffusion- mass transfer coefficients in laminar and turbulent flows- Introduction to mass transfer coefficient- Equimolar counter-diffusion- Correlation for convective mass transfer coefficient- Correlation of mass transfer coefficients for single cylinder- Theories of mass transfer- Overall mass transfer coefficients	7-2-0
---	---	-------

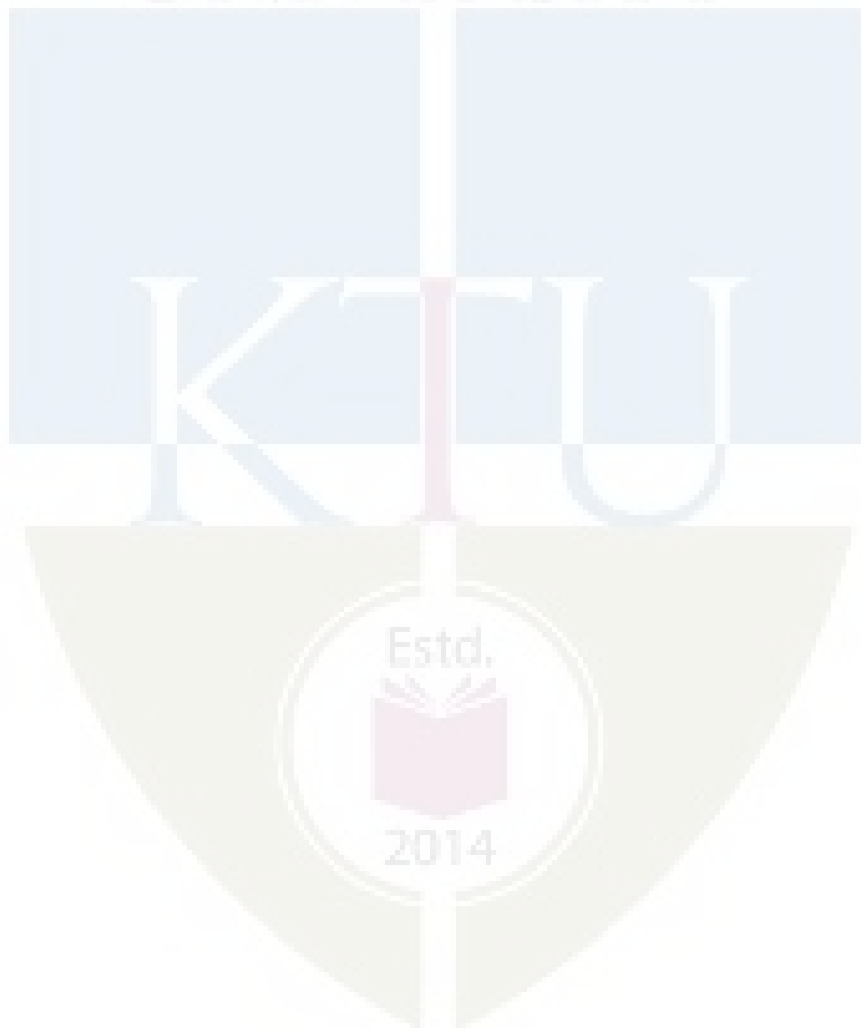

CODE MET304	COURSE NAME DYNAMICS AND DESIGN OF MACHINERY	CATEGORY	L	T	P	CREDIT
		PCC	3	1	0	4

Preamble: This course focuses on important topics of dynamics of machinery and design of machine elements. It covers the topics namely force of four bar mechanisms, design of flywheels, welded joints, riveted joints and spring. Design of machine elements due to impact, shock and fatigue loading are covered in the syllabus. Analysis of free and forced vibration of single degree of freedom systems and a brief introduction about free vibration of two degree of freedom systems is also included.

Prerequisite: EST100 Engineering Mechanics

Course Outcomes: After the completion of the course the student will be able to:

CO 1	Do engine force analysis and to draw turning moment diagrams
CO 2	Analyse free and forced vibrations of single degree of freedom systems
CO 3	Determine the natural frequencies of a two degree of freedom vibrating system and to calculate the stresses in a structural member due to combined loading
CO 4	Design machine elements subjected to fatigue loading and riveted joints
CO 5	Design welded joint and close coiled helical compression spring

Mapping of course outcomes with program outcomes

	PO 1	PO 2	PO 3	PO 4	PO 5	PO 6	PO 7	PO 8	PO 9	PO 10	PO 11	PO 12
CO 1	3	3	2									
CO 2	3	3	2									
CO 3	3	3	2									
CO 4	3	3	2									
CO 5	3	3	2									

Assessment Pattern

Bloom's Category	Continuous Assessment Tests		End Semester Examination
	1	2	
Remember	10	10	10
Understand	20	20	20
Apply	20	20	70
Analyse			
Evaluate			
Create			

Mark distribution

Total Marks	CIE	ESE	ESE Duration
150	50	100	3 hours

Continuous Internal Evaluation Pattern:

Attendance	: 10 marks
Continuous Assessment Test (2 numbers)	: 25 marks
Assignment/Quiz/Course project	: 15 marks

MECHANICAL ENGINEERING

End Semester Examination Pattern: There will be two parts; Part A and Part B. Part A contain 10 questions with 2 questions from each module, having 3 marks for each question. Students should answer all questions. Part B contains 2 questions from each module of which student should answer any one. Each question can have maximum 2 sub-divisions and carry 14 marks.

Course Level Assessment Questions

Course Outcome 1 (CO1):

1. Explain D' Alembert's principle.
2. Determine analytically the forces such as piston effort, force in the connecting rod and side thrust on the cylinder walls of a reciprocating engine.
3. Draw the turning moment diagram of IC engine.
4. Derive an expression for the coefficient of fluctuation of energy.
5. Derive an expression relating the stress in a flywheel and its linear speed.

Course Outcome 2 (CO2)

1. Explain the energy method and Newton's method to determine the natural frequencies of a single degree of freedom system.
2. Derive an expression for the logarithmic decrement.
3. Find the forced response of a damped single degree of freedom vibrating system subjected to a harmonic excitation.
4. Distinguish between motion transmissibility and force transmissibility.
5. What is whirling? Derive an expression for the critical speed of a shaft.

Course Outcome 3 (CO3):

1. Find the natural frequencies and mode shapes of a two degree freedom vibrating system.
2. What do you mean by eigenvalues and eigenvectors of a multi degree freedom vibrating system?
3. What are the steps in the design process?
4. Define stress concentration factor. How can we minimize it?

Course Outcome 4 (CO4):

1. Explain Goodman's criterion.

2. Explain Soderberg's criterion.
3. Define endurance limit and factor of safety.
4. Derive an expression for the impact stress due to a freely falling body.
5. Describe the modes of failure of a riveted joint.
6. What are the different efficiencies of a riveted joint?
7. Classify the riveted joints.

Course Outcome 5 (CO5):

1. What are the different types of welded joint?
2. Describe AWS welding symbols with neat sketches.
3. Determine the weld size of a joint subjected to axial, bending and twisting loads.
4. Derive an expression for the shear stress in the spring wire.
5. Derive an expression for the deflection of a helical compression spring.
6. Why concentric springs are required in certain applications?

MODEL QUESTION PAPER**APJ ABDUL KALAM TECHNOLOGICAL UNIVERSITY****VI SEMESTER BTECH DEGREE EXAMINATION****MET304 : DYNAMICS AND DESIGN OF MACHINERY**

Maximum: 100 Marks

Duration: 3 hours

*Use of Machine Design Data Book is permitted.***PART A**

Answer all questions, each question carries 3 marks

1. Describe briefly the dynamic force analysis of a reciprocating engine.
2. Derive an expression for the coefficient of fluctuation of energy.
3. Derive an expression for logarithmic decrement.
4. Define whirling speed of a shaft.
5. Explain the mode shapes of a vibrating system.
6. What are the steps in the design process?
7. Define endurance limit. What are the factors affecting it?
8. What are the failure modes of a riveted joint?

9. Describe the AWS welding symbols.

10. Explain i) surge ii) resilience and iii) curvature effect of a spring. (10×3=30 Marks)

PART B

Answer one full question from each module

MODULE 1

11. a) Describe with a neat sketch the turning moment diagram for a four-stroke internal combustion engine (4 marks)

b) The turning moment of an engine is given by the equation: $2500 + 750 \sin 3\theta$ Nm where θ is the crank angle in radians. The mean speed of the engine is 300 rpm. The flywheel along with other rotating parts attached to the engine have a mass of 500 kg at a radius of gyration of 0.8 m. Determine i) the power developed by the engine and ii) the percentage of fluctuation of speed of the flywheel (10 marks)

12. a) State and explain D' Alembert's principle. (4 marks)

b) The ratio of connecting rod length to crank length of a vertical gasoline engine is 4. The engine bore and stroke are 8 cm and 10 cm respectively. The mass of the reciprocating parts is 1 kg. The gas pressure on the piston is 6 bar, when it has moved 40° from the inner dead centre during the power stroke. Determine the following:

- i. Net load on the piston
- ii. Net load on the gudgeon pin and the crank pin
- iii. Thrust on the cylinder walls
- iv. Thrust on the crank bearing

The engine runs at 2000 rpm. At what engine speed will the net load on the gudgeon pin be zero? (10 marks)

MODULE 2

13. a) A machine of mass 1000 kg is acted upon by an external force of 2450 N at a speed of 1500 rpm. To reduce the effect, vibration isolators made of rubber having a static deflection of 2 mm under the machine load and an estimated damping factor of 0.2 are used. Determine the following:

- i. Force transmitted to the foundation

ii. Amplitude of vibration of machine

iii. Phase lag between the transmitted force and the displacement of mass.

(9 marks)

b) Distinguish between motion transmissibility and displacement transmissibility. (5 marks)

14. a) A damped spring mass system has mass 3 kg, stiffness 100 N/m and damping coefficient 3 Ns/m. Determine the following:

i. Damping ratio

ii. Damped natural frequency

iii. Logarithmic decrement

iv. Ratio of two successive amplitudes

(8 marks)

b) Describe briefly Newton's method and energy method used for obtaining the natural frequencies. (6 marks)

MODULE 3

15. Find the natural frequencies and mode shapes of a two degree freedom system shown in figure. The masses are $m_1 = m_2 = 10$ kg and the stiffness values are $k_1 = k_2 = 2$ kN/mm.

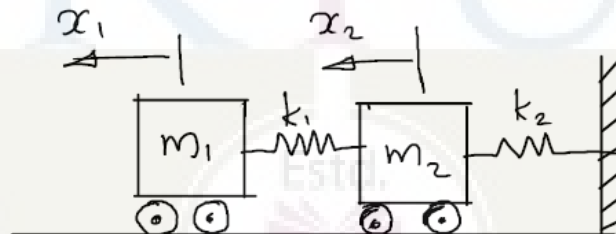

16. a) Define stress concentration factor. How can it be minimized? (5 marks)

b) Calculate the stress at point A on the fixed end of a rod of length 80 mm and cross-sectional area 30 mm^2 shown in figure. (9 marks)

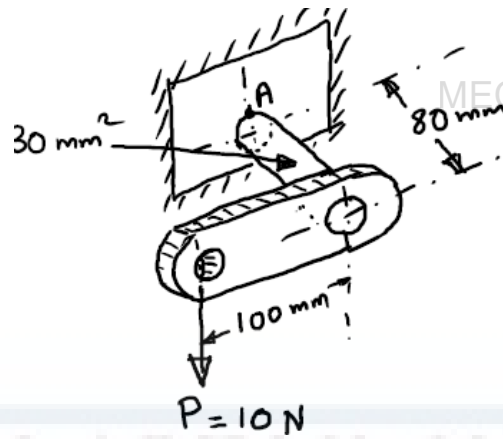

MODULE 4

17. a) Distinguish between Soderberg and Goodman criteria. (5 marks)

b) A round bar is subjected to the following variable loads. Torque varying from 2kNm to 5 kNm, bending moment varying from 10 kNm to 12 kNm. Calculate the size of the bar if it is made of C40 steel with yield stress of 324 MPa. Yield stress in shear is 50% of that in uniaxial loading. Adopt a factor of safety of 2.5 on yield stress for shear. (9 marks)

18. a) What are the advantages of riveted joint over welded joint? (4 marks)

b) Design a double riveted butt joint with equal widths of cover plates to join two plates of thickness 10 mm. The allowable stress for the material of the rivets and for the plates are as follows: For plate material in tension, $\sigma_t = 80$ MPa, for rivet material in compression, $\sigma_c = 120$ MPa, for rivet material in shear, $\tau = 60$ MPa (10 marks)

MODULE 5

19. a) Describe with neat sketches the different types of welded joints. (5 marks)

b) An eccentrically loaded bracket is welded to a support as shown in figure. The permissible shear stress for the weld material is 80 MPa. Determine the size of the weld. (9 marks)

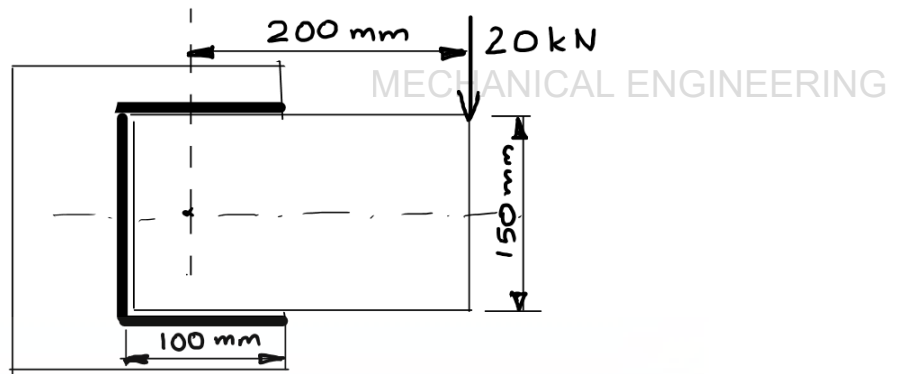

20. a) Derive an expression for the axial deflection of a close coiled helical spring.

(5 marks)

b) A bumper consisting of two helical springs of circular section, brings to rest a railway wagon of mass 1500 kg moving at 1.2 m/s. While doing so, the springs are compressed by 150 mm. The mean diameter of the coil is 6 times the wire diameter. The permissible shear stress is 400 MPa. Determine i) the maximum force on each spring ii) wire diameter of the spring, iii) mean diameter of the coils and iv) the number of active coils. Take $G=0.84 \times 10^6$ MPa.

(9 marks)

Syllabus

Module 1

Dynamic force analysis- D' Alembert's principle –four bar mechanism- engine force analysis (reciprocating engines)- piston side thrust-connecting rod force-piston effort- dynamic force analysis considering mass of the connecting rod-analytical method.

Flywheels-turning moment diagrams for four stroke internal combustion engine and multi cylinder engines-coefficient of fluctuation of speed-coefficient of fluctuation of energy-design of flywheels.

Module 2

Introduction- free vibration of single degree undamped systems- natural frequency-energy method- Newton's second law (free body diagram)-damped systems- logarithmic decrement.

Forced vibration-single degree of freedom systems-harmonic excitation-vibration isolation-transmissibility-whirling of shafts.

Module 3

Introduction to two degree of freedom systems- natural frequencies and mode shapes.

Introduction to design-definition, steps in the design process, materials and their properties-elastic and plastic behaviour of metals, ductile and brittle behaviour, shear, bending and torsional stresses, combined stresses, stress concentration factor.

Module 4

Shock and impact loads- fatigue loading- Gerber, Goodman and Soderberg criteria, endurance limit stress, factors affecting endurance limit, factor of safety.

Design of riveted joints- material for rivets, modes of failure, efficiency of joint, design of boiler and tank joints, structural joints.

Module 5

Design of welded joints-welding symbols, stresses in fillet and butt welds, Butt joint in tension, fillet weld in tension, fillet joint under torsion, fillet weld under bending, eccentrically loaded welds.

Springs- classification, spring materials, stresses and deflection of helical springs, axial loading, curvature effect, resilience, static and fatigue loading, surge in spring, critical frequency, concentric springs, end construction.

Text Books

1. Ballaney, P. L. Theory of machines and mechanisms. Khanna Publishers, 2010.
2. Rattan S S, Theory of Machines, Tata McGraw-Hill Education, 2005.
3. Bhandari V B, Design of Machine Elements, Tata McGraw-Hill Education, 2010.

Design Data Books (permitted for reference in the university examination)

1. Mahadevan, K., and K. Balaveera Reddy. Design Data Handbook; Mechanical Engineers in SI and Metric Units. CBS Publishers & Distributors, New Delhi, 2018.
2. NarayanaIyengar B.R & Lingaiah K, Machine Design Data Handbook, Tata McGraw Hill/Suma Publications, 1984
3. PSG Design Data, DPV Printers, Coimbatore, 2012

Reference Books

1. Charles E Wilson and J Peter Sadler, Kinematics and Dynamics of Machinery, Tata McGraw-Hill Education, 2008.
2. Amithabha Ghosh and Asok Kumar Malik, Theory of Mechanisms and Machines, East West Press, 2011
3. Robert L Norton, Design of Machinery, Tata Mc Graw-Hill, 2005
4. P C Sharma and D K Aggarwal, Machine Design, S K Kataria & Sons

Course Contents and Lecture Schedule

No	Topic	No. of Lectures
1		
1.1	Dynamic force analysis- D' Alembert's principle –Four bar mechanism-	3
1.2	Engine force analysis (reciprocating engines)- piston side thrust-connecting rod force-piston effort- dynamic force analysis considering mass of the connecting rod-analytical method.	4
1.3	Flywheels, turning moment diagrams-four stroke internal combustion engines and multi cylinder engines	3
1.4	Coefficient of fluctuation of speed-coefficient of fluctuation of energy-design of flywheels	2
2		
2.1	Introduction- free vibration of single degree undamped systems-natural frequency-energy method- Newton's second law (free body diagram)-damped systems- logarithmic decrement.	3
2.2	Forced vibration-single degree of freedom systems-harmonic excitation-vibration isolation-transmissibility-whirling of shafts.	3
3		
3.1	Introduction to two degree of freedom systems- natural frequencies and mode shapes.	3
3.2	Introduction to design-definition, steps in design process. materials and their properties- elastic and plastic behaviour of metals, ductile and brittle behaviour	3
3.3	Shear, bending and torsional stresses, combined stresses, stress concentration factor.	4
4		
4.1	Shock and Impact loads, fatigue loading- Gerber, Goodman and Soderberg criteria, endurance limit stress, factors affecting endurance limit, factor of safety.	2
4.2	Design of riveted joints- material for rivets, modes of failure, efficiency of joint, design of boiler and tank joints, structural joints.	3
5		
5.1	Design of welded joints-welding symbols, stresses in fillet and butt welds, butt joint in tension, fillet weld in tension,	3
5.2	Fillet joint under torsion, fillet weld under bending, eccentrically loaded welds.	2
5.3	Springs- classification, spring materials, stresses and deflection of	3

	helical springs, axial loading, curvature effect, resilience, static and fatigue loading	MECHANICAL ENGINEERING
5.4	Surge in spring, critical frequency, concentric springs, end construction.	3

APJ ABDUL KALAM
TECHNOLOGICAL
UNIVERSITY

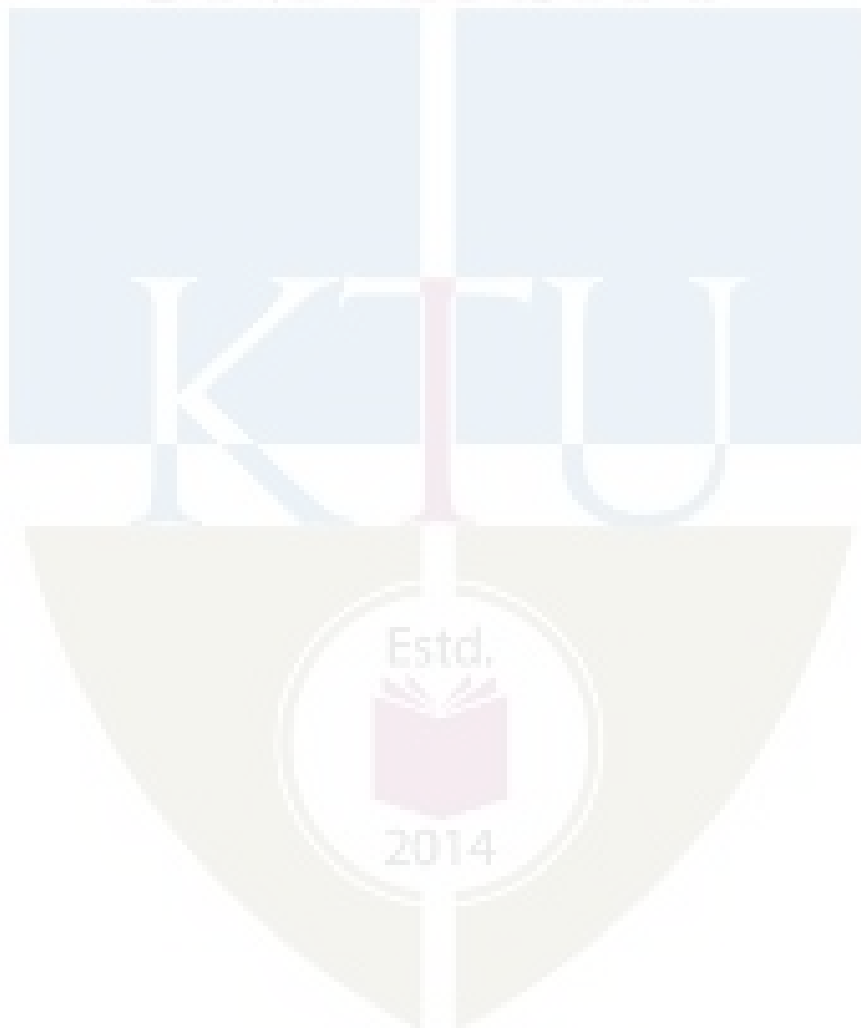

MET 306	ADVANCED MANUFACTURING ENGINEERING	CATEGORY	L	T	P	Credits
		PCC	3	1	0	4

Preamble:

1. Understand the capabilities, limitations of conventional manufacturing & machining process and what the need of advanced manufacturing processes is.
2. Understand, how to formulate tool path and program CNC machines.
3. Understand, how PLC operate and control automated equipment and systems.
4. Understand the need of atomic level surface roughness and machining process.
5. Understand the need of high velocity forming of metals.

Prerequisite: MET 205 Metallurgy and material science and MET204 Manufacturing Processes

Course Outcomes - At the end of the course students will be able to

CO 1	To be conversant with the advanced machining process and to appreciate the effect of process parameters on the surface integrity aspects during the advanced machining process.
CO 2	CNC programming, select appropriate tooling and fixtures.
CO 3	To categorize the various nontraditional material removal process based on energy sources and mechanism employed.
CO 4	Analyze the processes and evaluate the role of each process parameter during micro machining of various advanced material removal processes.
CO 5	Explain the processes used in additive manufacturing for a range of materials and applications.

Mapping of course outcomes with program outcomes (Minimum requirements)

	PO 1	PO 2	PO 3	PO 4	PO 5	PO 6	PO 7	PO 8	PO 9	PO 10	PO 11	PO 12
CO 1	3	-	-	-	2	-	-	-	-	-	-	2
CO 2	2	-	2	-	3	-	-	-	-	-	-	-
CO 3	2	-	-	-	2	-	-	-	-	-	-	2
CO 4	2	3	-	-	2	-	-	-	-	-	-	-
CO 5	2	-	-	3	2	-	-	-	-	-	2	-

Assessment Pattern

Bloom's taxonomy	Continuous Assessment Tests		End Semester Examination (Marks)
	Test I (Marks)	Test II (Marks)	
Remember	25	25	25
Understand	15	15	15
Apply	30	25	30
Analyze	10	10	10
Evaluate	10	15	10
Create	10	10	10

Mark distribution			
Total Marks	CIE marks	ESE marks	ESE duration
150	50	100	3 Hours
Continuous Internal Evaluation (CIE) Pattern:			
Attendance			10 marks
Regular class work/tutorials/assignments/self-learning (Minimum 3numbers)			15 marks
Continuous Assessment Test(Minimum 2numbers)			25 marks
<p>End semester pattern: -There will be two parts; Part A and Part B. Part A contain 10 questions with 2 questions from each module, having 3 marks for each question. Students should answer all questions. Part B contains 2 questions from each module of which student should answer anyone. Each question can have maximum 2 sub-divisions and carry 14 marks.</p>			

COURSE LEVEL ASSESSMENT QUESTIONS

Course Outcome 1 (CO1): - To be conversant with the advanced machining process and to appreciate the effect of process parameters on the surface integrity aspects during the advanced machining process.

1. How carbonyls are useful in powder metallurgy?
2. A simple integrator in which p is a constant is performed with a DDA integrator. Calculate the output Δz at the first 8 iterations. The DDA contains 3-bit register which are initially set $p=5$ and $q=0$. If each iteration is executed in 1 ms, draw the accumulated output Δz versus time.

3. What are the process parameters affecting the performance of USM
4. Draw and explain the effect of high speed on stress strain relationship of mild steel and copper

Course Outcome 2 (CO2): CNC programming, select appropriate tooling and fixtures.

1. Draw relay ladder diagram for the following sequential operations. Start button pressed, table motor started, package moves to the position of the limit switch and stops. Auxiliary features required are emergency stop, red light to indicate stop condition and green light to indicate package moving condition. Draw input and output connection diagrams also.
2. Draw a PLC ladder logic diagram to get the reciprocating motion of a punching machine using following sequential operations. One of the two motors operates when power is supplied. Motor drives the punch to one side. When it completes the required movement in one direction, a limit switch detects the position of the punch. First motor is get deactivated. Second motor starts and moves the punch to the opposite direction. When it completes required movement in opposite direction, a second limit switch detects the position of the punch. Second motor is get deactivated and first motor is started again and the process continues so as to get a continuous reciprocating motion. Also draw the input and output diagrams.
3. A DDA contains 8 bit registers. The value of its p register is constant and $P=150$ and the clock frequency is 10240pps. Calculate the output frequency of DDA
4. Describe with sketch the working and construction of recirculating ball screw used in CNC machine tools.
5. Explain linear and circular interpolations used in turning. Draw a neat sketch of circular interpolation

Course Outcome 3 (CO3): To categorize the various nontraditional material removal process based on energy sources and mechanism employed.

1. How the amplitude and frequency of vibration effects on material removal rate in Ultra Sonic Machining
2. What are the functions of electrolyte in ECM? What are the properties to be considered while selecting electrolytes in ECM?
3. What are the process parameters affecting the performance of USM

4. Which are the factors affecting its MRR in IBM process.
5. Describe the mechanism of material removal in Ion beam machining

Course Outcome 4 (CO4): Analyze the processes and evaluate the role of each process parameter during micro machining of various advanced material removal processes.

1. What is magneto rheological lapping? What are its advantages over conventional lapping?
2. Ablation of metals with Ultra short laser pulses.
3. Explain different types of elastic body waves
4. Draw and explain the effect of high speed on stress strain relationship of mild steel and copper
5. Explain with a neat schematic the fundamental principle of material removal in an abrasive jet machining process. Plot the trend for the Material Removal Rate with Nozzle Tip Distance (NTD) and explain why it rises, plateaus and falls with increasing NTD.
6. What is meant by ductile regime machine?

Course Outcome 5 (CO5): Explain the processes used in additive manufacturing for a range of materials and applications.

1. What are the two materials that are most commonly used for doing rapid prototyping of parts
2. What are the major process parameters involved in LIGA process?
3. A new car is designed, incorporating new technology, suggest how rapid prototyping could be applied for the development of the product. what are the steps followed? Discuss the factors considered.



MODEL QUESTION PAPER
SIXTH SEMESTER MECHANICAL ENGINEERING
MET 306 - ADVANCED MANUFACTURING ENGINEERING

Maximum Marks: 100

Duration: 3 Hours

Part – A

Answer all questions, each question carries 3 marks

1. Explain the different stages of sintering process in Powder metallurgy
2. Differentiate the impregnation and infiltration process in Powder metallurgy
3. What are the different word address formats used in part programming?
4. Mention the purpose of miscellaneous functions in part programming. Write any 2 M –codes with their applications
5. Describe the mechanism of material removal in Ion beam machining
6. What are the functions and desirable properties of dielectric fluid in EDM?
7. Explain the two Techniques in Explosive forming process
8. Differentiate P wave and S wave in High Velocity Forming
9. Write a note on Elastic Emission Machining
10. Explain the LIGA and its application, what is the aspect ratio in LIGA.

PART -B

Answer one full question from each module.

MODULE – 1

11. a) Explain the need and comparison between traditional and non-traditional manufacturing processes. (7 marks).
12. Explain Merchant's theory with neat sketches. (14 marks).

MODULE – 2

Write a Manual Part Program for the given figure (14 marks).

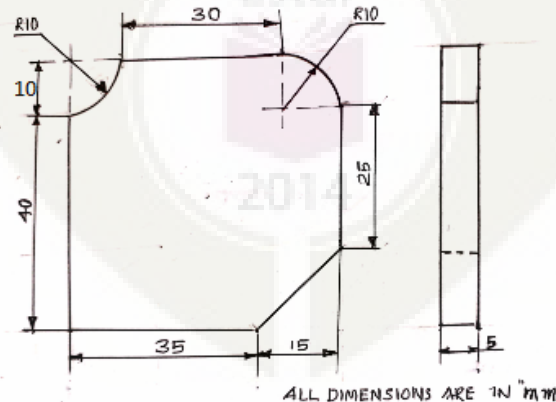

13. What is meant by interpolation in NC systems? Explain different types of interpolations. (14marks)

MODULE – 3

14. a) What are the parameters influencing the MRR in USM process (7 marks).
b) How LBM differs from and EBM (7 marks).
15. Explain IBM with neat sketch; applications and vividly the process parameters influencing on it (14marks).
16. **MODULE – 4**
a) Compare high velocity forming with conventional forming process (7 marks).
b) What are stress waves? Write the equation for finding the velocity of shear wave (7 marks).
17. Explain Electro Magnetic Forming and show that it can be applied to internal, external and surface forming operations. (14 marks).
- MODULE – 5**
18. a.Explain the material removal mechanism in Diamond turn machining process (7 marks).
b. With a neat sketch explain Diamond turn machining process. (7 marks).
19. a. With a neat sketch explain Selective Laser Sintering.(7 marks).
20. b.Describe the Laminated Object Manufacturing Process (7 marks).

SYLLABUS

Module I

Powder Metallurgy- Powder Production- Powder characteristics- Mixing – Compaction: - techniques- sintering- Theory metal cutting - Orthogonal and oblique cutting- chip formation- Merchant's theory-Friction force - cutting tool materials -Thermal aspects of machining -Tool wear and wear mechanisms - Economics of machining- Machinability- Cutting fluids.

Module II

Programmable Logic Controllers (PLC) – CNC: systems - contouring systems: principle of operation -DDA integrator: -Principle of operation, exponential deceleration –liner, circular and complete interpolator - NC part programming - Computer aided part programming - machining centers, feedback devices.

Module III

Non Traditional machining processes: - EDM, USM, ECM, LBM, EBM, PAM, IBM, AJM, AWJM.

Module IV

High velocity forming of metals - Sheet metal forming - explosive forming - Electro hydraulic forming - Electro Magnetic Forming.

Module V

Micromachining: Diamond turn mechanism, Advanced finishing processes: - Abrasive Flow Machining, Magnetic Abrasive Finishing. - Magnetorheological Finishing, Magnetorheological Abrasive Flow Finishing, Magnetic Float Polishing, Elastic Emission Machining. - Material addition processes: - stereo-lithography, selective laser sintering, fused deposition modeling, laminated object manufacturing, laser engineered net-shaping, laser welding, LIGA process.

Text Books

1. YoramKoren, Computer control of manufacturing systems, TMH
2. Jain V.K., Introduction to Micromachining, Narosa publishers.
3. Davies K and Austin E.R, Developments in high speed metal forming, the machinery publishing Co, 1970, SBN -853332053

Reference

1. ASTME, High velocity forming of metals, PHI, 1968.
2. Ibrahim Zeid, R Sivasubrahmanian CAD/CAM: Theory & Practice Tata McGraw Hill Education Private Limited, Delhi.
3. .P.Groover, E.M. Zimmers, Jr.”CAD/CAM”; Computer Aided Design and Manufacturing, Prentice Hall of India, 1987
4. PetruzellaFrank.D. - Programmable logic controllers
5. Jain V.K., Advanced Machining Processes
6. Armarego and Brown, The Machining of Metals, Prentice – Hall.
7. Paul. H. Black, Theory of Metal Cutting, McGraw Hill.
8. ASM hand book Volume 16, Machining, ASM international, 1989
9. Lal G.K., Introduction to Machining Science, New Age Publishers.

COURSE CONTENT AND LECTURE SCHEDULES.

Module	TOPIC	No.of hours	Course outcomes
1.1	Introduction: Need and comparison between traditional, non-traditional and micro & nano machining process.	2	CO1
	Powder Metallurgy: Need of P/M - Powder Production methods:- Atomization, electrolysis, Reduction of oxides, Carbonyls (Process parameters, characteristics of powder produced in each method).		
1.2	Powder characteristics: properties of fine powder, size, size distribution, shape, compressibility, purity etc.	2	CO1
	Mixing – Compaction:- techniques, pressure distribution, HIP & CIP(fundamentals to be explained in the class, self-learning topic , discretion of faculty)..		
1.3	Mechanism of sintering, driving force for pore shirking, solid and liquid phase sintering - Impregnation and Infiltration Advantages, disadvantages and specific applications of P/M.	1	
1.4	Theory metal cutting in turning: Tool nomenclature, attributes, surface roughness obtainable - Orthogonal and oblique cutting - Mechanism of metal removal - Mechanism of chip formation –chip breakers – Merchant’s theory.	3	CO1
1.5	Friction force laws in metal cutting - development of cutting tool materials (fundamentals to be explained in the class, self-learning topic, discretion of faculty).	1	CO1
1.6	Thermal aspects of machining -Tool wear and wear mechanisms - Economics of machining, Machinability, Cutting fluids(fundamentals to be explained in the class, self-learning topic, discretion of faculty).	1	CO1
2.1	Programmable Logic Controllers (PLC):need – relays - logic ladder program –timers, simple problems only.	1	CO1 CO2
2.2	Point to point, straight cut and contouring positioning - incremental and absolute systems – open loop and closed loop systems - control loops in contouring systems: principle of operation -DDA integrator:-Principle of operation, exponential deceleration –liner, circular and complete interpolator.	3	
2.3	NC part programming: part programming fundamentals - manual programming –NC coordinate systems and axes – tape format – sequence number, preparatory functions, dimension words, speed word, feed word, tool word, miscellaneous functions –	2	CO1 CO2
2.4	Computer aided part programming:- CNC languages – APT language structure.	3	CO1

	Programming exercises: simple problems on turning and drilling etc - (At least one programming exercise must be included in the end semester University examination). - machining centers, feedback devices (fundamentals to be explained in the class, self-learning topic, discretion of faculty).		CO2
3.1	Non Traditional machining processes:- Electric Discharge Machining (EDM):- Mechanism of metal removal, dielectric fluid, spark generation, recast layer and attributes of process characteristics on MRR, accuracy, HAZ etc, Wire EDM, applications and accessories.	2	CO1 CO3
	Ultrasonic Machining (USM):-mechanics of cutting, effects of parameters on amplitude, frequency of vibration, grain diameter, slurry, tool material attributes and hardness of work material, applications.	2	CO1 CO3
3.2	Electro chemical machining (ECM):- Mechanism of metal removal attributes of process characteristics on MRR, accuracy, surface roughness etc, application and limitations.	1	CO1 CO3
3.3	Laser Beam Machining (LBM), Electron Beam Machining (EBM), Plasma arc Machining (PAM), Ion beam Machining(IBM) - Mechanism of metal removal, attributes of process characteristics on MRR, accuracy etc and structure of HAZ compared with conventional process; application, comparative study of advantages and limitations of each process.	3	CO1 CO3
3.4	Abrasive Jet Machining (AJM), Abrasive Water Jet Machining (AWJM) - Working principle, Mechanism of metal removal, Influence of process parameters, Applications, Advantages & disadvantages.	1	CO1 CO3
4.1	High velocity forming of metals:-effects of high speeds on the stress strain relationship steel, aluminum, Copper – comparison of conventional and high velocity forming methods- deformation velocity, material behavior, stain distribution.	2	CO1 CO3
4.2	Stress waves and deformation in solids – types of elastic body waves- relation at free boundaries- relative particle velocity.	2	CO1 CO3
4.3	Sheet metal forming: - explosive forming:-process variable,properties of explosively formed parts, etc.	2	CO1 CO3
4.4	Electro hydraulic forming: - theory, process variables, etc, comparison with explosive forming -Electro Magnetic Forming.	2	CO1 CO3
5.1	Micromachining: Diamond turn mechanism, material removal mechanism, applications.- Advanced finishing processes: - Abrasive Flow Machining, Magnetic Abrasive Finishing.	3	CO1 CO4
5.2	Magnetorheological Finishing, Magnetorheological Abrasive Flow Finishing, Magnetic Float Polishing, Elastic Emission Machining.	3	CO4
5.3	Material addition process:- stereo-lithography, selective laser sintering, fused deposition modeling, laminated object manufacturing, laser engineered net-shaping, laser welding, LIGA process.	3	CO5

MET308	COMPREHENSIVE COURSE WORK	CATEGORY	L	T	P	CREDIT
		PCC	1	0	0	1

Preamble: The course is designed to ensure that the students have firmly grasped the foundational knowledge in Mechanical Engineering familiar enough with the technological concepts. It provides an opportunity for the students to demonstrate their knowledge in various Mechanical Engineering subjects.

Pre-requisite: Nil

Course outcomes: After the course, the student will able to:

CO1	Learn to prepare for a competitive examination
CO2	Comprehend the questions in Mechanical Engineering field and answer them with confidence
CO3	Communicate effectively with faculty in scholarly environments
CO4	Analyze the comprehensive knowledge gained in basic courses in the field of Mechanical Engineering

Mapping of course outcomes with program outcomes:

	PO 1	PO 2	PO 3	PO 4	PO 5	PO 6	PO 7	PO 8	PO 9	PO 10	PO 11	PO 12
CO 1	3	2										2
CO 2	3	2										2
CO 3	3	2										2
CO 4	2	3										2

Assessment pattern

Bloom's Category	End Semester Examination (Marks)
Remember	25
Understand	15
Apply	5

Analyze	5
Evaluate	
Create	

End Semester Examination Pattern:

A written examination will be conducted by the University at the end of the sixth semester. The written examination will be of objective type similar to the GATE examination. Syllabus for the comprehensive examination is based on following five Mechanical Engineering core courses.

MET203- MECHANICS OF FLUIDS

MET205- METALLURGY AND MATERIAL SCIENCE

MET202- ENGINEERING THERMODYNAMICS

MET204– MANUFACTURING PROCESS

MET301- MECHANICS OF MACHINERY

The written test will be of 50 marks with 50 multiple choice questions (10 questions from each module) with 4 choices of 1 mark each covering all the five core courses. There will be no negative marking. The pass minimum for this course is 25. The course should be mapped with a faculty and classes shall be arranged for practicing questions based on the core courses listed above.

Written examination: 50marks

Total : 50 marks

Course Level Assessment and Sample Questions:

- The shear stress developed in lubricating oil, of viscosity 9.81 poise, filled between two parallel plates 1cm apart and moving with relative velocity of 2 m/s is
 - 20 N/m²
 - 19.62 N/m²
 - 29.62 N/m²
 - 40 N/m²
- For a Newtonian fluid
 - Shear stress is proportional to shear strain
 - Rate of shear stress is proportional to shear strain
 - Shear stress is proportional to rate of shear strain

- (d) Rate of shear stress is proportional to rate of shear strain
3. Atomic packing factor (APF) in the case of copper crystal is
- 0.52
 - 0.68
 - 0.74
 - 1.633
4. What is the approximate strain energy expression for a dislocation of unit length, irrespective of its edge or screw character?
- $G^2b/2$
 - $Gb^2/2$
 - $G^2b/4$
 - $Gb^2/4$
5. Consider the following statements
1. Zeroth law of thermodynamics is related to temperature
 2. Entropy is related to first law of thermodynamics
 3. Internal energy of an ideal gas is a function of temperature and pressure
 4. Van der Waals' equation is related to an ideal gas
- Which of the above statements is/are correct?
- 1 only
 - 2, 3 and 4
 - 1 and 3
 - 2 and 4
6. A gas is compressed in a cylinder by a movable piston to a volume one-half of its original volume. During the process, 300 kJ heat left the gas and the internal energy remained same. What is the work done on the gas?
- 100 kNm
 - 150 kNm
 - 200 kNm
 - 300 kNm
7. Which one of the following casting processes is best suited to make bigger size hollow symmetrical pipes?
- Die casting
 - Investment casting
 - Shell moulding
 - Centrifugal casting
8. In gas welding of mild steel using an oxy-acetylene flame, the total amount of acetylene consumed was 10 litre. The oxygen consumption from the cylinder is
- 5 litre
 - 10 litre
 - 15litre
 - 20 litre
9. The number of inversions for a slider crank mechanism is
- (a) 6 (b) 5 (c) 4 (d) 3

10. Total number of instantaneous centers for a mechanism with n links are

- (a) $n/2$ (b) n (c) $(n-1)/2$ (d) $(n(n-1))/2$

Syllabus

MODULE 1

Fluids and continuum, Physical properties of fluids, Newton's law of viscosity. Ideal and real fluids, Newtonian and non-Newtonian fluids. Fluid Statics- Pressure-density-height relationship, manometers, pressure on plane and curved surfaces, center of pressure, buoyancy, stability of immersed and floating bodies

Kinematics of fluid flow: Eulerian and Lagrangian approaches, classification of fluid flow, stream lines, path lines, streak lines, stream tubes, , stream function and potential function

Equations of fluid dynamics: Differential equations of mass, energy and momentum (Euler's equation), Bernoulli's equation, Pipe Flow: Viscous flow: shear stress and velocity distribution in a pipe Hagen Poiseuille equation. Darcy-Weisbach equation,

MODULE 2

Development of atomic structure - Primary bonds: - characteristics of covalent, ionic and metallic bond - properties based on atomic bonding Crystallography: - SC, BCC, FCC, HCP structures, APF , Miller Indices: - crystal plane and direction - Modes of plastic deformation: - Slip and twinning

Classification of crystal imperfections - forest of dislocation, role of surface defects on crack initiation- Burgers vector –Frank Read source - Correlation of dislocation density with strength and nano concept - high and low angle grain boundaries– driving force for grain growth and applications

Phase diagrams: - need of alloying - classification of alloys - Hume Rothery's rule – equilibrium diagram of common types of binary systems: five types - Coring - lever rule and Gibb's phase rule - Reactions- Detailed discussion on Iron-Carbon equilibrium diagram with micro structure and properties -Heat treatment: - TTT, CCT diagram, applications - Tempering- Hardenability, Jominy end quench test, applications- Surface hardening methods.

MODULE 3

Basic Thermodynamic Concepts Macroscopic and Microscopic viewpoints, Concept of Continuum, Thermodynamic System and Control Volume, Surrounding, Boundaries, Types of Systems, Universe, Thermodynamic properties, Process, Cycle, Thermodynamic Equilibrium, Quasi – static Process, State, Point and Path function. Zeroth Law of Thermodynamics, Measurement of Temperature, reference Points, Temperature Scales.

First law of Thermodynamics - First law applied to Non flow and flow Process- SFEE

Second Law of Thermodynamics, Kelvin-Planck and Clausius Statements, Equivalence of two statements Entropy- Entropy changes in various thermodynamic processes, principle of increase of entropy and its applications, Available Energy, Availability and Irreversibility- Second law efficiency.

MODULE 4

Casting:-Characteristics of sand - patterns- cores- -chapelets- simple problems- solidification of metals and Chvorinov's rule - Elements of gating system- risering -chills

Welding:-welding metallurgy-heat affected zone- grain size and hardness- stress relieving- joint quality -heat treatment of welded joints - weldability - destructive and non destructive tests of welded joints Thermit welding, friction welding - Resistance welding, Arc Welding, Oxyacetyline welding

Rolling:- principles - types of rolls and rolling mills - mechanics of flat rolling-Defects-vibration and chatter - flat rolling -miscellaneous rolling process

Forging: methods analysis, applications, die forging, defects in forging

MODULE 5

Introduction to kinematics and mechanisms - various mechanisms, kinematic diagrams, degree of freedom- Grashof's criterion, inversions, coupler curves mechanical advantage, transmission angle. straight line mechanisms exact, approximate. Displacement, velocity analysis– relative motion - relative velocity. Instantaneous centre -Kennedy's theorem.

Acceleration analysis- Relative acceleration - Coriolis acceleration - graphical and analytical methods.

Cams - classification of cam and followers - displacement diagrams, velocity and acceleration analysis of SHM, uniform velocity, uniform acceleration, cycloidal motion

Graphical cam profile synthesis, pressure angle.

MEL332	COMPUTER AIDED DESIGN & ANALYSIS LAB	CATEGORY	L	T	P	CREDITS
		PCC	0	0	3	2
Preamble:						
<ul style="list-style-type: none"> To introduce students to the basics and standards of engineering design and analysis related to machine components. To make students familiarize with different solid modelling and analysis soft wares To convey the principles and requirements of modelling and analysis of machine elements. To introduce the preparation of part modelling and assembly modelling of machineries To introduce standard CAD packages to perform Finite Element Analysis of machine parts 						
Prerequisite:						
EST 110 - Engineering Graphics						
MEL 201 - Computer Aided Machine Drawing						
Course Outcomes - At the end of the course students will be able to						
CO1	Gain working knowledge in Computer Aided Design and modelling procedures.					
CO2	Gain knowledge in creating solid machinery parts.					
CO3	Gain knowledge in assembling machine elements.					
CO4	Gain working knowledge in Finite Element Analysis.					
CO5	Solve simple structural, heat and fluid flow problems using standard software					

Mapping of course outcomes with program outcomes (Minimum requirements)

	PO1	PO2	PO3	PO4	PO5	PO6	PO7	PO8	PO9	PO10	PO11	PO12
CO1	3	-	-	-	-	-	-	-	-	2	-	-
CO2	3	-	1	-	-	-	-	-	-	3	-	-
CO3	3	3	-	-	-	-	-	-	2	2	-	-
CO4	3	1	3	-	-	-	-	1	2	3	-	-
CO5	3	3	2	-	-	-	-	2	3	3	-	-

Mark Distribution

Total Marks	CIE Marks	ESE marks	ESE duration
150	75	75	2.5 hours

Continuous Internal Evaluation (CIE) Pattern:

Attendance	15 marks
Regular class work/Modelling and Analysis/Lab Record and Class Performance	30 marks
Continuous Assessment Test (minimum two tests)	30 marks

Continuous Assessment test pattern

Bloom's Taxonomy	Continuous Assessment Tests	
	Test 1 - PART A MODELLING (marks)	Test 2 - PART B ANALYSIS (marks)
Remember	10	10
Understand	10	10
Apply	20	20
Analyse	15	15
Evaluate	20	20
Create	25	25

End semester examination pattern

End semester examination shall be conducted on modelling and analysis and based on complete syllabus. The following general guidelines should be maintained for the award of marks

- Part A Assembly Modelling – 35 marks
- Part B Analysis – 30 marks
- Viva Voce – 10 marks.

Conduct of University Practical Examinations

The Principals of the concerned Engineering Colleges with the help of the Chairmen/Chairperson will conduct the practical examination with the approval from the University and bonafide work / laboratory record, hall ticket, identity card issued by college are mandatory for appearing practical University examinations. No practical examination should be conducted without the presence of an external examiner appointed by the University.

References Books:

1. Daryl Logan, A First course in Finite Element Method, Thomson Learning, 2007
2. David V Hutton, Fundamentals of Finite Element Analysis, Tata McGraw Hill, 2003
3. Ibrahim Zeid, CAD/ CAM Theory and Practice, McGraw Hill, 2007
4. Mikell P. Groover and Emory W. Zimmer, CAD/ CAM – Computer aided design and manufacturing, Pearson Education, 1987
5. T. R. Chandrupatla and A. D. Belagundu, Introduction to Finite Elements in Engineering, Pearson Education, 2012

Experiment List (Minimum 12 exercises)

SL.NO	PART - A (Minimum 6 models)	COURSE OUTCOMES	HOURS
1	Creation of high end part models (minimum 2 models, Questions for examinations must not be taken from this portions)	CO1, CO2	6
2	Creating assembly models of Socket and spigot joint, Knuckle Joint, Rigid flange couplings, Bushed Pin flexible coupling, Plummer block, Single plate clutch and Cone friction clutch. Pipe joints, Screw jack, Tail stock etc. (minimum 4 models)	CO1, CO2, CO3	12
	PART – B (Minimum 6 problems)		
3	Structural analysis. (minimum 3 problems)	CO4, CO5	6
4	Thermal analysis. (minimum 2 problems)	CO4, CO5	3
5	Fluid flow analysis. (minimum 1 problem)	CO4, CO5	3

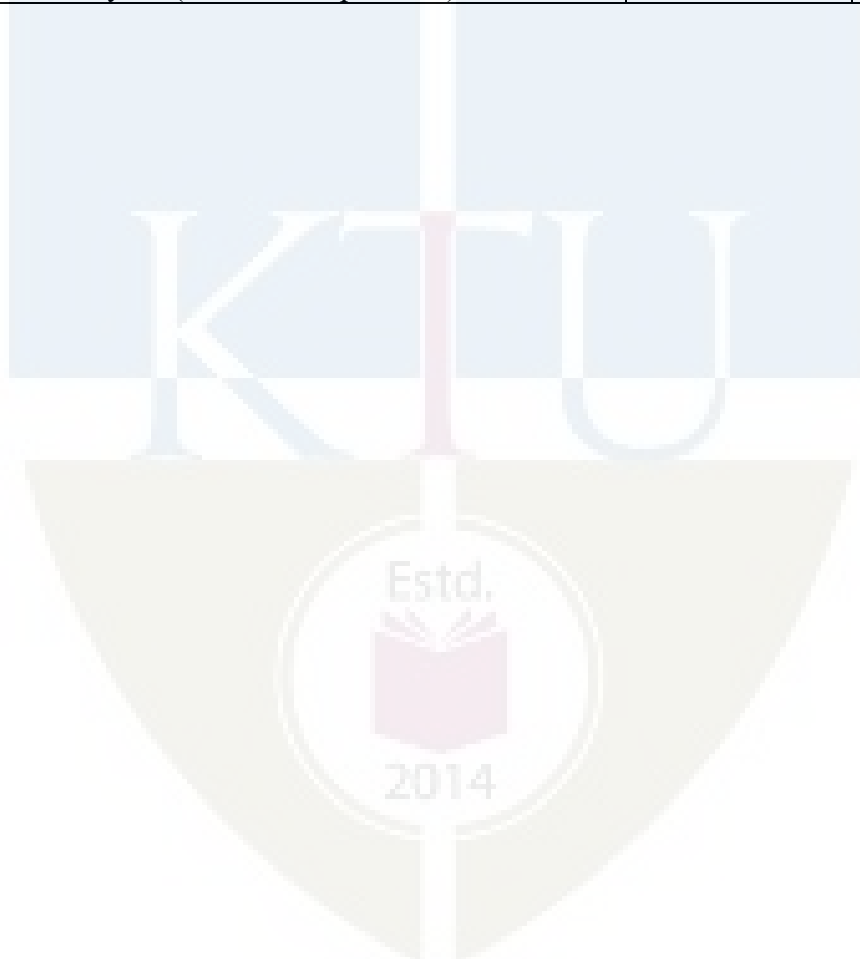

END SEMSTER EXAMINATION
MODEL QUESTION PAPER

MEL332: COMPUTER AIDED DESIGN AND ANALYSIS LAB

Duration : 2.5 hours

Marks : 75

Note :

1. All dimensions in mm
2. Assume missing dimensions appropriately
3. A4 size answer booklet shall be supplied
4. Viva Voce shall be conducted for 10 marks

PART A (ASSEMBLY MODELLING) – 35 marks

1. Create an assembly model using the part details given below

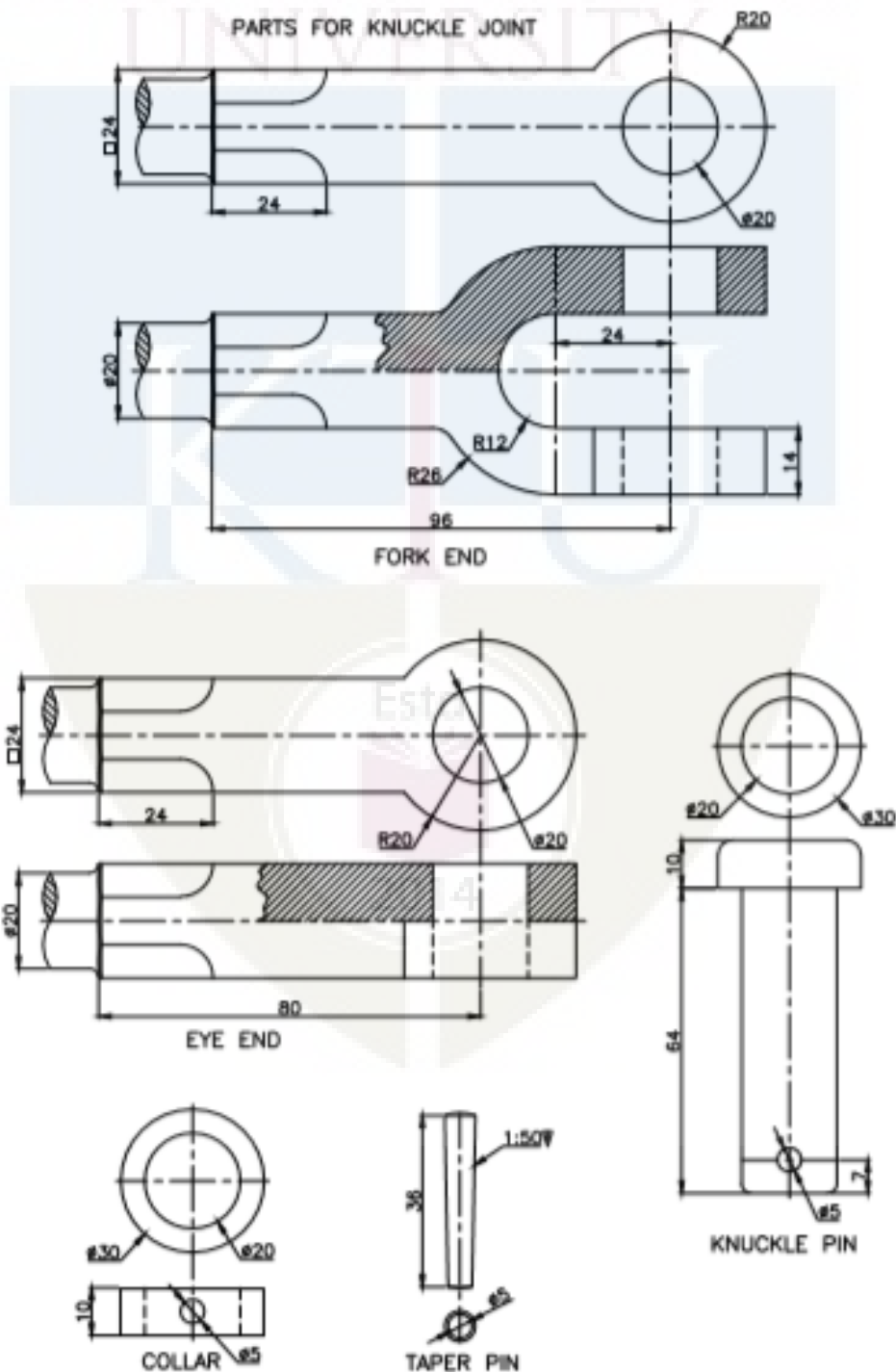

PART B (FINITE ELEMENT ANALYSIS) – 30 marks

2. Air flows over a long cylinder of 150mm diameter at a velocity of 3m/sec at a temperature of 105° F. Using this data and applying finite element technique find
 - a. Max velocity
 - b. Plot flow trajectories
 - c. Cut plot of velocity

APJ ABDUL KALAM
TECHNOLOGICAL
UNIVERSITY

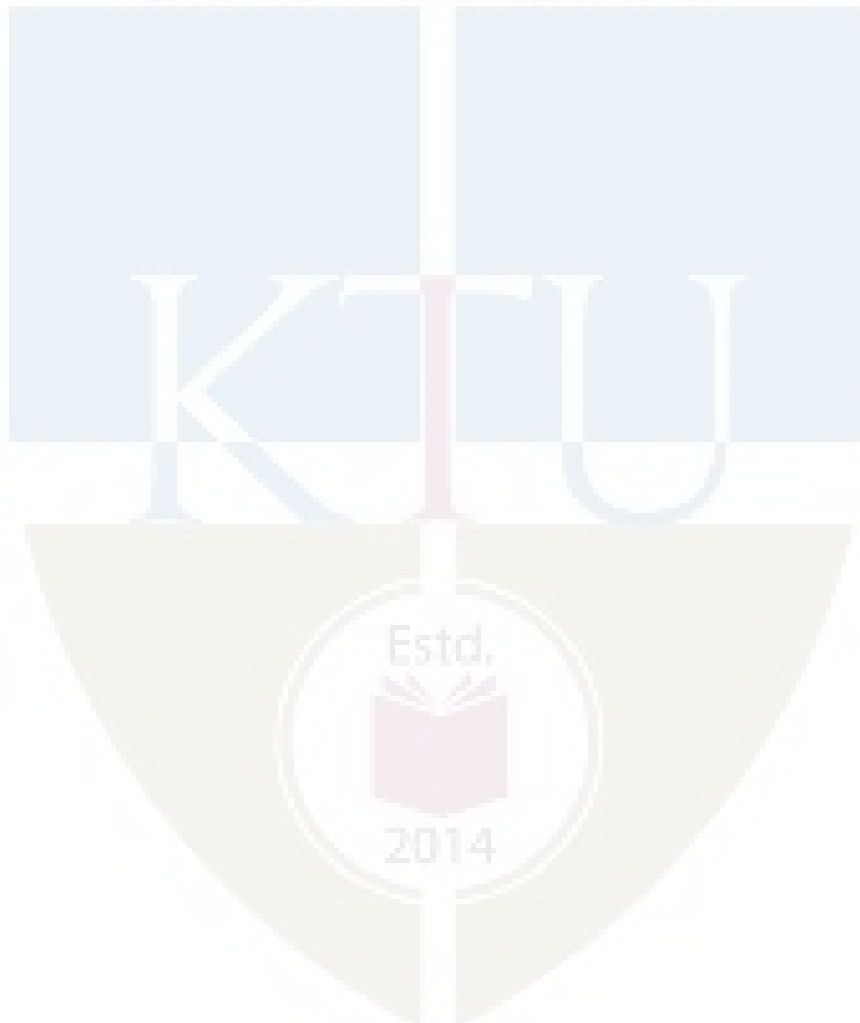

MEL334	THERMAL ENGINEERING LAB-II	CATEGORY	L	T	P	CREDIT
		PCC	0	0	3	2

Preamble: The course is intended to enable the students to get exposed to equipment related to heat and mass transfer. This includes understanding the working of equipments related to various heat transfer processes viz conduction, convection, radiation and mass transfer. These equipments are heat exchangers, refrigeration and air conditioning systems, compressor/blower and their applications in real life problems. Also the thermo physical properties of materials which are integral to these equipments will also be evaluated. Apart from this, calibration of various instruments which are essential to these equipments will be done.

Prerequisite: Should have undergone a course on Heat and Mass Transfer

Course Outcomes: After the completion of the course the student will be able to

CO 1	Evaluate thermal properties of materials in conduction, convection and radiation
CO 2	Analyse the performance of heat exchangers
CO 3	Illustrate the operational performances of refrigeration and air conditioning systems
CO 4	Perform calibration of thermocouples and pressure gauges

Mapping of course outcomes with program outcomes

	PO 1	PO 2	PO 3	PO 4	PO 5	PO 6	PO 7	PO 8	PO 9	PO 10	PO 11	PO 12
CO 1	3		2	3			2		3	2		2
CO 2	3		2	3			2		3	2		2
CO 3	3		2	3			2		3	2		2
CO 4	3		2	3			2		3	2		2

Assessment Pattern

Mark distribution

Total Marks	CIE	ESE	ESE Duration
150	75	75	2.5 hours

Continuous Internal Evaluation Pattern:

Attendance	:	15 marks
Continuous Assessment	:	30 marks
Internal Test (Immediately before the second series test)	:	30 marks

End Semester Examination Pattern: The following guidelines should be followed regarding award of marks

(a) Preliminary work	:	15 Marks
(b) Implementing the work/Conducting the experiment	:	10 Marks
(c) Performance, result and inference (usage of equipments and trouble shooting)	:	25 Marks
(d) Viva voce	:	20 marks
(e) Record	:	5 Marks

General instructions:

Practical examination is to be conducted immediately after the second series test covering entire syllabus given below. Evaluation is a serious process that is to be conducted under the equal responsibility of both the internal and external examiners. The number of candidates evaluated per day should not exceed 20. Students shall be allowed for the University examination only on submitting the duly certified record. The external examiner shall endorse the record.

Reference Books

1. Yunus A. Cengel, "Heat Transfer a Practical Approach", Tata McGraw-Hill Education, 4th Edition, 2012.
2. R. C. Sachdeva, "Fundamentals of Engineering, Heat and Mass Transfer", New Age publication, 3 rd Edition, 2012.
3. Holman J.P, "Heat transfer", Mc Graw-Hill, 10th. Ed., 2009
4. Frank P. Incropera and David P. Dewitt, Heat and Mass Transfer, John Wiley and sons, 2011
5. Kothandaraman, C.P., Fundamentals of Heat and Mass Transfer, New Age International, New Delhi, 2006

List of Exercises/Experiments: (Lab experiments may be given considering 12 sessions of 3 hours each. Minimum 12 experiments to be performed.)

1. Determination of LMTD and effectiveness of parallel flow, Counter flow and cross flow heat exchangers
2. Performance studies on a shell and tube heat exchanger
3. Development of heat transfer correlation for heat exchangers/condenser using modified Wilson Plot Method
4. Determination of heat transfer coefficients in free convection
5. Determination of heat transfer coefficients in forced convection
6. Determination of thermal conductivity of solids (composite wall/metal rod)
7. Determination of thermal conductivity of powder
8. Determination of thermal conductivity of liquids
9. Measurement of unsteady state conduction heat transfer
10. Determination of emissivity of a specimen
11. Determination of Stefan Boltzman constant
12. Measurement of solar radiation
13. Experimental study of dropwise and filmwise condensation
14. Experiments on boiling heat transfer
15. Study and performance test on refrigeration (Refrigeration Test rig)
16. Study and performance test on air conditioning equipment (Air Conditioning test rig)
17. Performance study on heat pipe
18. Calibration of Thermocouples
19. Calibration of Pressure gauge

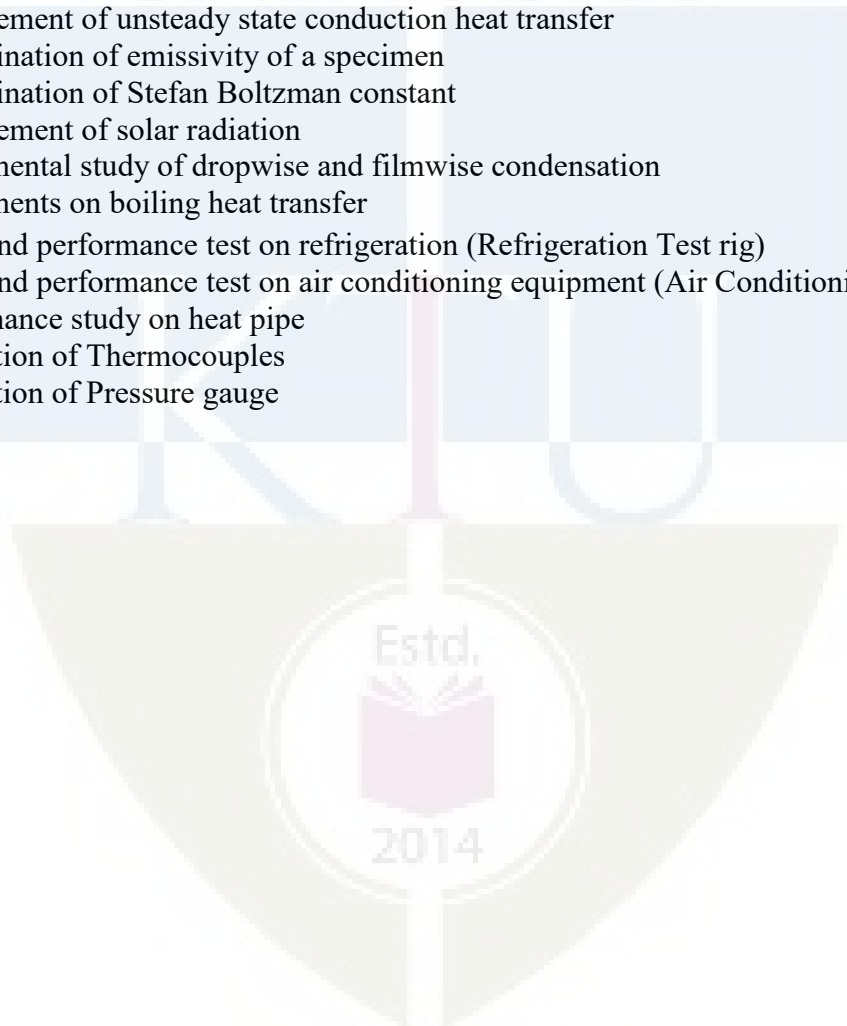

CODE MET 312	COURSE NAME NON DESTRUCTIVE TESTING	CATEGORY	L	T	P	CREDIT
		PEC	2	1	0	3

Preamble:

Nondestructive Testing (NDT) plays an extremely important role in quality control, flaw detection and structural health monitoring covering a wide range of industries. There are varieties of NDT techniques in use. This course will first cover the fundamental science behind the commonly used NDT methods to build the basic understanding on the underlying principles. It will then go on to cover the process details of each of these NDT methods.

Prerequisite: NIL

Course Outcomes: After the completion of the course the student will be able to

CO 1	Have a basic knowledge of surface NDT which enables to carry out various inspections in accordance with the established procedures.
CO 2	The students will be able to differentiate various defect types and select the appropriate NDT methods for the specimen.
CO 3	Calibrate the instrument and evaluate the component for imperfections.
CO 4	Have a basic knowledge of ultrasonic testing which enables them to perform inspection of samples.
CO 5	Have a complete theoretical and practical understanding of the radiographic testing, interpretation and evaluation.

Mapping of course outcomes with program outcomes

	PO 1	PO 2	PO 3	PO 4	PO 5	PO 6	PO 7	PO 8	PO 9	PO 10	PO 11	PO 12
CO 1	3	3	2									1
CO 2	3	3	2									1
CO 3	3	3	1									2
CO 4	3	3	2									2
CO 5	3	3	1									1

Assessment Pattern

Bloom's Category	Continuous Assessment Tests		End Semester Examination
	1	2	
Remember	25	25	25
Understand	25	25	25
Apply	30	30	30
Analyse	10	10	10
Evaluate	10	10	10
Create			

Mark distribution

Total Marks	CIE	ESE	ESE Duration
150	50	100	3 hours

Continuous Internal Evaluation Pattern:

Attendance : 10 marks

Continuous Assessment Test (2 numbers) : 25 marks

Assignment/Quiz/Course project : 15 marks

End Semester Examination Pattern: There will be two parts; Part A and Part B. Part A contain 10 questions with 2 questions from each module, having 3 marks for each question. Students should answer all questions. Part B contains 2 questions from each module of which student should answer any one. Each question can have maximum 2 sub-divisions and carry 14 marks.

Course Level Assessment Questions**Course Outcome 1 (CO1):**

1. Explain why NDT methods were initially developed
2. Describe the uses of NDT
3. Define the functionality of Destructive method

Course Outcome 2 (CO2)

1. Name the various nondestructive test methods
2. Recognize the NDT method abbreviations
3. Briefly explain each NDT method

Course Outcome 3(CO3):

1. Explain the discontinuities inherent in various manufacturing processes
2. Define the causes, prevention, and repair of those welding discontinuities
3. Explain the discontinuities inherent in various welding processes

Course Outcome 4 (CO4):

1. Explain basic principle of Radiographic examination.
2. Discuss principle of radiographic testing and give its application and limitation

3. Explain the principle, application and disadvantages of Radiographic Testing.

Course Outcome 5 (CO5):

1. Describe the various types of RT equipment
2. Describe the basic principles of gamma and X-ray generation
3. Name the three means of protection to help reduce exposure to radiation

MODEL QUESTION PAPER

SIXTH SEMESTER MECHANICAL ENGINEERING

NON DESTRUCTIVE TESTING - MET 312

Max. Marks : 100

Duration : 3 Hours

Part – A

Answer all questions, each question carries 3 marks

1. Define Non-destructive testing?
2. Explain the basic principle of Visual testing?
3. Explain the sequence of operation of Liquid penetrant testing?
4. Explain the basic principle of Liquid penetrant testing?
5. How are the materials classified based on their interaction with a magnetic field?
6. Explain the Hysteresis Loop and Magnetic Properties of a material?
7. Compare X-rays and Gamma rays?
8. What is Snell's Law and its significance in Ultrasonic Testing?
9. Define the terms (a) Radiation Energy, (b) Intensity
10. What are the physical aspects of E.C.T?

PART -B

Answer one full question from each module.

MODULE – 1

11. a) With the help of suitable examples, differentiate between destructive and nondestructive testing techniques. **(8 Mark)**

b) With the help of a neat diagram, explain computer enhanced visual inspection system. **(6 Mark)**

OR

12. a) Explain visual inspection process. Also explain about the different types of optical aids used in the process. **(8 Mark)**

b) List the applications and Limitations of Visual inspection technique in NDT **(6 Mark)**

MODULE – 2

13. a) How are the penetrants classified based on **(8 Mark)**

- a. Physical properties
- b. Removal techniques
- c. Strength of indication

b) What are the methods used to remove excess penetrants during LPI **(6 Mark)**

OR

14. a) Explain the working principle of liquid penetrant inspection (LPI). With neat sketches explain the various steps involved in performing LPI. **(8 Mark)**

b) Explain different types of developers and how it is being applied **(6 Mark)**

MODULE – 3

15. a) With the help of neat sketches explain about any four types of magnetization techniques used in magnetic particle inspection (MPI). **(8 Mark)**

b) What are the differences between dry and wet continuous MPI? **(6 Mark)**

OR

16. a) Differentiate between direct and indirect method of magnetization. Write the advantages and disadvantages of both methods. **(8 Mark)**

b) What is continuous testing and residual technique of MPI **(6 Mark)**

MODULE – 4

17. a) With the help of neat figures, differentiate between through transmission technique and pulse echo testing techniques used in ultrasonic testing. **(8 mark)**

b) What are the different types of probes used in ultrasonic testing? **(6 mark)**

OR

18. a) What are the different wave forms used in ultrasonic testing? **(8 Mark)**

b) With neat sketches explain the following: **(6 mark)**

- i) A-Scan
- ii) B-Scan
- iii) C-Scan

MODULE – 5

19. a) With neat sketches explain about the different inspection techniques in radiography testing (RT). **(8 Mark)**
 b) Explain about various steps involved in film processing in RT. **(6 mark)**

OR

20. a) Explain the following terms associated with ECT: **(8 Mark)**
 i) Lift off effect ii) Edge effect iii) End effect
 b) Explain about eddy current testing (ECT) technique in detail. **(6 mark)**

SYLLABUS

Module 1

NDT Versus Mechanical testing-Overview of the Non Destructive Testing Methods for the detection of manufacturing defects as well as material characterisation-Relative merits and limitations-various physical characteristics of materials and their applications in NDT.

Visual Inspection: Fundamentals of Visual Testing – vision, lighting, material attributes, environmental factors, visual perception, direct and indirect methods – mirrors, magnifiers, Boroscopes and fibro scopes– light sources and special lighting–calibration- computer enhanced system

Module 2

Liquid Penetrant Inspection: Principles – types and properties of liquid penetrants – developers – advantages and limitations of various methods - Preparation of test materials – Application of penetrants to parts, removal of excess penetrants, post cleaning – Control and measurement of penetrant process variables –selection of penetrant method – solvent removable, water washable, post emulsifiable – Units and lighting for penetrant testing – calibration- Interpretation and evaluation of test results - dye penetrant process applicable codes and standards.

Module 3

Magnetic Particle Inspection (MPI): Important terminologies related to magnetic properties of material, principle-magnetizing technique, procedure, and equipment, fluorescent magnetic particle testing method, sensitivity-application and limitation-Methods of magnetization, magnetization techniques such as head shot technique, cold shot technique- central conductor testing, and magnetization using products using yokes-direct and indirect method of magnetization - continuous testing of MPI, residual technique of MPI- checking devices in MPI, Interpretation of MPI, indications, advantage and limitation of MPI.

Module 4

Ultrasonic Testing: Basic principles of sound propagation, types of sound waves, Principle of UT-methods of UT, their advantages and limitations-Piezoelectric Material, Various types of transducers/probe-Calibration methods, contact testing and immersion testing, normal beam and straight beam testing, angle beam testing, dual crystal probe, ultrasonic testing techniques resonance testing, through transmission technique, pulse echo testing technique, instruments

used UT, accessories such as transducers, types, frequencies, and sizes commonly used. Reference of standard blocks-technique for normal beam inspection-flaw characterization technique, defects in welded products by UT-Thickness determination by ultrasonic method;- Study of A, B and C scan presentations-Time of Flight Diffraction (TOFD).

Module 5

Radiography: X-rays and Gamma rays, Properties of X-rays relevant to NDE - Absorption of rays - scattering. Characteristics of films- graininess, Density, Speed, Contrast. Characteristic curves. Inspection techniques like SWSI, DWSI, DWDI, panoramic exposure, real time radiography, films used in industrial radiography

Eddy Current Testing: Generation of eddy currents – effect of change of impedance on instrumentation – properties of eddy currents – eddy current sensing elements, probes, type of coil arrangement – absolute, differential, lift off, operation, applications, advantages, limitations Field factor and lift of effect, edge effect, end effect, impedance plane diagram in brief, depth of penetration of ECT, relation between frequency and depth of penetration in ECT.

Text Books

1. Baldev Raj, Practical Non – Destructive Testing, Narosa Publishing House, 1997
2. J.Prasad and C. G. K. Nair, Non-Destructive Test and Evaluation of Materials, Tata McGraw-Hill Education, 2nd edition (2011).
3. B.Raj, T. Jayakumar and M. Thavasimuthu, Practical Non Destructive Testing, Alpha Science International Limited, 3 rd edition (2007).
4. T. Rangachari, J. Prasad and B.N.S. Murthy, Treatise on Non-destructive Testing and Evaluation, Navbharath Enterprises, Vol.3, (1983).
5. Ed. Peter.J. Shull, Non-destructive Evaluation: Theory, Techniques, and Applications, Marcel Dekker (2002). 2.

Reference Books

1. C. Hellier, Handbook of Non-Destructive Evaluation, McGraw-Hill Professional, 1st edition (2001).
2. J. Thomas Schmidt, K. Skeie and P. MacIntire, ASNT Non Destructive Testing Handbook: Magnetic Particle Testing, American Society for Non-destructive Testing, American Society for Metals, 2nd edition (1989).
3. Krautkramer, Josef and Hebert Krautkramer, Ultrasonic Testing of Materials, Springer Verlag, 1990

Course Contents and Lecture Schedule

No	Topic	No. of Lectures
MODULE 1		
1.1	NDT Versus Mechanical testing-Overview of the Non Destructive Testing Methods for the detection of manufacturing defects as well as material characterisation	2
1.2	Relative merits and limitations-various physical characteristics of materials and their applications in NDT	1
1.3	Fundamentals of Visual Testing – vision, lighting, material attributes, environmental factors, visual perception, direct and indirect methods	1
1.4	Mirrors, magnifiers, Boroscopes and fibro scopes	1
1.5	light sources and special lighting, calibration- computer enhanced system	2
MODULE 2		
2.1	Liquid Penetrant Inspection: Principles – types and properties of liquid penetrants – developers	1
2.2	Advantages and limitations of various methods - Preparation of test materials	1
2.3	Application of penetrants to parts, removal of excess penetrants, post cleaning	1
2.4	Control and measurement of penetrant process variables –selection of penetrant method	1
2.5	solvent removable, water washable, post emulsifiable – Units and lighting for penetrant testing	1
2.6	calibration- Interpretation and evaluation of test results - dye penetrant process applicable codes and standards	2
MODULE 3		
3.1	Magnetic Particle Inspection (MPI): Important terminologies related to magnetic properties of material	1
3.2	Principle-magnetizing technique, procedure, and equipment, fluorescent magnetic particle testing method, Sensitivity	1
3.3	Methods of magnetization, magnetization techniques such as head shot technique, cold shot technique- central conductor testing,	1
3.4	magnetization using products using yokes-direct and indirect method of magnetization - continuous testing of MPI	1
3.5	residual technique of MPI- checking devices in MPI	1
3.6	Indications, advantage and limitation of MPI.	1
MODULE 4		
4.1	Ultrasonic Testing: Basic principles of sound propagation, types of	

	sound waves, Principle of UT-methods of UT	1
4.2	Piezoelectric Material, Various types of transducers/probe Calibration methods, contact testing and immersion testing, normal beam and straight beam testing,	1
4.3	Angle beam testing, dual crystal probe, ultrasonic testing techniques resonance testing, through transmission technique, pulse echo testing technique	1
4.4	Accessories such as transducers, types, frequencies, and sizes commonly used. Reference of standard blocks	1
4.5	Technique for normal beam inspection Thickness determination by ultrasonic method	1
4.6	Study of A, B and C scan presentations, Instruments used UT	1
4.7	Time of Flight Diffraction (TOFD).	1
MODULE 5		
5.1	Radiography: X-rays and Gamma rays, Properties of X-rays relevant to NDE - Absorption of rays - scattering	1
5.2	Characteristics of films- graininess, Density, Speed, Contrast. Characteristic curves. Inspection techniques like SWSI, DWSI, DWDI	1
5.3	Panoramic exposure, real time radiography, films used in industrial radiography	1
5.4	Eddy Current Testing: Generation of eddy currents – effect of change of impedance on instrumentation – properties of eddy currents	1
5.5	Eddy current sensing elements, probes, type of coil arrangement – absolute, differential, lift off, operation, applications, advantages, limitations	1
5.6	Field factor and lift of effect, edge effect, end effect, impedance plane diagram in brief, depth of penetration of ECT	1
5.7	Relation between frequency and depth of penetration in ECT.	1

CODE MET322	COURSE NAME COMPUTATIONAL FLUID DYNAMICS	CATEGORY	L	T	P	CREDIT
		PEC	2	1	0	3

Preamble:

This course introduces the students to finite difference methods as a means of solving different types of differential equations that arise in fluid dynamics and heat transfer. Fundamentals of numerical analysis, ordinary differential equations and partial differential equations related to fluid mechanics and heat transfer will be reviewed. Error control and stability considerations are discussed. A class of methods used in computational fluid dynamics for numerically solving the Navier-Stokes equations normally for incompressible flows will be covered in this course.

Prerequisite: MET 203 Mechanics of Fluids

Course Outcomes: After the completion of the course the student will be able to

CO 1	Understanding the governing equations dominating fluid flow and heat transfer and their mathematical and physical nature.
CO 2	Understand finite difference method to fluid flow problems and the level of errors associated with these methods.
CO 3	Understand and apply finite volume method to fluid flow and heat transfer problems.
CO 4	Understand and apply finite volume method to diffusion and convection problems and various interpolation schemes.
CO 5	Understand various methods in numerically solving Navier Stokes equation for incompressible flows.
CO 6	Understand various graphical techniques to present post processed results.

Mapping of course outcomes with program outcomes

	PO 1	PO 2	PO 3	PO 4	PO 5	PO 6	PO 7	PO 8	PO 9	PO 10	PO 11	PO 12
CO 1	3	2										
CO 2	3	2	1									
CO 3	3	3	1									
CO 4	3	3	1									
CO 5	3	2	1									
CO 6	3	2	1									

Assessment Pattern

Bloom's Category	Continuous Assessment Tests		End Semester Examination
	1	2	
Remember	10	10	10
Understand	20	20	20
Apply	20	20	70
Analyse			
Evaluate			
Create			

Mark distribution

Total Marks	CIE	ESE	ESE Duration
150	50	100	3 hours

Continuous Internal Evaluation Pattern:

Attendance	: 10 marks
Continuous Assessment Test (2 numbers)	: 25 marks
Assignment/Quiz/Course project	: 15 marks

End Semester Examination Pattern: There will be two parts; Part A and Part B. Part A contain 10 questions with 2 questions from each module, having 3 marks for each question. Students should answer all questions. Part B contains 2 questions from each module of which student should answer any one. Each question can have maximum 2 sub-divisions and carry 14 marks.

Course Level Assessment Questions

Course Outcome 1 (CO1):

- 1 Derive Navier Stokes equation in conservative form
- 2 Write a note on elliptical, parabolic and hyperbolic PDEs as applicable to CFD
- 3 Explain the applications of CFD in various industries.

Course Outcome 2 (CO2)

- 1 Explain finite difference method in brief. Give the justification for the choice for the finite difference method
- 2 Write a note on central and upwind difference schemes for one dimensional steady convection-diffusion equation
- 3 Obtain a 5-point centre-difference scheme for $\frac{\partial^2 \phi}{\partial x^2}$ at grid-point i using $\phi_{i-2}, \phi_{i-1}, \phi_i, \phi_{i+1}, \phi_{i+2}$ and find its truncation error.

Course Outcome 3(CO3):

1. Consider a heat conduction problem governed by $\frac{\partial T}{\partial t} = \alpha \frac{\partial^2 T}{\partial x^2}$. Develop a finite difference representation for this equation by the control-volume approach. Do not assume that the grid is uniform.
2. Explain the features of TDMA method
3. Write a note on explicit and implicit approaches and stability criteria.

Course Outcome 4 (CO4):

1. A property ϕ is transported by means of convection and diffusion through the one-dimensional domain. The governing equation is $[Dw \frac{\partial \phi}{\partial x} - (De - \phi Fe) \frac{\partial \phi}{\partial x} + (Fe - \phi Fw)] \frac{\partial \phi}{\partial x} = P \frac{\partial \phi}{\partial x} - Dw \frac{\partial \phi}{\partial x} + (De - \phi Fe) \frac{\partial \phi}{\partial x}$; the boundary conditions are $\phi_0 = 1$ at $x = 0$ and $\phi L = 0$ at $x = L$. Using QUICK scheme for convection and diffusion, calculate the distribution of ϕ as a function of x for (i) Case 1: $u = 0.1$ m/s, (ii) Case 2: $u = 2.5$ m/s

2. Explain Crank-Nicolson implicit scheme used for solving the parabolic partial differential equations
3. A property ϕ is transported by means of convection and diffusion through the one-dimensional domain. The governing equation is $[D_w \frac{\partial \phi}{\partial x} - \Gamma \frac{\partial^2 \phi}{\partial x^2}] = P - D_w \frac{\partial \phi}{\partial x} - \Gamma \frac{\partial^2 \phi}{\partial x^2}$; the boundary conditions are $\phi_0 = 1$ at $x = 0$ and $\phi_L = 0$ at $x = L$. Using upwind differencing scheme for convection and diffusion, calculate the distribution of ϕ as a function of x for (i) Case 1: $u = 0.1$ m/s, (ii) Case 2: $u = 2.5$ m/s with the coarse five-point grid

Course Outcome 5 (CO5):

1. Derive the expression for vorticity at the wall in terms of stream function. The expression should contain the interior points only. One could use no-slip velocity boundary condition at the wall in deriving the expression.
2. Write vorticity stream function equations
3. Describe the philosophy of Pressure Correction technique. Explain how boundary conditions are specified consistent with the philosophy of Pressure Correction method

Course Outcome 6 (CO6):

1. Explain SIMPLE Algorithm
2. Derive Pressure Correction formula considering two dimensional flows and explain step by step procedure for SIMPLE algorithm
3. Write a note on computer graphics techniques used to present post processed CFD results

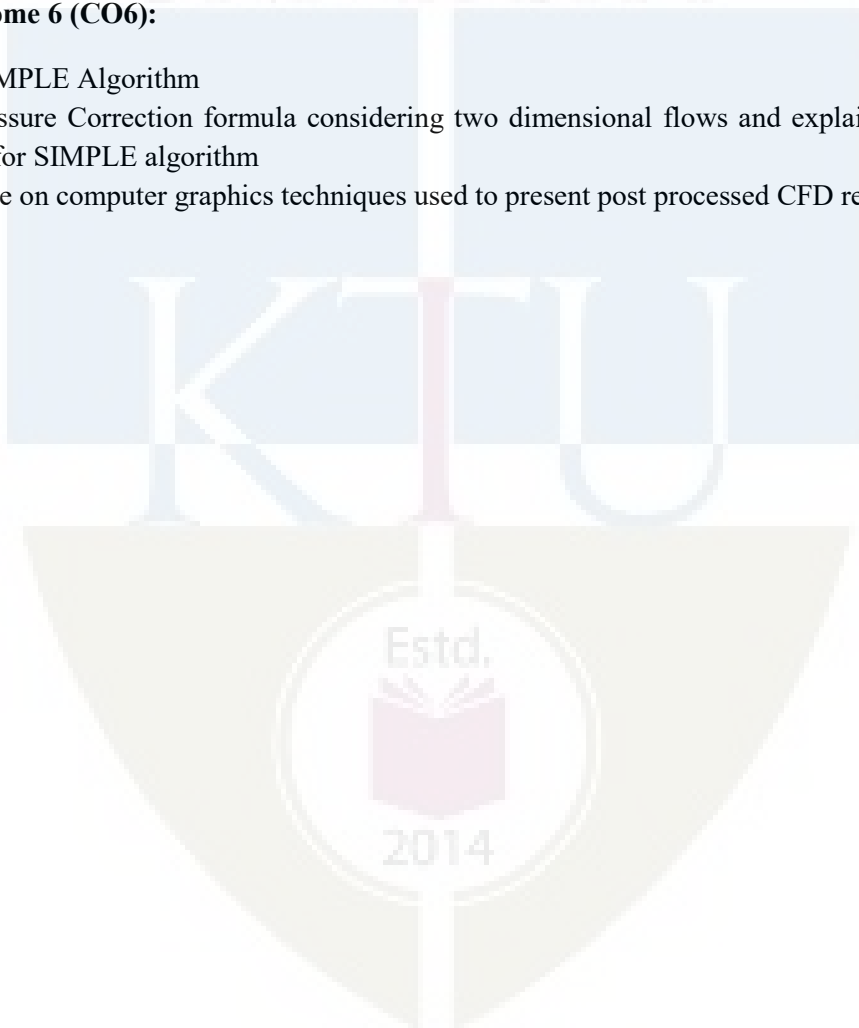

APJ ABDUL KALAM TECHNOLOGICAL UNIVERSITY
SIXTH SEMESTER B.TECH DEGREE EXAMINATION

Course Code: MET 322

Course Name: COMPUTATIONAL FLUID DYNAMICS

Max. Marks: 100

Duration: 3 Hours

PART A

ANSWER ALL QUESTIONS, EACH QUESTION CARRIES 3 MARKS)

1. Explain the merits and demerits of numerical approaches over theoretical and experimental approaches.
2. Show that the second-order wave equation is a hyperbolic partial differential equation.
3. Using Taylor series, derive a first order and a second order difference equation for $\frac{\partial u}{\partial y}$.
4. Explain the relaxation techniques used in numerical schemes.
5. Explain Dirichlet, Neumann, and Robins type boundary conditions.
6. Derive the difference equation for steady one-dimensional heat conduction problem.
7. Discuss a situation where upwind differencing scheme is preferred over central differencing scheme.
8. Suggest a numerical difference scheme for which numerical false diffusion is desirable and justify your suggestion.
9. Explain any three graphical methods to present CFD results.
10. Discuss the importance of staggered grid in numerically solving incompressible viscous flow problems. (10 X 3 = 30 Marks)

PART B

Module 1

(ANSWER ONE FULL QUESTION FROM EACH MODULE)

11. Explain the significance of parabolic, hyperbolic and elliptic partial differential equations in a numerical perspective. (14 Marks)
12. Write down the Navier-Stokes equation in vector form by clearly mentioning the solution vector, flux vector and source vector. Convert the Navier-Stokes equations into non-dimensional form. (14 Marks)

Module 2

13. Consider the viscous flow of air over a flat plate. At a given station in the flow direction, the variation of the flow velocity, u , in the direction perpendicular to the plate (the y direction) is given by the expression $u = 21582 \left(1 - e^{\left(\frac{-y}{L} \right)} \right)$ where $L =$ characteristic length = 0.05 m. The unit of u is m/s. The viscosity coefficient $\mu = 1.81 \times 10^{-5}$ kg/(m.s). Using the equation for u , find the values of u at discrete grid points equally spaced in the y direction with $\Delta y = 0.002m$. With the values obtained at discrete grid points located at $y=0, 0.002$ m, 0.004 m, and 0.006 m, calculate the shear stress at the wall τ_w (a) using a first order difference equation and (b) second order difference equation. Compare these calculated finite difference results with the exact value of τ_w which can be found by making use of the expression for u . (14 Marks)

14. The equation for deflection of a beam is given by $\frac{d^2y}{dx^2} - e^{x^2} = 0$ and deflection at $x = 0$ and $x = 1$ are given by $y(0) = 0$ and $y(1) = 0$. Use the difference equations to find the approximate deflection at $x = 0.25, 0.5$, and 0.75 . (14 Marks)

Module 3

15. Consider the problem of source-free heat conduction in an insulated rod of 0.5 m length whose ends are maintained at constant temperatures of 100°C and 500°C respectively. The one-dimensional problem is governed by $\frac{d}{dx} \left(\frac{k \cdot dT}{dx} \right) = 0$. Calculate the steady state temperature distribution in the rod using finite volume method. Thermal conductivity k equals 1000 W/m.K, cross-sectional area A is $10 \times 10^{-3} \text{m}^2$. Use cell centered grid points. (14 Marks)
16. Two plastic sheets, each 5 mm thick, are to be bonded together with a thin layer of adhesive that fuses at 140 °C. For this purpose, they are pressed between two surfaces at 250 °C. Using finite volume method, determine the time for which the two sheets should be pressed together, if the initial temperature of the sheets (and the adhesive) is 30 °C. For plastic sheets, thermal conductivity $k=0.25$ W/m-K, specific heat $C=2000$ J/kg-K and density, $\rho=1300$ kg/m³. (14 Marks)

Module 4

17. A property ϕ is transported by means of convection and diffusion through the one-dimensional domain $0 \leq X \leq L$. The governing equation is $\frac{d}{dx} \rho u \phi = \frac{d}{dx} \left(\Gamma \left(\frac{d\phi}{dx} \right) \right)$; the boundary conditions are $\phi_0 = 1$ at $x = 0$ and $\phi_L = 0$ at $x = L$. Using five equally spaced cells and the central differencing scheme for convection and diffusion, calculate the distribution of ϕ as a function of x for $u = 0.1$ m/s. Compare the results with the analytical solution $(\phi - \phi_0) \left(\phi_L - \phi_0 \right)^{\frac{\rho u x}{\Gamma}} \left(\left(\frac{\rho u x}{\Gamma} \right) - 1 \right)$. (14 Marks)
18. Make a comparison of central differencing scheme and upwind differencing scheme. Explain the influence of numerical false diffusion on these two schemes. (14 Marks)

Module 5

19. Derive the stream function- vorticity formulation for the Navier-Stokes equation by clearly stating the assumptions. (14 Marks)
20. Explain the SIMPLE algorithm. Make a discussion of the pressure correction equation and the boundary conditions for the pressure correction equation. (14 Marks)

<p>MODULE : 1 Governing equations of fluid mechanics and heat transfer; fundamental equations – continuity equation, momentum equation and energy equation; non-dimensional form of equations; boundary layer equations for steady incompressible flows. Physical and mathematical classifications of partial differential equations. Comparison of experimental, theoretical and numerical approaches; applications of CFD.</p>
<p>MODULE : 2 Discretization-converting derivatives to their finite difference forms-Taylor’s series approach, polynomial fitting approach; forward, backward and central differencing Schemes. Discretization error, truncation error, round off error. Consistency and numerical stability, iterative convergence, condition for convergence, rate of convergence; under and over relaxations, termination of iteration.</p>
<p>MODULE : 3 Finite volume method for Steady one–dimensional conduction problems; handling of boundary conditions; two-dimensional steady state conduction problems; point-by-point and line-by-line method of solution; dealing with Dirichlet, Neumann, and Robins type boundary conditions; tri-diagonal matrix algorithm; transient heat conduction problems - explicit, implicit, Crank-Nicholson and ADI schemes.</p>
<p>MODULE : 4 Finite volume method for diffusion and convection-diffusion problems; steady one-dimensional convection and diffusion; upwind, hybrid, power-law and QUICK schemes; false diffusion.</p>
<p>MODULE : 5 Computation of the flow field using stream function-vorticity formulation. Two dimensional incompressible viscous flow. Staggered grid. Pressure correction methods. Solution algorithm for pressure-velocity coupling in steady flows-SIMPLE algorithm. Boundary conditions for the pressure correction method. Computer graphics techniques to present CFD results.</p>

Text Books

1. S V Patankar, Numerical Heat Transfer and Fluid Flow, McGraw-Hill
2. John D Anderson Jr, Computational Fluid Dynamics, McGraw-Hill Book Company

Reference Books

1. K Muralidhar, T Sundararakjan, Computational Fluid Flow and Heat transfer, Narosa, 2nd Edition, 2011
2. Tapan K Senguptha, Computational Fluid Dynamics, University Press, 2005

Course Contents and Lecture Schedule

No	Topic	No. of Lectures
Module I		
1	Fundamental equations fluid mechanics and heat transfer	1
2	Continuity equation, momentum equation and energy equation;	2
3	Non-dimensional form of equations	1
4	Boundary layer equations for steady incompressible flows.	1
5	Physical and mathematical classifications of partial differential equations.	1
6	Comparison of experimental, theoretical and numerical approaches; applications of CFD.	1
Module II		
1	Discretization-converting derivatives to their finite difference forms-Taylor's series approach and polynomial fitting approach	1
2	Forward, backward and central differencing Schemes.	1
3	Discretization error, truncation error, round off error	1
4	Consistency and numerical stability	1
5	Iterative convergence, condition for convergence, rate of convergence	1
6	Under and over relaxations, termination of iteration.	1
Module III		
1	Finite volume method for steady one-dimensional conduction problems	1
2	handling of boundary conditions;	1
3	two-dimensional steady state conduction problems; point-by-point and line-by-line method of solution;	1
4	dealing with Dirichlet, Neumann, and Robins type boundary conditions;	1
5	tri-diagonal matrix algorithm;	1
6	transient heat conduction problems -explicit, implicit, Crank-Nicholson schemes	2
7	ADI scheme	1
Module IV		
1	Finite volume method for diffusion and convection-diffusion problems;	1
2	Upwind scheme for steady one-dimensional convection and diffusion	1
3	Hybrid scheme and power-law scheme	2
4	QUICK scheme	1
5	Numerical false diffusion	1
Module V		
1	Computation of the flow field using stream function-vorticity formulation.	2
2	Two dimensional incompressible viscous flow.	1
3	Staggered grid. Pressure correction methods.	1
4	Solution algorithm for pressure-velocity coupling in steady flows-SIMPLE algorithm.	2
5	Boundary conditions for the pressure correction method.	1
6	Computer graphics techniques to present CFD results.	1

CODE MET332	COURSE NAME ADVANCED MECHANICS OF SOLIDS	CATEGORY	L	T	P	CREDIT
		PEC	2	1	0	3

Preamble: This elective course is designed to guide the student to move to the next level of what was included in the third semester course on Strength of Materials (MET 201 MECHANICS OF SOLIDS). Some of the materials which are usually preliminary for a paper like this, have got discussed in that prerequisite, and hence not repeated here. Application of stress and strain analysis in two and three dimensions to solve engineering problems is what is aimed at. The course is supposed to serve necessary background material for future courses on Finite Element Method, and advanced courses on Elasticity.

Prerequisite: MET 201 MECHANICS OF SOLIDS

Course Outcomes: After the completion of the course the student will be able to

CO 1	Formulate the field equations of Elasticity.
CO 2	Model some engineering problems as two-dimensional, for easy solutions involving a Stress Function.
CO 3	Develop solutions for axi-symmetric problems for applications in thick pressure vessels and in rotating circular discs.
CO 4	Extend the basic ideas related to theory of elastic flexure, for skewed loading and for beams which are curved.
CO 5	Apply solution methods for torsion in components with non-circular cross sections and thin walled structures.

Mapping of course outcomes with program outcomes

	PO 1	PO 2	PO 3	PO 4	PO 5	PO 6	PO 7	PO 8	PO 9	PO 10	PO 11	PO 12
CO 1	3	2	1									
CO 2	2	3	1									
CO 3	2	3	1									
CO 4	3	2	1									
CO 5	2	3	1									

Assessment Pattern

Bloom's Category	Continuous Assessment Tests		End Semester Examination
	1	2	
Remember	10	10	10
Understand	20	20	20
Apply	20	20	70
Analyse			
Evaluate			
Create			

Mark distribution

Total Marks	CIE	ESE	ESE Duration
150	50	100	3 hours

Continuous Internal Evaluation Pattern:

Attendance : 10 marks

Continuous Assessment Test (2 numbers) : 25 marks

Assignment/Quiz/Course project : 15 marks

End Semester Examination Pattern: There will be two parts; Part A and Part B. Part A contain 10 questions with 2 questions from each module, having 3 marks for each question. Students should answer all questions. Part B contains 2 questions from each module of which student should answer any one. Each question can have maximum 2 sub-divisions and carry 14 marks.

Course Level Assessment Questions**Course Outcome 1 (CO1):**

1. Formulate all Field equations of elasticity.
2. Establishing the compatibility equations.
3. Realizing the differences between the formulation strategies of solutions in solid mechanics.
4. Formal proof for the uniqueness of the intended solutions.

Course Outcome 2 (CO2)

1. Realization that a vast majority of problems reduces to two-dimensional (either plane-stress or plane strain).
2. Formulating the Airy's stress function for two-dimensional problems.
3. Extending the Airy's method to solve practical problems like that encountered in contact analysis.

Course Outcome 3(CO3):

1. Formulation of equation for stresses and deflections in axi-symmetric problems.
2. Extend the axi-symmetric solutions for engineering applications in structures which are pressurised from the inside, as well as outside.
3. Extend the axi-symmetric theory to solve stresses and deformations in spinning discs.

Course Outcome 4 (CO4):

1. Extend the basic elastic flexure formula to cases when the load is skewed.
2. Develop the necessary framework to solve stresses in curved beams.

Course Outcome 5 (CO5):

1. Applying the St. Venant's torsion theory for non-circular cross sections
2. Applying Prandtl's Stress Function to solve Torsion and its applicability in terms of Membrane Analogy.
3. Stress analysis in thin walled closed sections.

Model Question paper**APJ ABDUL KALAM TECHNOLOGICAL UNIVERSITY**

SIXTH SEMESTER B.TECH DEGREE EXAMINATION

Course Code : MET332 Course Name : ADVANCED MECHANICS OF SOLIDS

Max. Marks : 100

Duration : 3 Hours

PART – A (ANSWER ALL QUESTIONS, EACH QUESTION CARRIES 3 MARKS)

1. Discuss the different types of boundary conditions encountered in the solution of elasticity problems.
2. What are Compatibility equations? Why are they essential in solving elasticity problems?
3. Express stress-strain relations in Matrix format for Plane-Stress and Plane-Strain problems.
4. Elucidate an example for the application of superposition in solving contact stress problems.
5. Derive expressions for circumferential and axial stresses in a thin cylindrical pipe of diameter 'd', thickness 't' and subjected to internal pressure 'P'.
6. Derive expressions for Circumferential Strain and Radial Strain for a two-dimensional thick cylinder (axi-symmetric) problem.
7. Discuss the significance of Shear-Centre in solving Bending of beams.
8. State all relevant assumptions in solving bending stress problems in curved beams using Winkler-Bach theory.
9. Elucidate the difference in approach between St. Venant's theory and Prandtl's theory in the solution of torsion problems.

10. How are torsion problems solved experimentally, making use of Prandtl's membrane analogy?

PART – B (ANSWER ONE FULL QUESTION FROM EACH MODULE)

MODULE – 1

11. (a) For a two-dimensional stress problem described using cylindrical coordinates, derive the equations of equilibrium in terms of (r, θ) . (10 Marks)

(b) For the following plane strain distribution, verify whether the compatibility condition is satisfied:

$$\epsilon_{xx} = 3x^2y, \epsilon_{yy} = 4y^2x + 10^{-2}, \gamma_{xy} = 2xy + 2x^3 \quad (4 \text{ Marks})$$

12. (a) Given the fact that the strain energy density is positive-definite, show that the field equations of elasticity yields a Unique solution for a given system of forces and boundary conditions. (8 marks)

(b) Derive the equations of equilibrium in rectangular Cartesian coordinates. (6 Marks)

MODULE – 2

13. Figure shows a cantilever (of depth $2c$) loaded by u.d.l. of magnitude 'q'. If the Airy's stress function for this problem is $\phi = A [y^5 - 2c^2y^3 - 10x^2y^3 + 30c^2x^2y - 20c^3x^2]$, (a) show that it is an acceptable stress function for Airy's method and (b) evaluate 'A' for this problem. (14 Marks)

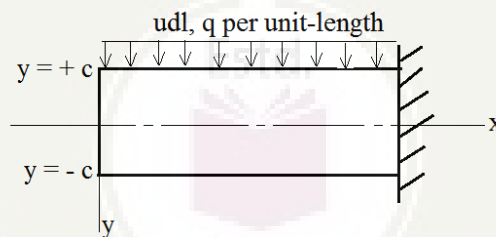

14. If the Airy' stress function (ϕ) in polar coordinates for solving contact stresses due to line-load on a straight boundary is $\phi(r, \theta) = - (W/L \pi) r \theta \sin \theta$ (where 'W/L' is the normal load per unit length), (a) show that it is an acceptable stress function for Airy's method (b) evaluate stresses for this two-dimensional stress-field (c) Show that the reactions offered by the resulting stress balances the externally applied load.

(14 Marks)

MODULE – 3

15. (a) Assuming plane stress, the stresses in a hollow thick cylinder of radius 'a' and external radius 'b' subjected to uniform (compressive) pressure of magnitude P_a and P_b inside and outside respectively is of the form

$$\sigma_r = \frac{E}{1-\nu^2} \left[C_1(1+\nu) - C_2(1-\nu) \frac{1}{r^2} \right]$$

$$\sigma_\theta = \frac{E}{1-\nu^2} \left[C_1(1+\nu) + C_2(1-\nu) \frac{1}{r^2} \right]$$

where 'r' is the radius at any point. Evaluate the constants C_1 and C_2 .

(b) Based on the above, develop expressions for (i) an internally pressurised thick cylinder and (ii) thick cylinder under external pressure. Plot the variation of stresses across thickness for both cases. (14 Marks)

16. A rotating disc ($N=3500$ rpm) with a hole has an inner radius of 10 cm and outer radius of 35 cm. If the Poisson's ratio of the material is 0.3 and density is 8050 kg/m^3 , (i) calculate and plot the distribution of radial and circumferential stresses across the radius (ii) Find the maximum values of radial and circumferential stresses. (14 Marks)

MODULE - 4

17. Find the maximum stress in the section A-B, if the cross-section is a square of sides 3 cm x 3 cm, for an applied load of $P=3000\text{N}$. Also, plot the variation of stresses across section, indicating the location of centroid and the neutral-axis. (14 Marks)

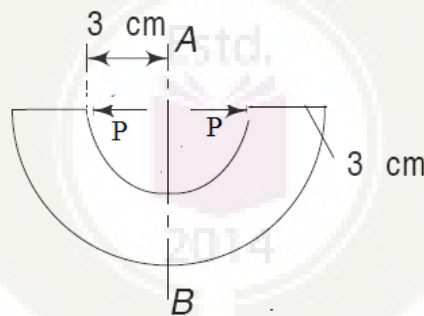

18. A rectangular beam with a 10 cm \times 15 cm section is used as a simply supported beam of 3 m span. It carries a uniformly distributed load of 1470 N per meter. The load acts in a plane making 30° with the vertical. Calculate the maximum flexural stress at all corners of the cross-section at the mid-span and also locate the neutral axis for the same section. (14 Marks)

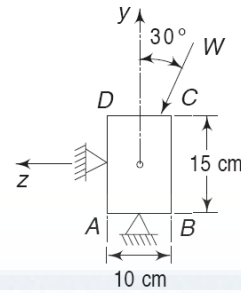
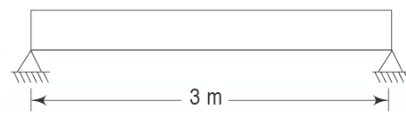

MODULE - 5

19. Show that the stress function $m \left[\frac{x^2}{a^2} + \frac{y^2}{b^2} - 1 \right]$ is a valid Prandtl's stress function for solving torsion problem on an elliptical cross section of major axis $2a$ and minor axis $2b$. Derive expressions for (i) Angle of twist per unit length (ii) Torsional rigidity (iii) Stresses (iv) Max. Stress. (14 Marks)

20. The cross-section of an aerofoil- model in a small wind-tunnel tested for the torque induced due to circulation around it, is idealized as shown in figure. If the shear strength of the material used for the model is 40 MPa and if the shear-modulus, 'G' is 26 GPa, find the limiting-torque for which it can be tested. How much would it deform (angular deflection) under this condition. Use 3mm wall thickness all around. (14 Marks)

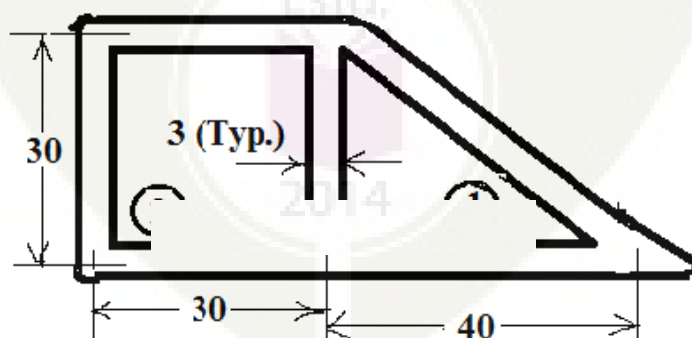

All dimensions in mm

Syllabus

Module 1

Field equations of Elasticity: Equations of equilibrium in rectangular and cylindrical polar coordinates – strain-displacement-relations - constitutive equations. Boundary value problems: Different boundary conditions- Examples for Displacement Formulation/ Force Formulation. Compatibility equations - Uniqueness of solution and superposition- St. Venant's principle.

Module 2

Two dimensional problems in elasticity: Stress-strain relations for Plane stress and Plane strain cases. Airy's Stress Functions for solution of stresses: problems in Rectangular as well as in Polar coordinates- contact stresses due to concentrated normal force (line load) on a straight boundary using Airy's stress function, and its extension to solve for stresses due to uniform normal pressure.

Module 3

Axisymmetric problems: Thin cylinders pressurized from inside, and thick cylinders pressurized from inside and outside - Rotating disks.

Module 4

Unsymmetrical bending of straight beams possessing two axes of symmetry-shear center-Winkler Bach theory for Bending of curved beams (with rectangular cross-section).

Module 5

Torsion of non-circular bars: St. Venant's and Prandtl's methods- solutions for elliptical cross-section. Membrane analogy –torsion of thin walled closed sections .

Text Books

1. Nambudiripad K. B. M, "Advanced Mechanics of Solids- A Gentle Introduction", Narosa Publishing House, First Edition, 2018.
2. Srinath L. S., "Advanced Mechanics of Solids", Tata McGraw Hill Publishing Company, Third Edition, 2009.
3. Jose S., "Advanced Mechanics of Materials", Pentagon Educational Services, Second Edition, 2017.
4. Anil Lal S., "Advanced Mechanics of Solids", Siva Publications and Distributors, First Edition, 2017.

Reference Books

1. Ragab A. R. and Bayoumi S. E., “Engineering Solid Mechanics, Fundamentals and Applications”, CRC Press, First Edition, 2018.
2. Timoshenko S. P., and Goodier J. N., “Theory of Elasticity”, McGraw Hill (India), Private Limited, NewDelhi, Third Edition, 2010.
3. Sadd M. H., “Elasticity: Theory, Applications and Numerics”, Academic Press, Indian reprint, 2nd edition, 2012.

Course Contents and Lecture Schedule

No	Topic	No. of Lectures
1	Module-1: Field Equations	7
1.1	Review of Stress-tensor, strain-displacement relations and strain tensor. Derivation of Equilibrium equations in rectangular and polar coordinates.	2 Hours
1.2	Generalised Hooke’s law for linearly elastic, homogeneous isotropic solids	1 Hour
1.3	Boundary conditions in Elasticity problems with examples, Displacement Formulation/ Force Formulation Uniqueness of Solutions, Method of Super position	2 Hours
1.4	Compatibility equations, St. Venants Principle	2 Hours
2	Module-2: Two-dimensional problems	7
2.1	Stress-strain relations for Plane –stress and plane strain conditions	1 Hour
2.2	Formulation of the Airys stress function in Rectangular and Polar Coordinates	2 Hours
2.3	Illustrative examples for solutions using Airy’s stress function	2 Hours
2.4	Contact stresses due to concentrated normal force (line load) on a straight boundary using Airy’s stress function, and its extension to solve for stresses due to uniform normal pressure.	2 Hours
3	Module-3: Axi-symmetric Problems	7
3.1	Stresses in Thin Cylindrical shells and numerical problems.	1 Hour
3.2	Axisymmetric problems: Basic Formulation	1 Hour
3.3	Application to thick shells	1 Hour
3.4	Numerical problems related to thick shells	1 Hour
3.5	Formulation of rotating disks	1 Hour
3.6	Numerical problems related to rotating disks	2 Hours
4	Module-4: Special Topics in Bending	7
4.1	Unsymmetrical bending of straight beams possessing two axes of	1 Hour

	symmetry.	
4.2	Numerical problems related to Unsymmetrical bending of straight beams	2 Hours
4.3	Shear Centre	1 Hour
4.4	Winkler Bach theory for Bending of curved beams	1 Hour
4.5	Numerical problems related to Unsymmetrical bending of straight beams	2 Hours
5	Module-5: Torsion of Non-Circular Sections	7
5.1	St. Venant's torsion theory	2 Hours
5.2	Prandtl's torsion theory	1 Hour
5.3	Membrane Analogy	1 Hour
5.4	Torsion of thin walled cross sections	1 Hour
5.5	Numerical problems on torsion of thin walled sections	2 Hours

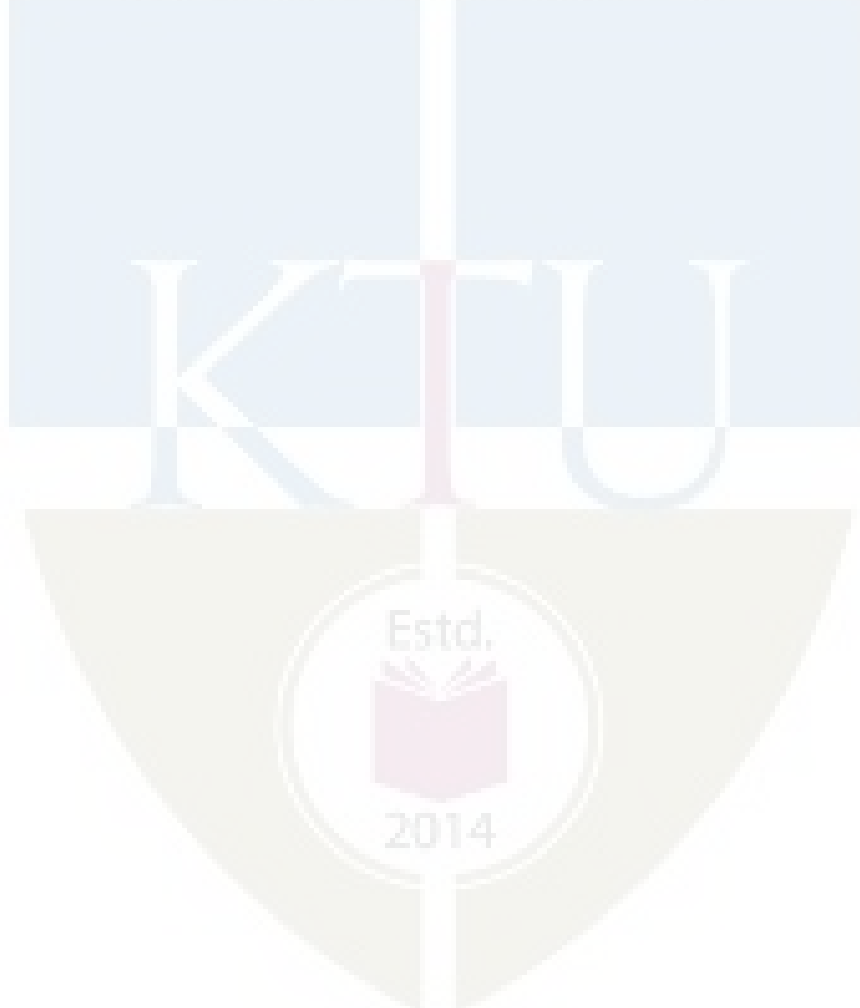

CODE	COURSENAME	CATEGORY	L-T-P	CREDITS
MET 342	IC ENGINE COMBUSTION AND POLLUTION	PEC	2-1-0	3

Preamble :

This course provides basic concepts on fuel-air mixing, theory of combustion in IC engines. To provide knowledge on emission control technologies of IC engines.

Prerequisite : Thermal Engineering

Course Outcomes :

After completion of the course the student will be able to

CO1	Explain the basic concepts of fuel air mixing
CO2	Understand the combustion process of SI engine
CO3	Understand the combustion process of CI engine
CO4	Explore various alternate fuels in IC engine
CO5	Describe emission control technologies of IC engine

Mapping of course outcomes with program outcomes

	PO1	PO2	PO3	PO4	PO5	PO6	PO7	PO8	PO9	PO10	PO11	PO12
CO1	3	2										
CO2	3	1										
CO3	3	1										
CO4	3	2				1	1					
CO5	3	1				1	1					

Assessment Pattern

Bloom Category	Continuous Assessment Tests		End Semester Examination
	1	2	
Remember	10	10	10
Understand	20	20	20
Apply	20	20	70
Analyse			
Evaluate			
Create			

Total Marks	CIE	ESE	ESE Duration
150	50	100	3 hours

Mark distribution:**Continuous Internal Evaluation Pattern:**

Attendance : 10 marks

Continuous Assessment Test (2 numbers) : 25 marks

Assignment/Quiz/Course project : 15 marks

End semester pattern:

There will be two parts; Part A and Part B. Part A contain 10 questions with 2 questions from each module, having 3 marks for each question. Students should answer all questions. Part B contains 2 questions from each module of which student should answer any one. Each question can have maximum 2 sub-divisions and carry 14 marks.

Course Level Assessment Questions:**Course Outcome 1 (CO1):**

1. Explain the different air-fuel ratios required for different operating conditions of a gasoline engine?
2. What are the different air fuel mixtures on which an engine can be operated?
3. Explain the following; 1.Richmixture, 2.Stoichiometric mixture3. Lean mixture.

Course Outcome 2 (CO2):

1. What are the major factors to be considered for the design of SI engine combustion chamber?
2. Define the terms flame development and flame propagation in engines
3. Using the pressure crank angle diagram (P- θ) explain the different stages of desirable combustion in a SI engine .Also explain how abnormal combustion takes place (P- θ) diagram?

Course Outcome 3 (CO3):

1. Briefly explain the thermodynamic analysis of CI engine combustion process.Explain clearly assumption made.
2. Explain the various factors that influence spray penetration in CI engine.
3. What is the effect of EGR in emissions from CI engine?

Course Outcome 4 (CO4):

1. Discuss the salient properties of hydrogen as a fuel.
2. What is the modification to be made in CI engine running on biodiesel? Explain in detail about the use of the biodiesel as fuel in CI engine and various merits and demerits of it use?
3. Explain the fuel characteristics of alcohols,CNG,LPG & hydrogen?

Course Outcome 5 (CO5):

1. List the major pollutants from SI engines. How can we measure and control each of them
2. What are the effects of pollutants from CI engines on environment and human beings? How can these be controlled to a certain extent.
3. Explain soot and particulate traps.

MODEL QUESTION PAPER
APJ ABDUL KALAM TECHNOLOGICAL UNIVERSITY
VI SEMESTER B.TECH DEGREE EXAMINATION
MET342: IC ENGINE COMBUSTION AND POLLUTION

Maximum: 100 Marks**Duration: 3 hours****PART A**

Answer all questions, each question carries 3 marks

1. What are the different air fuel mixtures on which an engine can be operated?
2. Why a SI engine requires a rich mixture during idling and at full load?
3. What are factors that influence the flame speed?
4. What are the various factors affecting knock in spark ignition engine?
5. State briefly about air motion in CI engines using diagrams.
6. What is the effect of delay period on Knock in CI engines?
7. List the components present in the measuring chain for pressure measurement in engine research.
8. Write about the different types of alternate fuels available.
9. What are the various pollutants present in combustion products?
10. What are emission norms? Give the major pollutants that are to be controlled?

(10 X 3 = 30 marks)

PART B

Answer one full question from each module

Module 1

11. Briefly explain the different air-fuel ratios required for different operating conditions of a gasoline engine? (14 marks)
12. Discuss the air fuel ratio requirements of SI engine? (14 marks)

Module 2

13. Explain the stages of combustion in SI engines with suitable flame propagation curve? (14 marks)
14. What is meant by abnormal combustion. Explain the phenomena of knock in SI engine? (14 marks)

Module 3

15. Explain with figures various types of combustion chambers used in CI engine. (14 marks)
16. Explain the phenomenon of spray evaporation and combustion in CI engine (14 marks)

Module 4

17. Explain the fuel characteristics of biodiesel, CNG,LPG &hydrogen? (14 marks)
18. Discuss about the HCCI engine. (14 marks)

Module 5

19. Write short notes on the formation of particulate and smooth emission in IC engines? (14 marks)
20. Explain in detail about the different methods used for the measurement of exhaust Emission in petrol engine? (14 marks)

Syllabus**Module 1**

Engine design and operating parameters, Thermo chemistry of fuel-air mixtures
Properties of working fluids- unburned mixture composition, burned mixture charts, Exhaust gas composition.

Module 2

Ideal models of engine cycles, Availability analysis of engine processes. Combustion in SI engines- Thermodynamic analysis, Flame structure and speed, Cyclic variations in combustion, partial burning and misfire, abnormal combustion

Module 3

Combustion in CI engines- Phenomenological model of CI engine combustion, Analysis of cylinder pressure data, fuel spray behaviour

Module 4

Utilization of alternate fuels in IC engines- biodiesel, hydrogen, LPG, Natural gas- Advantages and disadvantages- HCCI combustion, ASTM specifications

Module 5

Engine emission and air pollution- Genesis and formation of pollutants, SI engine emission control technology - CI engine emission control technology, fuel quality, emission standards

Text Books:

1. Ganesan, Internal combustion engines, Tata- Mcgraw Hill Publishers, 2002
2. Ramalingam, K.K., Internal Combustion Engines, Scitech Publications (India) Pvt. Ltd., 2004.
3. F Obert, IC Engines and air pollution, Intext educational publishers, 1973
4. Mathur,M.L., and Sharma,R.P., A Course in Internal Combustion Engines, DhanpatRai Publications, 1993.

Reference Books:

1. Heywood JB, IC Engine fundamentals, McGraw hill book Co, 1989
2. W WPulkrabek, Engineering Fundamentals of the IC Engine, 2nd edition, PHI, 2003
3. B. P. Pundir, Engine Emissions: Pollutant formation and advances in control technology, NarosaPublication,2007

Course Contents and Lecture Schedule

No.	Topic	No. of Lectures
1		
1.1	Engine design and operating parameters, Thermo chemistry offuel-air mixtures	4
1.21.2	Properties of working fluids- unburned mixture composition, burned mixture charts, Exhaust gas composition.	3
2	Combustion in SI engines	
2.1	Ideal models of engine cycles, Availability analysis of engine processes.	2
2.2	Thermodynamic analysis, Flame structureand speed, Cyclic variations in combustion, partial burning and misfire,abnormal combustion	5
3	Combustion in CI engines	
3.1	Phenomenological model of CI engine combustion	4
3.2	Analysis of cylinder pressure data, fuel spray behavior	3
4	Utilization of alternate fuels in IC engines	
4.1	Biodiesel, hydrogen, LPG,Natural gas- Advantages and disadvantages	5
4.2	HCCI combustion, ASTMspecifications	2
5	Engine emission and air pollution	
5.1	Genesis and formation of pollutants	1

5.2	SI engine emission control technology	3
5.3	CI engine emission control technology, fuel quality, emission standards	3

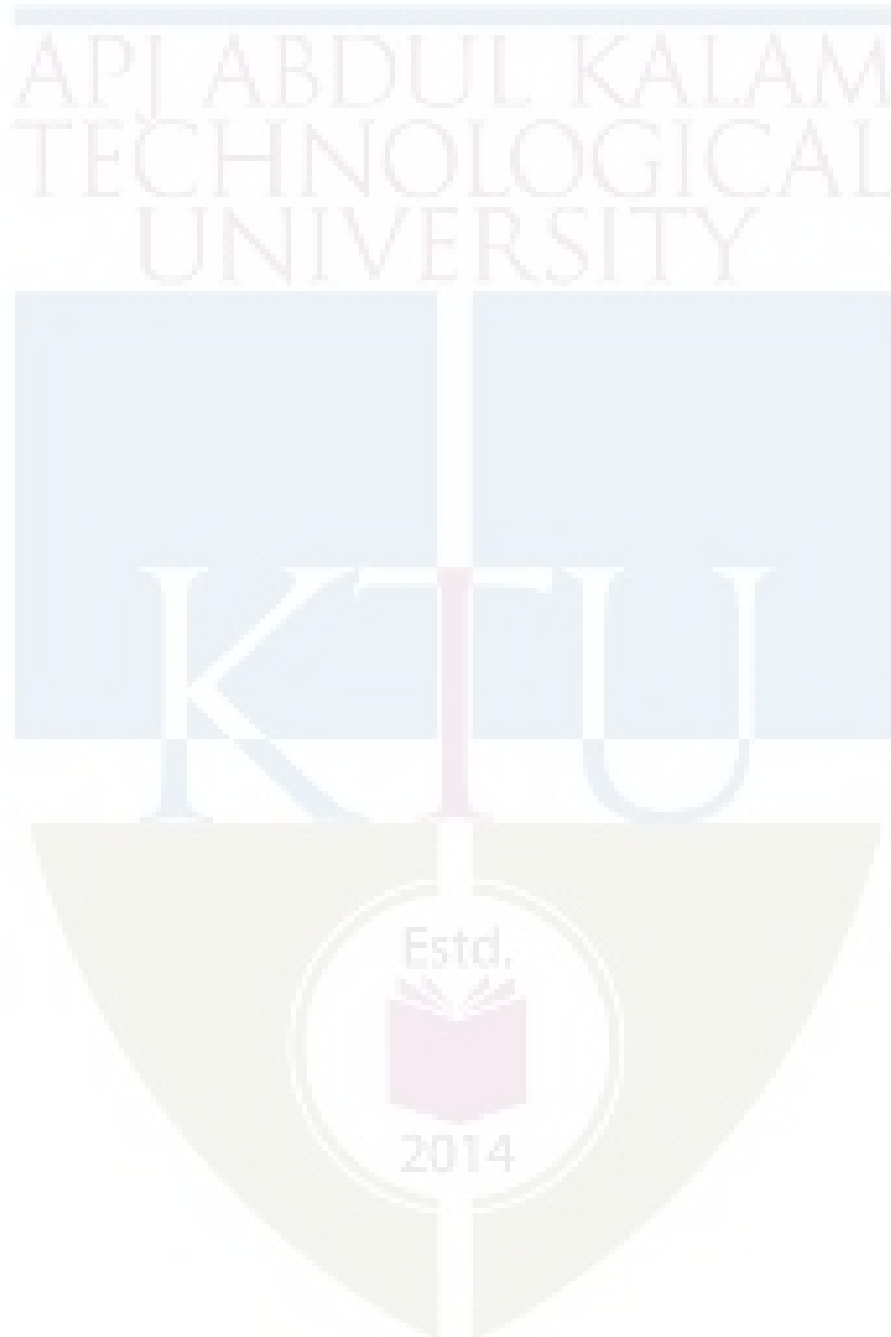

CODE	COURSE NAME	CATEGORY	L	T	P	CREDIT
MET 352	AUTOMOBILE ENGINEERING	PEC	2	1	0	3

Preamble:

The objective of this course is

- To know the anatomy of automobile in general
- To understand the working of different automotive systems and subsystems
- To update the latest developments in automobiles

Prerequisite: EST 120 Basics of Mechanical Engineering

Course Outcomes: After the completion of the course the student will be able to

CO 1	Explain different automotive systems and subsystems .
CO 2	Illustrate the principles of transmission, suspension, steering and braking systems of an automobile.
CO 3	Build a basic knowledge about the technology in electric vehicles.
CO 4	Summarize the concept of aerodynamics in automobiles.

Mapping of course outcomes with program outcomes

	PO1	PO2	PO3	PO4	PO5	PO6	PO7	PO8	PO9	PO10	PO11	PO12
CO1	3											3
CO2	3											3
CO3	3											3
CO4	3											3

Assessment Pattern

Bloom's Category	Continuous Assessment Tests		End Semester Examination
	1	2	
Remember	10	10	10
Understand	20	20	20
Apply	20	20	70
Analyse			
Evaluate			
Create			

Mark distribution

Total Marks	CIE	ESE	ESE Duration
150	50	100	3 hours

Continuous Internal Evaluation Pattern:

Attendance : 10 marks

Continuous Assessment Test (2 numbers) : 25 marks

Assignment/Quiz/Course project : 15 marks

End Semester Examination Pattern: There will be two parts; Part A and Part B. Part A contain 10 questions with 2 questions from each module, having 3 marks for each question. Students should answer all questions. Part B contains 2 questions from each module of which student should answer any one. Each question can have maximum 2 sub-divisions and carry 14 marks.

Course Level Assessment Questions**Course Outcome 1 (CO1):**

1. What is the need of clutch and gearbox in an automobile?
2. List out the factors affecting the maximum torque transmitting capacity of a friction clutch,
3. Define over drive and list out its advantages.

Course Outcome 2 (CO2)

1. Explain Ackermann steering mechanism with a neat sketch.
2. Explain in detail the working and function of ABS braking system.
3. Explain the function and advantages of Double Wishbone Suspension system.

Course Outcome 3 (CO3):

1. What is the difference between an electric vehicle and a hybrid vehicle?
2. List out the differences in the chassis design of an electric vehicle comparing with the conventional chassis.
3. Explain the basic operation of a fuel cell.

Course Outcome 4 (CO4):

1. What is the significance of aerodynamic lift in vehicles?
2. Explain the concept of 'Hatch back Drag'.
3. What are the functions of negative lift aerofoil wings.

Model Question Paper

MECHANICAL ENGINEERING

SIXTH SEMESTER MECHANICAL ENGINEERING

MET 352 AUTOMOBILE ENGINEERING

Max. Marks: 100

Duration: 3 Hours

PART A (30 marks)

Answer all questions, each carries 3 marks.

1. List the three types of chassis construction.
2. Explain the loads coming on a chassis frame.
3. Differentiate body roll couple and body overturning couple.
4. Explain the features of Double Wish Bone suspension system.
5. Describe any type of a regenerative brake system.
6. Illustrate the desirable properties of brake pad materials.
7. Define the terms under steer and over steer in automobiles.
8. Explain the advantages of power assisted steering system.
9. Explain the functions of negative lift aerofoil wings.
10. List out the advantages of rear end spoiler in a vehicle.

PART B (70 marks)

Answer any one question from each module, each carries 14 marks.

Module 1

11.	a)	Explain the working of worm and roller steering gearbox system with the help of a neat sketch.	(7)
	b)	Explain the common troubles encountered in gear boxes and suggest suitable remedies.	(7)
12.		Compare hydraulic, mechanical, electrical and vacuum methods of operating clutches. Describe a hydraulic operated clutch in detail with help of simple	(14)

		diagram.	
Module 2			
13.	a)	Explain the features of McPherson strut suspension system with a neat sketch.	(8)
	b)	Explain the function of an antiroll bar in a four wheeled vehicle.	(6)
14.	a)	Illustrate the working of swing arm rear wheel drive independent suspension.	(8)
	b)	Explain the features of De Dion axle rear wheel suspension.	(6)
Module 3			
15.	a)	Explain how the braking efficiency of a vehicle is evaluated? Also detail the parameters that affect the braking efficiency.	(7)
	b)	Derive an expression for the brakes applied on front and rear wheels.	(7)
16.	a)	Discuss the working and advantages of ABS over conventional systems.	(8)
	b)	Explain the working of a brake caliper with a neat sketch.	(6)
Module 4			
17.	a)	Explain the working and advantages of turbocharger with a neat sketch.	(8)
	b)	Explain how oil control ring helps in piston lubrication.	(6)
18.	a)	Explain the basic principle of a hydrogen fuel cell and its efficiency.	(8)
	b)	Explain the technology of high speed electric trains.	(6)
Module 5			
19.	a)	Differentiate between fast back drag and hatch back drag.	(7)
	b)	Explain the methods to control the aerodynamic lift in vehicles.	(7)
20.	a)	Illustrate the influence of shape of vehicles on drag coefficients.	(7)
	b)	Explain how profile edge chamfering improves drag in vehicles.	(7)

Syllabus

Module 1

Components of an automobile. General classification. Conventional Chassis construction- Types of frames- Frameless constructions. Vehicle dimensions.

Friction clutch: Principle, dry friction clutches- Pull type diaphragm clutch, multiple diaphragm clutch, multi-plate hydraulically operated automatic transmission clutch, semi centrifugal clutch, fully automatic centrifugal clutch, and integral single plate diaphragm clutch. Electromagnetic clutch operation. Clutch friction materials, wet clutch.

Manual transmission- Need of gear box, power to weight ratio, speed operating range-five speed and reverse sliding mesh, constant mesh, and synchromesh gear boxes. Automatic transmission- Epicyclic gear box - torque convertor – Over drives. Automated manual transmission.

Module 2

Suspension: - suspension geometry, terminology- Macpherson strut friction and spring offset - suspension roll centers:-roll centers, roll axis, roll centre height, short swing and long arm suspension, transverse double wishbone, parallel trailing double arm and vertical pill strut suspension, Macpherson strut suspension, semi-trailing arm rear suspension, telescopic suspension. High load beam axle leaf spring, sprung body roll stability. Rear axle beam suspension- body roll stability analysis:- body roll couple, body roll stiffness, body over turning couple.

Rear suspension: - live rigid axle suspension, non drive rear suspension- swing arm rear wheel drive independent suspension. Low pivot split axle coil spring wheel drive independent suspension, trailing and semi trailing arm rear wheel drive independent suspension. Transverse double link arm rear wheel drive independent suspension, De Dion axle rear wheel suspension - Hydrogen suspension, hydro-pneumatic automatic height correction suspension.

Module 3

Brakes: mechanical and hydraulic brakes (review only) – properties of friction lining and pad materials, theory of internal shoe brake, equations –effect of expanding mechanism of shoes on total braking torque, equations. Braking of vehicles:- brakes applied on rear, front and all four wheels, equations –calculation of mean lining pressure and heat generation during braking operation, equations. – braking of vehicle moving on curved path, simple problems.

Anti Lock Braking system (ABS):- hydro-mechanical ABS - hydro-electric ABS - air-electric ABS. Brake servos: - direct acting suspended vacuum assisted brake servo unit operation - hydraulic servo assisted brake systems. Pneumatic operated disc brakes – electronic-pneumatic brakes. Regenerative braking system.

Module 4

Steering:-basic principle of a steering system– Ackermann –over steer and under steer – slip angle, camber, , king pin inclination, caster, toe-in and toe-out .Steering gear box:-worm and roller type steering gear box – Re-circulating ball nut and rocker lever– need of power assisted steering.

Piston for IC engine, piston rings, piston pin, connecting rod, crank shaft, crank pin, cam shaft, valves, fly wheel, fluctuation of energy and size of fly wheel, hub and arms, stress in a fly wheel rim, simple problems. Fuel injection systems: multiport fuel injection (MPFI) and common rail direct injection (CRDI) systems. Super charging in engines, turbo charger, turbo lag.

Electric Vehicle Technology (EVT): EV Architecture, types of batteries, battery parameters, super capacitors. Fuel cells and its efficiency. EV Chassis – requirements, suspension for EVs. Recent Electric vehicles- Electric mobility aids. Future of electric vehicles –Tesla S, Maglev trains, Electric rail road systems.

Module 5

Aerodynamic drag: pressure drag, air resistance, opposing motion of a vehicle, equations, after flow wake, drag coefficients, various body shapes, base drag, vortices, trailing vortex drag, attached transverse vortices. Aerodynamic lift:-lift coefficients, vehicle lift, underbody floor height versus aerodynamic lift and drag, aerofoil lift and drag, front end nose shape.

Car body drag reduction:-profile edge chamfering, bonnet slope and wind screen rake, roof and side panel chamfering, rear side panel taper, under body rear end upward taper, rear end tail extension, under body roughness. Aerodynamic lift control:- under body dams, exposed wheel air flow pattern, partial enclosed wheel air flow pattern, rear end spoiler, negative lift aerofoil wings. After body drag: - square back drag, fast back drag, hatch back drag, notch back drag.

Text Books

1. Heinz Heisler, Vehicle and engine technology, Butterworth-Heinemann, 2nd edition,1998.
2. R.B. Gupta., Auto design , Satya Prakashan Publishers, New Delhi, 2016 .
3. James Larminie and John Lowry, Electric vehicle technology explained, Wiley publications, 2nd edition, 2015.
4. Kirpal Singh, Automobile Engineering Vol.1 & Vol.2, Standard Publishers, 13th edition, 2020.

Reference Books

4. V.A.W. Hillier, Fundamentals of modern vehicle technology, Butterworth-Heinemann, 2nd edition,1998.

5. Tom Denton, Electric and Hybrid Vehicles, Routledge Publishers, 2nd edition, 2020.

Course Contents and Lecture Schedule

No	Topic	No. of Lectures
1	Clutch and transmission	
1.1	Introduction, Chassis construction- Types of frames.	1
1.2	Frameless construction, Vehicle dimensions	1
1.3	Principle of dry friction clutches- Single plate, Multi plate.	1
1.4	Semi centrifugal clutch, fully automatic centrifugal clutch, and	1
1.5	Integral single plate diaphragm clutch. Electromagnetic clutch operation., clutch friction materials, wet clutches	1
1.6	Sliding mesh, constant mesh , synchromesh gear boxes, epicyclic gear boxes	1
1.7	Torque converter, Over drives, Automated manual transmission	1
2	Suspension	
2.1	Suspension: - suspension geometry, terminology. Macpherson strut friction and spring offset.	1
2.2	Suspension roll centers:-roll centers, roll axis, roll centre height, short swing and long arm suspension.	1
2.3	Transverse double wishbone, parallel trailing double arm and vertical pill strut suspension, Macpherson strut suspension, semi-trailing arm rear suspension, telescopic suspension.	1
2.4	High load beam axle leaf spring, sprung body roll stability. Rear axle beam suspension- body roll stability analysis:- body roll couple, body roll stiffness, body over turning couple.	1
2.5	Rear suspension: - live rigid axle suspension, non drive rear suspension- swing arm rear wheel drive independent suspension.	1
2.6	Low pivot split axle coil spring wheel drive independent suspension, trailing and semi trailing arm rear wheel drive independent suspension.	1
2.7	Transverse double link arm rear wheel drive independent suspension, De Dion axle rear wheel suspension. Hydrogen suspension, hydro-pneumatic automatic height correction suspension.	1
3	Brakes	
3.1	Types of Brakes, Properties of friction lining and pad materials.Theory	1

	of internal shoe brake, equations	
3.2	Effect of expanding mechanism of shoes on total braking torque, equations.	1
3.3	Braking of vehicles:- brakes applied on rear, front and all four wheels, equations.	1
3.4	Calculation of mean lining pressure and heat generation during braking operation, equations.	1
3.5	Braking of vehicle moving on curved path, simple problems. Hydro-mechanical ABS - hydro-electric ABS	1
3.6	Air-electric ABS. Brake servos: -direct acting suspended vacuum assisted brake servo unit operation - Hydraulic servo assisted brake systems.	1
3.7	Pneumatic operated disc brakes – electronic-pneumatic brakes. Regenerative braking systems.	1
4 Steering, Engine and EVT		
4.1	Ackermann steering mechanism, over steer and under steer .	1
4.2	Worm and roller type steering gear box, Re-circulating ball nut and rocker lever, power assisted steering.	1
4.3	IC engines, piston, rings, pin, flywheel, connecting rod.Crank shaft, crank pin, cam shaft, valve mechanism	1
4.4	Fuel injection systems ,Turbochargers, turbo lag.	1
4.5	EV Architecture, types of batteries, battery parameters, super capacitors. Fuel cells and its efficiency.	1
4.6	EV Chassis – requirements, suspension for EVs. Recent Electric vehicles- Electric mobility aids.	1
4.7	Future of electric vehicles –Tesla S, Maglev trains, Electric rail road systems.	1
5 Aerodynamics in automobiles		
5.1	Aerodynamic drag: pressure drag, air resistance, opposing motion of a vehicle.	1
5.2	Flow wake, drag coefficients, various body shapes, base drag, vortices, trailing vortex drag, attached transverse vortices.	1
5.3	Aerodynamic lift:-lift coefficients, vehicle lift. Under body floor height versus aerodynamic lift and drag.Aerofoil lift and drag, front end nose	1

	shape.	
5.4	Car body drag reduction:-profile edge chamfering, bonnet slope and wind screen rake.	1
5.5	Roof and side panel chamfering, rear side panel taper, under body rear end upward taper, rear end tail extension, under body roughness.	1
5.6	Aerodynamic lift control:- under body dams, exposed wheel air flow pattern, partial enclosed wheel air flow pattern, rear end spoiler, negative lift aerofoil wings.	1
5.7	After body drag: - square back drag, fast back drag, hatch back drag, notch back drag.	1

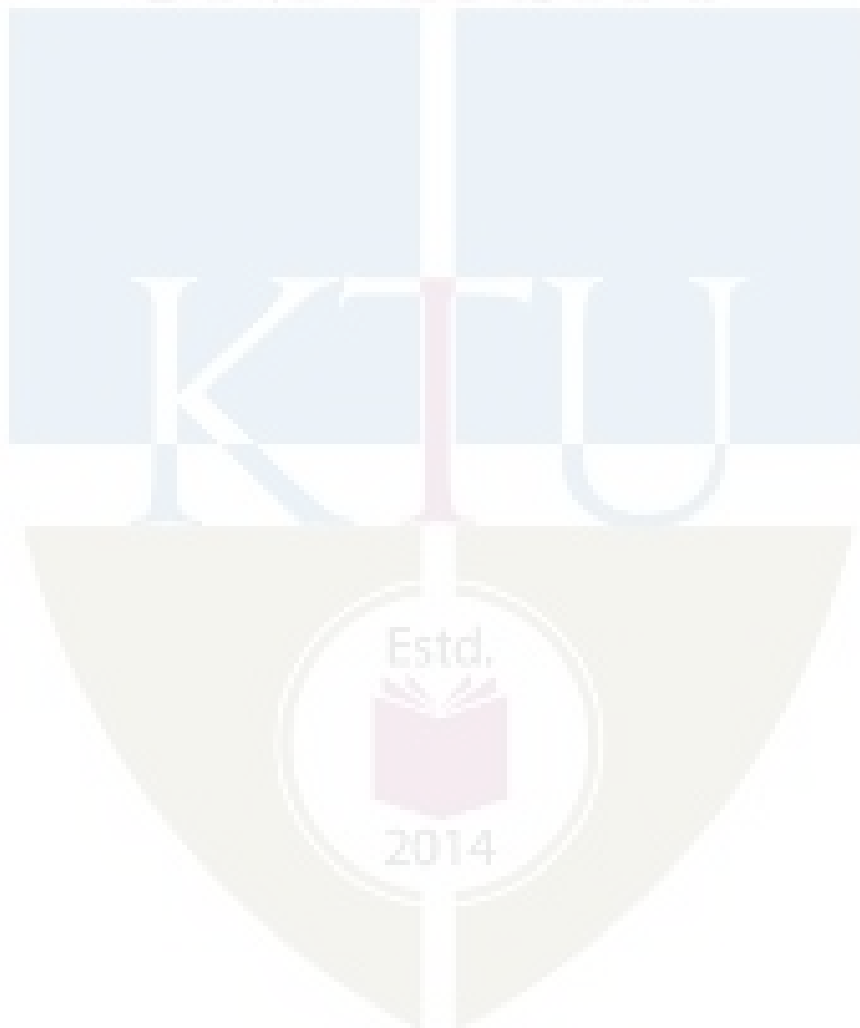

CODE MET362	COURSE NAME PRODUCT DESIGN AND DEVELOPMENT	CATEGORY	L	T	P	CREDIT
		PEC	2	1	0	3

Preamble:

- To create confidence in developing new products.
- To acquaint with methods and tools for product design and development.
- To equip with practical knowledge in conceptualization, design and development of new product.

Prerequisite: NIL

Course Outcomes: After the completion of the course the student will be able to

CO 1	Determine the life cycle of a product and product development process
CO 2	Develop knowledge of robust design and conceptual design
CO 3	Introduce the concept of Design for Manufacturing and Assembly in product design.
CO 4	Use value engineering in the development of product
CO 5	Incorporate ergonomics and rapid prototyping in product development.

Mapping of course outcomes with program outcomes

	PO 1	PO 2	PO 3	PO 4	PO 5	PO 6	PO 7	PO 8	PO 9	PO 10	PO 11	PO 12
CO 1	3	3	2									
CO 2	3	3	2									
CO 3	3	3	2									
CO 4	3	3	2									
CO 5	3	3	2									

Assessment Pattern

Bloom's Category	Continuous Assessment Tests		End Semester Examination
	1	2	
Remember	10	10	10
Understand	20	20	20
Apply	20	20	70
Analyse			
Evaluate			
Create			

Mark distribution

Total Marks	CIE	ESE	ESE Duration
150	50	100	3 hours

Continuous Internal Evaluation Pattern:

Attendance	: 10 marks
Continuous Assessment Test (2 numbers)	: 25 marks
Assignment/Quiz/Course project	: 15 marks

End Semester Examination Pattern: There will be two parts; Part A and Part B. Part A contain 10 questions with 2 questions from each module, having 3 marks for each question. Students should answer all questions. Part B contains 2 questions from each module of which student should answer any one. Each question can have maximum 2 sub-divisions and carry 14 marks.

Course Level Assessment Questions**Course Outcome 1 (CO1):**

1. State the features of a good product design.
2. Explain the morphology of design.
3. Describe about the product life cycle.

Course Outcome 2 (CO2)

1. Discuss the brainstorming technique.
2. Discuss about the robust design.
3. Describe the industrial design process.

Course Outcome 3(CO3):

1. Explain DFM Method in design.
2. Explain the importance of ergonomics in product design.
3. Explain the environmental impacts derived from the manufacturing sector.

Course Outcome 4 (CO4):

1. Discuss the advantages of value analysis.
2. Compare Value analysis and value engineering.
3. Discuss some of the quantitative economic analysis tool used in industry.

Course Outcome 5 (CO5):

1. Describe the steps in reverse engineering.
2. Explain the concept of Concurrent Engineering, Rapid prototyping
3. Explain about the patenting system.

MODEL QUESTION PAPER

**APJ ABDUL KALAM TECHNOLOGICAL UNIVERSITY
SIXTH SEMESTER B. TECH DEGREE EXAMINATION
Course Code: MET362**

Course Name: PRODUCT DESIGN AND DEVELOPMENT

Max. Marks: 100

Duration: 3 Hours

PART – A

(ANSWER ALL QUESTIONS, EACH QUESTION CARRIES 3 MARKS)

1. How the different types of products are classified?
2. What are the various reasons for the failure of a new product?
3. What are three accuracy points in cam and follower synthesis?
4. What meant by the term “lines of maintenance”?
5. Analyze the corporate social responsibility in ethical view point?
6. Differentiate between fixed cost and variable cost?
7. Explain the term anthropometry?
8. What are the rights of a patentee?
9. Differentiate between drafting and modelling software with suitable examples?
10. Explain different steps in a 3d scanning process

PART – B

(ANSWER ONE FULL QUESTION FROM EACH MODULE)

Module 1

11. Explain the various steps involved the morphology of design? (14 marks)
12. Analyze the steps and responsibilities involved in the development of a new product with the help of an example? (14 marks)

Module 2

13. Discuss the various steps in robust design process? (14 marks)
14. Analyze the various activities involved in the industrial design process? (14marks)

Module 3

15. a) Elaborate the role of ergonomic factors in product design? (8 marks)
- b) Analyze the ergonomic factors that need to be considered in the design of a chair? (6 marks)

16. Explain how the design for assembly affects the product design with the help of two examples?

(14 marks)

Module 4

17. Define Value Engineering. Explain the application of the value engineering concept with the help of two case studies?

(14 marks)

18. How the cost of a product is determined? Explain with suitable example.

(14 marks)

Module 5

19. Analyze the major factors that contribute to the improved product quality by incorporating the concurrent engineering concept?

(14 marks)

20. Explain Stereo-lithography and Fused Deposition Modeling with sketch. Compare the advantages and disadvantages of these techniques?

(14 marks)

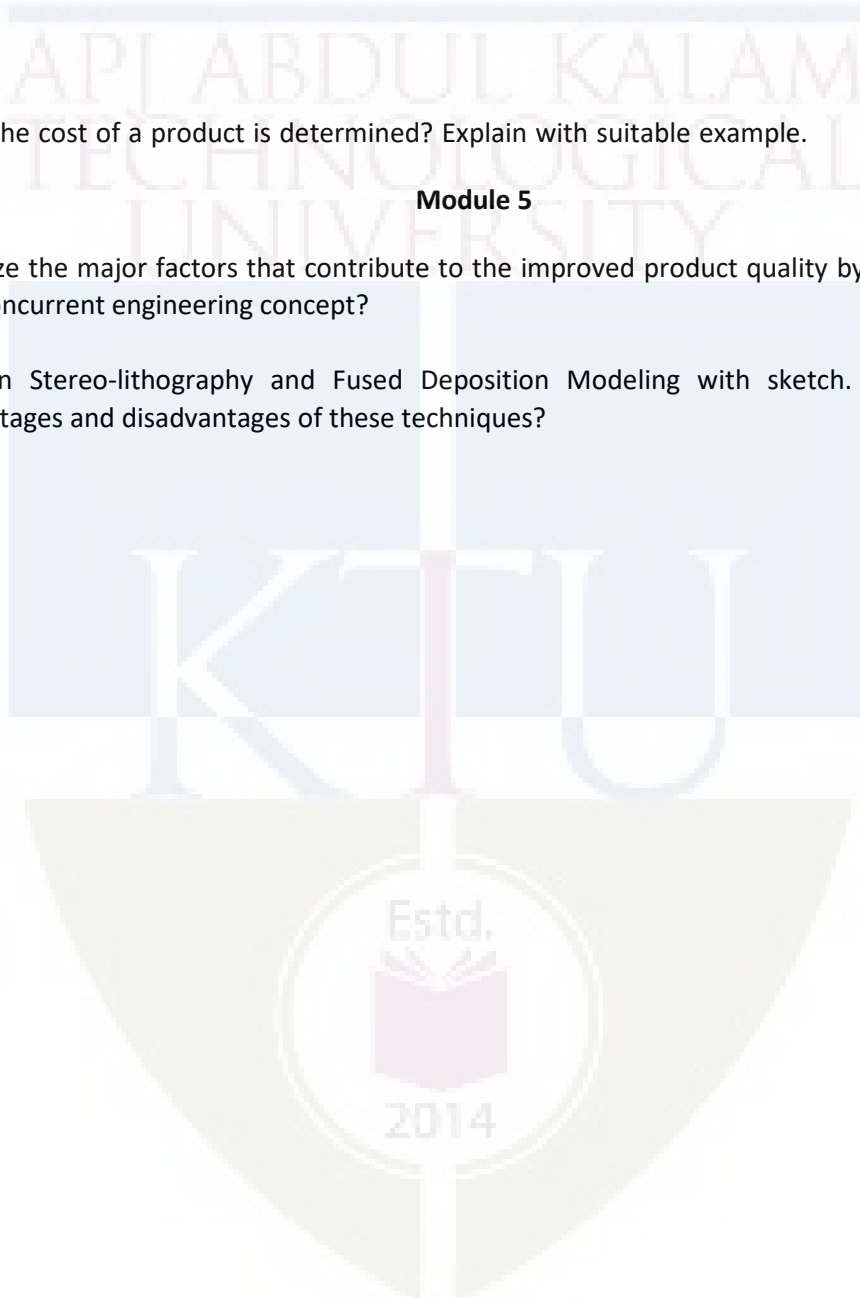

Module 1

Introduction: Classification/ Specifications of Products, Product life cycle, product mix.

Introduction to product design, Modern product development process Design by evolution, Design by innovation, Morphology of design

Ethics in product design, legal factors and social issues.

Module 2

Creativity Techniques: Creative thinking, conceptualization, brain storming, primary design, drawing, simulation, detail design.

Conceptual Design: Generation, selection & embodiment of concept, Product architecture.

Industrial design: process, need.

Robust Design: Taguchi Designs, Design of experiments.

Module 3

Design for Manufacturing and Assembly: Methods of designing for Manufacturing and Assembly.

Design for Maintenance. Design for Environment.

Ergonomics in product design.

Aesthetics in product design. Concepts of size and texture color.

Module 4

Value Engineering / Value Analysis: Definition. Methodology, Case studies.

Product costing.

Economic analysis: Qualitative & Quantitative.

Psychological and Physiological considerations.

Module 5

Concurrent Engineering -Elements of concurrent engineering, Benefits

Rapid prototyping: concepts, processes and advantages.

Reverse engineering: steps in reverse engineering- hardware and software in reverse engineering

Tools for product design – Drafting / Modeling software.

Patents & IP Acts- Overview, Disclosure preparation.

Text Books

MECHANICAL ENGINEERING

1. Karl T Ulrich, Steven D Eppinger, “Product Design & Development.” Tata McGraw Hill, 2003.

Reference Books

1. Baldwin E N & Neibel B W “Designing for Production.” Edwin Homewood Illinois.

2. Bralla J G (Ed.), “Handbook of Product Design for Manufacture, McGraw Hill, New York, 1986

3. D. T. Pham, S.S. Dimov, Rapid Manufacturing-The Technologies and Applications of Rapid Prototyping and Rapid Tooling, Springer – Verlag, London, 2001.

4. David G Ullman, “The Mechanical Design Process.” McGraw Hill Inc Singapore 1992

5. Hollins B & Pugh S “Successful Product Design.” Butter worths London, 1990

6. Jones J C “Design Methods.” Seeds of Human Futures. John Willey, 1970

7. Kevin Otto & Kristin Wood Product Design: “Techniques in Reverse Engineering and new Product Development.”, Pearson Education New Delhi, 2000

8. N J M Roozenberg , J Ekels , N F M Roozenberg “ Product Design Fundamentals and Methods .” John Willey & Sons 1995.

9. Andreas Gebhardt, Rapid Prototyping, Carl Hanser – Verlag, Munich, 2003.



Course Contents and Lecture Schedule

MECHANICAL ENGINEERING

No	Topic	No. of Lectures
1	Module 1	6
1.1	Introduction: Classification/ Specifications of Products. Product life cycle.	2
1.2	Product mix. Introduction to product design. Modern product development process.	2
1.3	Innovative thinking. Morphology of design. Ethics in product design Ethics in product design	2
2	Module 2	6
2.1	Creativity Techniques, Conceptual Design: Generation, selection & embodiment of concept.	2
2.2	Product architecture. Industrial design: process, need.	2
2.3	Robust Design: Taguchi Designs & DOE.	2
3	Module 3	7
3.1	Design for Manufacturing and Assembly: Methods of designing for Manufacturing and Assembly.	3
3.2	Designs for Maintainability. Designs for Environment. Product costing.	2
3.3	Ergonomics in product design. Aesthetics in product design.	2
4	Module 4	7
4.1	Value Engineering / Value Analysis: Definition. Methodology,	3
4.2	Case studies.	2
4.3	Economic analysis: Qualitative & Quantitative. Product costing.	2
5	Module 5	9
5.1	Concurrent Engineering, Rapid prototyping: concepts, processes and advantages.	3
5.2	Reverse engineering: steps in reverse engineering- hardware and software in reverse engineering	2
5.3	Tools for product design – Drafting / Modelling software.	2
5.4	Patents & IP Acts. Overview, Disclosure preparation.	2

Estd.



2014

CODE	ADVANCED METAL JOINING TECHNIQUES	CATEGORY	L	T	P	Credits
MET372		PEC	2	1	0	3

Preamble:

This course provides student to learn fundamental concepts of advanced welding techniques and their applications to an extent to enable the learner to arrive at a firsthand conclusion on selection of a particular technique best suited to resolve a metal joining problem.

Prerequisite: MET204 Manufacturing process.

Course Outcomes: After the completion of the course the student will be able to:

CO 1	Explain the physics, equipment, applications of EBW and LBW.
CO 2	Summarise the physics, equipment, applications of diffusion welding and adhesive bonding processes.
CO 3	Contrast the physics, equipment, applications of explosive welding with friction welding.
CO 4	Outline the physics, equipment, applications of ultrasonic welding and brazing.
CO 5	Illustrate the physics, equipment, applications of plasma arc welding and magnetically impelled arc butt welding.
CO 6	Select an appropriate welding technique to resolve a metal joining problem.

Mapping of course outcomes with program outcomes:

	PO 1	PO 2	PO 3	PO 4	PO 5	PO 6	PO 7	PO 8	PO 9	PO 10	PO 11	PO 12
CO 1	3	-	-	-	-	-	-	-	-	-	-	2
CO 2	2	-	-	-	-	-	-	-	-	-	-	2
CO 3	2	-	-	2	-	-	-	-	-	-	-	3
CO 4	3	-	2	-	-	-	-	-	-	-	-	2
CO 5	2	-	-	-	1	-	-	-	-	-	-	2
CO 6	3	-	-	-	2	-	-	-	-	-	-	1

Assessment Pattern

Bloom's Category	Continuous Assessment Tests		End Semester Examination (marks)
	1 (marks)	2 (marks)	
Remember	20	20	40
Understand	20	20	40
Apply	10	10	20
Analyse	-	-	-
Evaluate	-	-	-
Create	-	-	-

Mark distribution

Total Marks	CIE	ESE	ESE Duration
150	50	100	3 hours

Continuous Internal Evaluation Pattern:

Attendance : 10 marks

Continuous Assessment Test (2 numbers) : 25 marks

Assignment/Quiz/Course project : 15 marks

End Semester Examination Pattern: There will be two parts; Part A and Part B. Part A contain 10 questions with 2 questions from each module, having 3 marks for each question. Students should answer all questions. Part B contains 2 questions from each module of which student should answer any one. Each question can have maximum 2 sub-divisions and carry 14 marks.

Course Level Assessment Questions.**Course Outcome 1 (CO1):**

1. Explain principle of operation of Electron Beam Welding.
2. Illustrate a typical EBW gun.
3. List 2 applications of laser beam welding. Identify the inherent process capability of LBM which makes it suitable for above listed applications.

Course Outcome 2 (CO2):

1. With the help of suitable diagrams, describe various stages in diffusion welding process.
2. Describe various diffusion welding methods.
3. Explain the physics of adhesive bonding.

Course Outcome 3 (CO3):

1. With the help of suitable diagram, describe parallel stand-off and angular stand-off.
2. Compare the mechanism of metal joining in explosive welding with that of friction welding. Give one application for each.
3. Show the effect of rotational speed on duration of friction welding.

Course Outcome 4 (CO4):

1. Describe principle of operation of ultrasonic welding.
2. List all design considerations for a brazed joint.

3. Make a note on hand torch brazing.

Course Outcome 5 (CO5):

1. Differentiate transferred and non-transferred plasma arc processes.
2. Sketch and explain a plasma arc welding system.
3. Describe the steps involved in MIAB with appropriate diagrams.

Course Outcome 6 (CO6):

1. Select a welding process which is considered relatively best for underwater welding. Correlate relevant process capability of the selected technique to support your selection.
2. Select a welding process that is considered best for welding stainless steel. Correlate relevant process capability of the selected technique to support your selection.
3. Suggest a best welding technique to join materials having thin sections. Explain why.

Model Question Paper
SIXTH SEMESTER MECHANICAL ENGINEERING
MET372 ADVANCED METAL JOINING TECHNIQUES

Max. Marks: 100

Duration: 3 hours

Part–A

Answer all questions. Each question carries 3 marks.

1. Draw typical joint designs for electron beam welding.
2. How do you define “f number” for a laser beam?
3. What is vacuum fusion bonding?
4. Write a short note on crack extension test performed on adhesive bonds.
5. What is Impact velocity? How critical is it in creating an explosive weld?
6. Sketch and mark a simple friction welding setup.
7. What is principle of operation of ultrasonic welding?
8. List down essential properties of brazing filler metals.
9. What is “keyholing” in plasma arc welding?
10. What are the advantages of magnetically impelled arc butt welding?

Part–B

Answer one full question from each module.

Module I

11. (a) Draw and explain an EBW equipment. (7 marks)
(b) Discuss all joint configurations commonly used for LBW. (7 marks)

12. (a) Discuss process characteristics of EBW. (7 marks)

(b) Discuss Carbon Dioxide lasers used for welding. (7 marks)

MECHANICAL ENGINEERING

Module II

13. Explain the theory of diffusion welding process. (14 marks)

14. Classify adhesives used for adhesive bonding and explain their characteristics. (14 marks)

Module III

15. With the help of a neat diagram describe different stages in explosion welding. (14 marks)

16. Draw and explain various joint designs employed in friction welding. (14 marks)

Module IV

17. State and explain all variables in ultrasonic welding. (14 marks)

18. Write short notes on (i) torch brazing (ii) furnace brazing (iii) vacuum brazing (14 marks)

Module V

19. Explain the principle of operation of MIAB welding and steps involved in it with the help of suitable diagrams. (14 marks)

20. Describe the components of a Plasma Arc Welding system and list all applications of PAW. (14 marks)

Syllabus

Module 1

Radiant energy welding: Electron Beam Welding (EBW) - principle and theory- equipment and systems- process characteristics and variables- weld joint design- applications- EBW process variants. Laser Beam Welding-principle and theory-operation-types of lasers-process variables and characteristics-applications.

Module 2

Diffusion welding-principle and theory-methods- welding parameters-advantages and limitations-applications. Cold pressure welding-process, equipment and set-up-applications. Adhesive Bonding-principle and theory-types of adhesives-joint design-bonding methods- applications.

Module 3

Explosive welding-principle and theory-process variables-equipment-joint design-advantages and limitations-applications. Friction welding-principle and theory-process variables-advantages and limitations-applications. Friction stir welding- metal flow phenomena-tools-process variables – applications.

Module 4

Ultrasonic welding-principle and theory-process variables and equipment-types of ultrasonic welds-advantages and limitations-applications. Brazing- principle- brazing processes-torch brazing- furnace brazing- vacuum brazing-induction brazing-advantages and limitations-applications.

Module 5

Plasma arc welding –principle and theory- transferred arc and non-transferred arc techniques-equipment-advantages and limitations-applications. Magnetically impelled arc butt (MIAB) welding-principle of operation-applications. Under water welding-wet and dry under water welding- set-up for underwater welding systems.

Text Books

1. Parmar R.S., Welding Processes and Technology, Khanna Publishers, Delhi, 1998.

Reference Books

1. ASM Metals Handbook “Welding and Brazing”, Vol.6, ASM, Ohio, 1988
2. Parmar R.S., “Welding Engineering and Technology” Khanna Publishers, Delhi, 1997
3. Rossi, B.E., Welding Engineering, Mc Graw-Hill, 1954
4. Schwartz M.M., “Metal Joining Manual”, McGraw-Hill Inc., 1979
5. Udin et al., Welding for Engineers, John Wiley & Sons, New York, 1967
6. Welding Engineers Handbook – ASHE Vol. I, II, III, IV

Course Contents and Lecture Schedule

No.	Topic	No. of Lectures	COs
1.1	Radiant energy welding: Principle of Electron Beam Welding and theory.	1	CO1
1.2	Types of EBW welding guns.	1	CO1
1.3	EBW equipment and systems.	1	CO1
1.4	Process variables –effect of beam current on weld penetration-effect of	1	CO1

	welding speed on weld penetration.		
1.5	Process variants of EBW-medium vacuum EBW and non-vacuum EBW.	1	CO1
1.6	Typical weld joint design and preparation for EBW.	1	CO1
1.7	Weldable materials using EBW and applications of EBW.	1	CO1CO6
1.8	Principle of Laser Beam Welding, mechanism and operation- types of laser systems- process variables and characteristics.	1	CO1
1.9	Weld joint design – weldable materials and applications of laser beam welding.	1	CO1 CO6
2.1	Diffusion welding- principle and theory.	1	CO2
2.2	Diffusion welding methods- Gas-pressure bonding, Vacuum fusion bonding, Eutectic fusion bonding.	1	CO2
2.3	Diffusion welding parameters.	1	CO2
2.4	Weldable materials using diffusion welding- advantages, limitations and applications.	1	CO2 CO6
2.5	Cold pressure welding equipment and set-up-applications.	1	CO2
2.6	Adhesive bonding- principle and theory- classification of adhesives and types of adhesive materials.	1	CO2
2.7	Joint design and bonding methods – applications.	1	CO2 CO6
3.1	Explosive welding- principle and theory- process variables.	1	CO3
3.2	Set-up for explosion welding- Joint design- advantages and limitations- applications.	1	CO3
3.3	Friction welding- principle and theory- process variables.	2	CO3
3.4	Effect of rotational speed on duration of welding- process characteristics.	1	CO3
3.5	Advantages and limitations-applications. Variants of friction welding- friction stir welding-metal flow phenomena.	2	CO3 CO6
4.1	Ultrasonic welding- principle and theory.	1	CO4
4.2	Ultrasonic process variables and equipment-types of ultrasonic welds.	1	CO4
4.3	Advantages and disadvantages of ultrasonic welding- applications.	1	CO4 CO6
4.4	Brazing-principle-brazing processes- torch brazing- furnace brazing- vacuum brazing-induction brazing-advantages and limitations- applications.	2	CO4
5.1	Plasma Arc welding –principle and theory- transferred arc and non-transferred arc processes.	1	CO5
5.2	Plasma arc welding system.	1	CO5
5.3	Advantages, limitations and applications.	1	CO5 CO6
5.4	Magnetically Impelled Arc Butt (MIAB) welding- principle of operation-applications.	2	CO5 CO6
5.5	Under water welding techniques – wet and dry welding- general arrangement for underwater welding systems.	2	CO5

APJ ABDUL KALAM
TECHNOLOGICAL
UNIVERSITY

SEMESTER VI

MINOR



CODE MET382	Course Name MACHINE DESIGN	CATEGORY	L	T	P	CREDIT
		VAC	3	1	0	4

Preamble: This course mainly covers elementary topics of strength of materials such as stresses, strains, stress concentration, etc. Failure theories to predict the failure of machine elements subjected to static and fatigue loading are also covered. Design of bolts, riveted joints, welded joints, springs and shafts are also incorporated in this syllabus.

Prerequisite: EST100 Engineering Mechanics

Course Outcomes: After the completion of the course the student will be able to:

CO 1	To calculate the different types of stresses in a structural member.
CO 2	To apply failure theories and predict the failure of components.
CO 3	To design bolts subjected to fatigue loads.
CO 4	To design riveted and welded joints.
CO 5	To design close coiled helical compression springs and shafts subjected to static and fatigue loads.

Mapping of course outcomes with program outcomes

	PO 1	PO 2	PO 3	PO 4	PO 5	PO 6	PO 7	PO 8	PO 9	PO 10	PO 11	PO 12
CO 1	3	3	2									
CO 2	3	3	2									
CO 3	3	3	2									
CO 4	3	3	2									
CO 5	3	3	2									

Assessment Pattern

Bloom's Category	Continuous Assessment Tests		End Semester Examination
	1	2	
Remember	10	10	10
Understand	20	20	20
Apply	20	20	70
Analyse			
Evaluate			
Create			

Mark distribution

Total Marks	CIE	ESE	ESE Duration
150	50	100	3 hours

Continuous Internal Evaluation Pattern:

Attendance	: 10 marks
Continuous Assessment Test (2 numbers)	: 25 marks
Assignment/Quiz/Course project	: 15 marks

End Semester Examination Pattern: There will be two parts; Part A and Part B. Part A contain 10 questions with 2 questions from each module, having 3 marks for each question. Students should answer all questions. Part B contains 2 questions from each module of which student should answer any one. Each question can have maximum 2 sub-divisions and carry 14 marks.

Course Level Assessment Questions**Course Outcome 1 (CO1):**

1. Define stress concentration factor and factor of safety.
2. Calculate the principal stresses in a structural member subjected to loads in two directions.
3. Draw stress strain diagram and explain its significance in the design of machine elements.
4. Calculate the equivalent stress due to combined axial, bending and torsional loads.

Course Outcome 2 (CO2)

1. Explain the steps in the design process.
2. Distinguish between codes and standards.
3. Describe with neat sketches the different types of fits.
4. What are the different failure theories? What is the significance in design?

Course Outcome 3 (CO3)

1. Define endurance limit. What are the factors affecting it?
2. Explain Soderberg's and Goodman's criteria.
3. Derive an expression for the impact stress in terms of static stress.
4. What is meant by preloading or initial tension in a bolt?
5. Design a bolted joint subjected to eccentric loading.

Course Outcome 4 (CO4):

1. What are the advantages of riveted joint over welded joint?
2. Describe the different modes of failure of a riveted joint.
3. Find the various efficiencies of a riveted joint.

4. Describe the different AWS welding symbols.

MECHANICAL ENGINEERING

5. Design a welded joint subjected to axial loading, twisting moment and bending moment.

Course Outcome 5 (CO5):

1. Design a close coiled helical compression spring subjected to axial loading.
2. Explain surge in spring.
3. What are the different types of end constructions for a close coiled helical compression spring? How do they affect the performance of the spring?
4. What is critical speed of a shaft?
5. Why hollow shafts are preferred in certain applications compared to solid shafts?

MODEL QUESTION PAPER

APJ ABDUL KALAM TECHNOLOGICAL UNIVERSITY

VI SEMESTER BTECH DEGREE EXAMINATION

MET382 : MACHINE DESIGN

Maximum: 100 Marks

Duration:3 hours

PART A

Answer all questions, each question carries 3 marks

1. Define stress concentration and factor of safety.
2. Distinguish between normal stress and principal stress.
3. What are standards and codes?
4. Explain Haigh's and Rankine's theories of failures.
5. Why preloading of bolts is required?
6. Define endurance limit. What is its significance in design of machine elements?
7. Describe the different modes of failure of a riveted joint.
8. Explain with a neat sketch the AWS welding symbols
9. Derive an expression for the stress in a closed coiled helical compression spring.
10. What is meant by the critical speed of a shaft?

PART B

MECHANICAL ENGINEERING

Answer one full question from each module

MODULE 1

11. a) An element in plane stress is subjected to stresses $\sigma_{xx} = 85$ MPa, $\sigma_{yy} = -30$ MPa and $\tau_{xy} = -32$ MPa. Determine the principal stresses and the maximum shear stress (9 marks)
- b) Draw the shear stress, bending stress, axial stress and torsional shear stress in a shaft of circular cross-section. (5 marks)
12. a) Draw the stress-strain diagram for mild steel and show all the significant regions. (5 marks)
- b) Find the maximum stress in the cantilever beam shown below. The material is aluminium. The rod length $L = 15$ cm. The permissible tensile and shear stresses are 70 N/mm² and 50 N/mm² respectively. (10 marks)

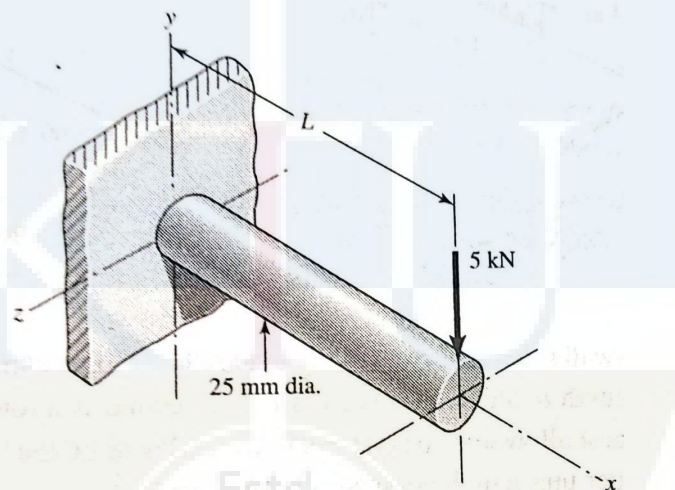

MODULE 2

13. a) Explain allowances and tolerances. (5 marks)
- b) A mild steel shaft having yield stress $\sigma_{yp} = 200$ MPa is subjected to the following stresses. $\sigma_x = 120$ MPa, $\sigma_y = -60$ MPa, $\tau_{xy} = 36$ MPa. Find the factor of safety using
- Rankine's theory
 - Guest's theory
- (10 marks)
14. a) With neat sketches explain clearance fit, interference fit and transition fit. (6 marks)
- b) What are the steps in the design process. (6 marks)
- c) Explain preferred sizes. (2 marks)

MODULE 3

15. a) A round prismatic steel bar ($E = 210 \text{ GPa}$) of length 2 m and diameter 15 mm hangs vertically from a support at its upper end. A sliding collar of mass 20 kg drops from a height of 150 mm onto a flange fixed at the lower end of the bar without rebounding. Calculate the maximum elongation of the bar due to impact. Also, determine the maximum tensile stress in the bar and the corresponding impact factor (10 marks)
- b) Explain the Gerber criterion used in the design for fatigue loading. (4 marks)
16. a) With a neat sketch explain the nominal diameter, root diameter and pitch diameter and pitch of a screw thread. (3 marks)
- b) Find the diameter of the bolt for a bracket loaded as shown below. The allowable shear stress for bolt material is 60 MPa. (11 marks)

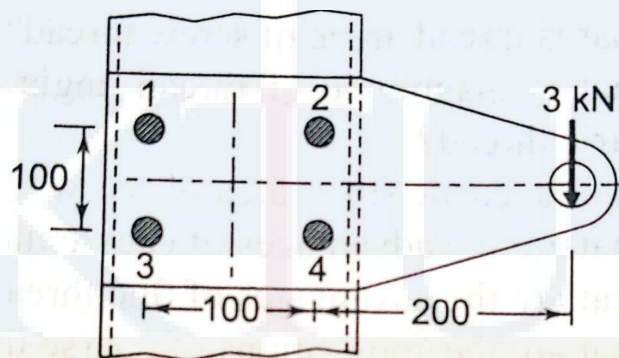
**MODULE 4**

17. a) What are the advantages of welded joint over riveted joint? (9 marks)
- b) Two plates are joined together by means of a single transverse and double parallel fillet welds are shown in figure. The size of the fillet weld is 5 mm and allowable shear load per mm of weld is 330 N. Find the length of each parallel fillet weld. (10 marks)

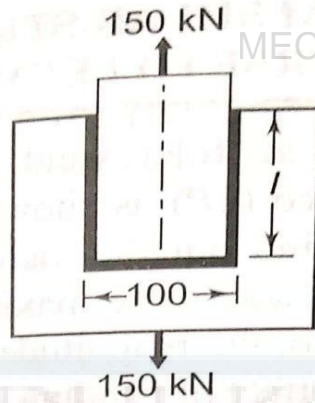

18. a) Draw a zig-zag-double riveted double covered (equal) butt joint and mark all the details. (4 marks)

b) Two flat plates of width $w = 200$ mm, subjected to a tensile force $P = 250$ kN are connected together by means of a double-strap butt joint as shown below. The rivets and the plates are made of the same steel and the permissible stresses in tension, compression and shear are 70 , 100 and 60 N/mm^2 respectively. Calculate the i) diameter of the rivets, ii) thickness of the plates and iv) the efficiency of the joint.

(10 marks)

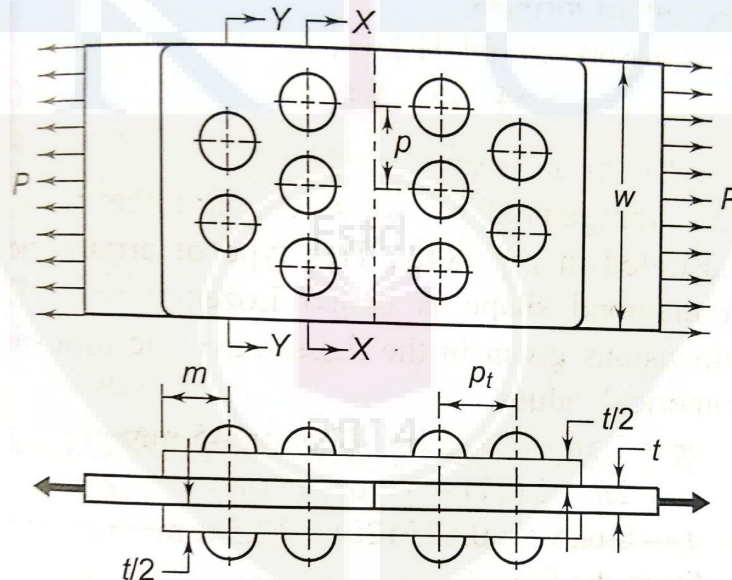

MODULE 5

19. a) Explain surge in springs. (4 marks)

b) It is required to design a helical compression spring subjected to a maximum force of 1250 N. The deflection of the spring corresponding to the maximum force should

be approximately 30 mm. The spring index can be taken as 6. The ultimate tensile strength and modulus of rigidity of the spring material are 1090 and 81370 N/mm² respectively. The permissible shear stress for the spring wire should be taken as 50% of the ultimate tensile strength. Design the spring and calculate: i) wire diameter, ii) mean coil diameter, iii) number of active coils, iv) total number of coils, v) free length of the spring and pitch of the coil. (10 marks)

20. a) A line shaft supporting two pulleys A and B is shown in figure. Power is supplied to the shaft by means of a vertical belt on the pulley A, which is then transmitted to the pulley B carrying a horizontal belt. The ratio of belt tensions on tight and loose sides is 3:1. The limiting value of tension in the belt is 2.7 kN. The permissible shear stress is 86 N/mm². Pulleys are keyed to the shaft. Determine the diameter of the shaft according to the ASME code, if $K_b = 1.5$ and $K_t = 1.0$. (10 marks)

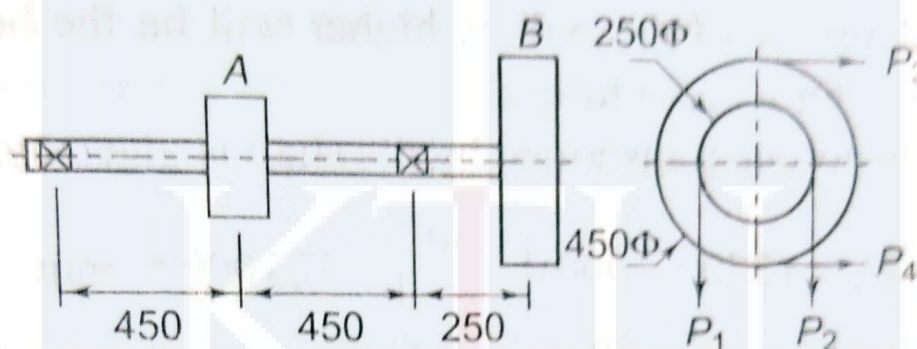

- b) Two shafts ; one solid and the other hollow, have the same weight and transmit the same torque. Calculate the ratio of the maximum shear stress induced in the solid shaft to that in the hollow shaft. The inner diameter of the hollow shaft is 50% of the outer diameter. (5 marks)

Syllabus

MECHANICAL ENGINEERING

Module 1

Tension, compression, shear: Introduction, Internal force, stress, strain, elasticity, stress-strain diagram, working stress, stress concentration, factor of safety, bending and torsional stresses, eccentric loading, stresses due to combined axial, bending and torsional loads, principal stresses

Module 2

Machine design, steps in the design process, standards and codes, preferred sizes, tolerances, allowances, fits, selection of materials

Theories of elastic failures- Guest's theory, Rankine's theory, St. Venant's theory, Haigh's theory, and Von Mises and Hencky Theory.

Module 3

Shock and impact loads, fatigue loading, endurance limit stress, factors affecting endurance limit, design for fatigue loading, Soderberg and Goodman criteria.

Threaded joints, types of threads, stresses in screw threads, bolted joints, initial tension, design of bolts for static and fatigue loading, power screws

Module 4

Design of riveted joints- material for rivets, modes of failure, efficiency of joint, design of boiler and tank joints, structural joints

Design of welded joints- AWS welding symbols, stresses in fillet and butt welds, butt joint in tension, fillet weld in tension, fillet joint under torsion, fillet weld under bending, eccentrically loaded welds.

Module 5

Springs- classification, spring materials, stresses and deflection of helical springs, axial loading, static and fatigue loading, surging, critical frequency, concentric springs, end construction.

Shafting- material, design considerations, causes of failure in shafts, design based on strength, rigidity, critical speed, design for static and fatigue loads, repeated loading, reversed bending

Text Books

1. Bhandari V B, Design of Machine Elements, Tata McGraw-Hill Education, 2010.
2. James M Gere, Mechanics of Materials, Thomson, 2007

Reference Books

1. S P Timoshenko and D H Young, Elements of Strength of Materials, East West Pvt Ltd.,2011
3. Robert L Norton, Design of Machinery, Tata Mc Graw-Hill, 2005
4. P C Sharma and D K Aggarwal, Machine Design, S K Kataria & Sons, 2007.

Course Contents and Lecture Schedule

No	Topic	No. of Lectures (Hrs.)
1		
1.1	Tension, compression, shear-Introduction, internal force, stress, strain, elasticity	3
1.2	Stress-strain diagram, working stress, stress concentration, factor of safety	2
1.3	Bending and torsional stresses, eccentric loading, stresses due to combined axial, bending and torsional loads, principal stresses	3
2		
2.1	Machine design, steps in the design process, standards and codes	3
2.2	Preferred sizes, tolerances, allowances, fits, selection of materials	2
2.3	Theories of elastic failures- Guest's theory, Rankine's theory, St. Venant's theory, Haigh's theory, and Von Mises and Hencky Theory.	3
3		
3.1	Shock and impact loads, fatigue loading, endurance limit stress, factors affecting endurance limit	2
3.2	Design for fatigue loading, Soderberg and Goodman's criteria.	2
3.3	Threaded joints, types of threads, stresses in screw threads, bolted joints, initial tension	2
3.4	Design of bolts for static and fatigue loading, eccentric loading, power screws	2
4		
4.1	Design of riveted joints- material for rivets, modes of failure, rivet and butt joints, efficiency of joint, design of structural joints	3
4.2	Design of welded joints- AWS welding symbols, stresses in fillet and butt welds, Butt joint in tension, fillet weld in tension,	3
4.3	Fillet joint under torsion, fillet weld under bending, eccentrically loaded welds.	3
5		
5.1	Springs- classification, spring materials, stresses and deflection of	3

	helical springs, axial loading	MECHANICAL ENGINEERING
5.2	Static and fatigue loading, surging, critical frequency, concentric springs, end construction	3
5.3	Shafting- material, design considerations, causes of failure in shafts, hollow and solid shafts, design based on strength, rigidity,	3
5.4	Critical speed, design for static and fatigue loads, repeated loading, reversed bending	3

APJ ABDUL KALAM
TECHNOLOGICAL
UNIVERSITY

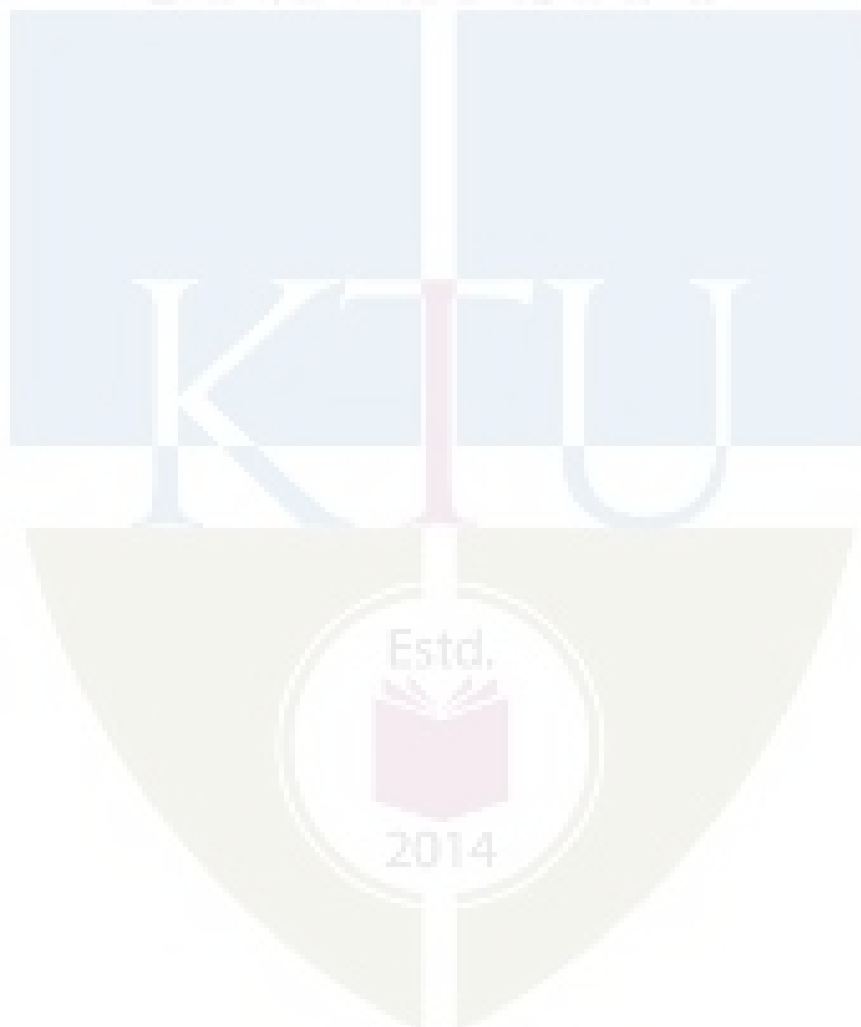

CODE	COURSE NAME	CATEGORY	L	T	P	CREDIT
MET 384	HEAT TRANSFER	VAC	3	1	0	4

Preamble:

The objectives of the course are:

- To introduce the heat transfer by conduction, convection and radiation modes.
- To provide useful information for solving the heat transfer problems across the plane and cylindrical sections
- To give enough ideas to solve the heat transfer problems involving convection heat transfer
- To determine the performance of heat exchangers
- Present and solve the various types of radiation heat transfer problems

Prerequisite: MET203 Mechanics of fluid

Course Outcomes: After the completion of the course the student will be able to

CO 1	To understand the basics of heat transfer.
CO 2	To estimate heat transfer through plane wall, cylindrical surface and fins for various conditions.
CO 3	To solve problems involving heat convection.
CO 4	To solve the problems of heat exchangers and to determine its performance.
CO 5	To estimate radiation heat transfer between two bodies.

Mapping of course outcomes with program outcomes

	PO 1	PO 2	PO 3	PO 4	PO 5	PO 6	PO 7	PO 8	PO 9	PO 10	PO 11	PO 12
CO 1	3											1
CO 2	2	3	2								1	1
CO 3	2	2	2								1	1
CO 4	2	3	2								1	1

Assessment Pattern

Bloom's Category	Continuous Assessment			End Semester Examination
	Assignment (%)	Test 1 (%)	Test 2 (%)	
Remember	30	20	20	10
Understand	30	40	40	20
Apply	40	40	40	70
Analyse				
Evaluate				
Create				

Mark distribution

Total Marks	CIE	ESE	ESE Duration
150	50	100	3 hours

Continuous Internal Evaluation Pattern:

Attendance	: 10 marks
Continuous Assessment Test (2 numbers)	: 25 marks
Assignment/Quiz/Course project	: 15 marks

End Semester Examination Pattern: There will be two parts; Part A and Part B. Part A contain 10 questions with 2 questions from each module, having 3 marks for each question. Students should answer all questions. Part B contains 2 questions from each module of which student should answer any one. Each question can have maximum 2 sub-divisions and carry 14 marks.

Course Level Assessment Questions

Course Outcome 1 (CO1):

1. Explain Fourier's law of heat conduction?
2. Derive the equation of general heat conduction equation in Cartesian coordinates?

Course Outcome 2 (CO2)

1. The interior temperature of a refrigerator is maintained at 7°C . The walls are constructed with two mild steel sheets 3 mm thick with 5 cm of glass wool insulation between them. The heat transfer coefficients on inner and outer surface of refrigerator are $10 \text{ W/m}^2\text{C}$ and $12.5 \text{ W/m}^2\text{C}$ respectively. Find the rate of heat leaked the refrigerator in watts when it is kept in a kitchen room. Also find inter wall temperatures. The temperature in kitchen room is 28°C . Take K (mild steel) = $40 \text{ W/m}\text{-}^{\circ}\text{C}$ K (glass wool) = $0.04 \text{ W/m}\text{-}^{\circ}\text{C}$. Demonstrate the operation of stack and stack pointer through push and pop Instructions.
2. Derive an equation for one dimensional heat conduction through a plane wall and represent it in a form of electrical analogy?

Course Outcome 3(CO3):

1. Explain Newton's law of convective heat transfer?
2. Explain hydrodynamic boundary layer with the help of a neat diagram.
3. Define Reynolds Number, Prandtl Number and Nusselt Number.

Course Outcome 4 (CO4):

1. What is LMTD? What is the need of determine the LMTD?
2. In a double pipe heat exchanger hot water flows at a rate of 14 kg/s and gets cooled from 370K to 340K. At the same time 14 kg/s of cooling water at 303K enters the heat exchanger. The flow conditions are such that overall heat transfer coefficient remains constant at 2270

W/m² K. Determine the effectiveness and the heat transfer area required, assuming two streams are in parallel flow. Assume the specific heat for the both the streams = 4.2 kJ/kg K.

Course Outcome 5 (CO5):

1. Explains Stephan Boltzmann law of heat radiation?
2. Explain Wien's displacement law?

MODEL QUESTION PAPER
APJ ABDUL KALAM TECHNOLOGICAL UNIVERSITY
SIXTH SEMESTER MECHANICAL ENGINEERING
Heat Transfer-MET384

Maximum: 100 Marks

Duration: 3 hours

PART A

Answer all questions. Each question carries 3 marks

1. Explain Fourier's law of heat conduction?
2. What are the factors affecting thermal conductivity of solids, liquids and gases?
3. Write the equation for one dimensional heat conduction through a plane wall and represent it in a form of electrical analogy?
4. What is critical thickness of insulation and what is its importance?
5. Define Reynolds Number, Prandtl Number and Nusselt Number?
6. What is the difference between free and forced convection?
7. What is meant by NTU in heat exchangers? When it is used?
8. What is effectiveness of a heat exchanger?
9. Explains Stephan Boltzmann law of heat radiation?
10. Explain Wien's displacement law?

(10 X 3 = 30 Marks)

PART B

Answer one full question from each module

MODULE 1

11. a) Derive general conduction equation in Cartesian coordinate? (10 marks)
- b) reduce the equation for steady one dimensional conduction heat transfer for homogeneous isotropic material without heat generation. (4marks)

12. a) Explain three different modes of heat transfer? (10 marks)

- b) Write down the general conduction equation in cylindrical coordinate and explain the terms?

(4 marks)

MODULE II

13. a) The interior temperature of a refrigerator is maintained at 7°C . The walls are constructed with two mild steel sheets 3 mm thick with 5 cm of glass wool insulation between them. The heat transfer coefficients on inner and outer surface of refrigerator are $10 \text{ W/m}^2\text{C}$ and $12.5 \text{ W/m}^2 \text{ C}$ respectively. Find the rate of heat leaked the refrigerator in watts when it is kept in a kitchen room. Also find inter wall temperatures. The temperature in kitchen room is 28°C . Take K (mild steel) $=40 \text{ W/m}^{\circ}\text{C K}$ (glass wool) $=0.04 \text{ W/m}^{\circ}\text{C}$. (10 marks)

- b) Write an expression for one dimensional heat transfer along radial direction, through a hollow cylindrical surface of radius R_1 and R_2 , thermal conductivity K and length L . express it as an analogy of electric flow (4 marks)

- 14 a) Derive an expression for heat flow through “rectangular fin” of infinite length ? (12 marks)

- b) What is the propose of a fins? (2 marks)

MODULE III

- 15 a) Air at 20°C at atmospheric pressure flows over a flat plate at a velocity of 3 m/s. If the plate is 1 m wide and at 80°C , calculate the following at $x = 300 \text{ mm}$. Determine Hydrodynamic boundary layer thickness, Thermal boundary layer thickness, Local friction coefficient, Average heat transfer coefficient, Heat transfer rate (10 marks)

- b) What is the difference between laminar and turbulent flow? (4 marks)

- 16 a) Air at pressure of 1 atm and temperature 60°C flows over a flat plate which maintains a surface temperature of 100°C . The plate has a length of 0.2m (in the flow direction) and width of 0.1m. The Reynolds number based on the plate length is 40000. What is the rate of heat transfer from plate to air? If the free stream velocity of air is doubled and the pressure is increased to 2.5 atm, what is the rate of heat transfer? (12 marks)

- b) What is the importance of Reynolds number? (2 marks)

MODULE IV

17. a) Derive an expression for LMTD of “parallel flow” heat exchanger (10 marks)

- b) What is fouling and scaling of heat exchangers? How to accommodate this factor in calculation

(4 marks)

18. a) A chemical having specific heat of 3.3 KJ/kg K, flowing at the rate of 20000 kg/h enters a parallel flow heat exchanger at 120° C. The flow rate of cooling water is 50000 kg/h with an inlet temperature of 20°C. The heat transfer area is 10 m² and the overall heat transfer coefficient is 1050 W/m² K. Take specific heat of water as 4.186 KJ/kg K. Find: (i) The effectiveness of the heat exchanger. (ii) The outlet temperature of water and chemical.

(12 marks)

b) Explain matrix type of heat exchangers?

(2 marks)

MODULE V

19 a) Calculate the heat exchange by radiation between the surfaces of two long cylinders having radii 120 mm and 60 mm respectively. The axes of the cylinders are parallel to each other. The inner cylinder is maintained at a temperature of 130°C and emissivity of 0.6. Outer cylinder is maintained at a temperature of 30°C and emissivity of 0.5.

(10 marks)

b) Explains Stephan Boltzmann law of heat radiation?

(4 marks)

20. a) Calculate the radiation exchange per unit area between two parallel plates of temperature 4000C and 250C. Emissivity of hot and cold plates are 0.9 and 0.7 respectively. Find the percentage reduction in heat transfer, if a radiation shield of emissivity 0.25 is placed in between the plates

(7 marks)

b) Explain Wien's displacement law?

(7 marks)

Syllabus

Module 1- INTRODUCTION TO HEAT TRANSFER

Modes of Heat Transfer: Introduction to Conduction, Convection, radiation. Conduction: Fourier law of heat conduction-Thermal conductivity of solids, liquids and gases-Factors affecting thermal conductivity- Most general heat conduction equation in Cartesian and cylindrical coordinates.

Module 2 CONDUCTION HEAT TRANSFER

One dimensional steady state conduction with and without heat generation conduction through plane walls, cylinders. Critical thickness of insulation – Heat transfer through composite wall- extended surface heat transfer – fin performance – effect of variable thermal conductivity.

Module 3 CONVECTION HEAT TRANSFER

Convection heat transfer: Newton's law of cooling- Free and forced convection. Laminar and Turbulent flow, Reynolds Number, Critical Reynolds Number, Prandtl Number, Nusselt Number, Grashoff Number and Rayleigh's Number. Elementary ideas of hydrodynamics and thermal boundary layers-Thickness of Boundary layer-Displacement, Momentum and Energy thickness (description only).

Module 4 HEAT EXCHANGERS

Heat exchangers: Classification – log mean temperature difference – overall heat transfer coefficient – fouling and scaling of heat exchangers – LMTD and NTU method of performance evaluation of heat exchangers.

Module 5 RADIATION HEAT TRANSFER

Radiation: Fundamentals of radiation – radiation spectrum – thermal radiation – concept of black body and grey body – monochromatic and total emissive power – absorptivity, reflectivity and transmissivity - laws of radiation – radiation between two surfaces – geometrical factors for simple configuration – radiation shields – electrical network method of solving problems.

Text Books

1. Sachdeva R. C., Fundamentals of Engineering Heat and Mass Transfer, New Age Science Limited
2. R. K. Rajput, Heat and mass transfer, S. Chand & Co.
3. Nag P. K., Heat and Mass Transfer, McGraw Hill.
4. Kothandaraman, C.P., Fundamentals of Heat and Mass Transfer, New Age International, New Delhi.

Data Book

Heat and Mass Transfer data book: C.P. Kothandaraman, S. Subramanyan, New age International publishers.

Reference Books

1. Holman J.P, “Heat transfer”, Mc Graw-Hill, 10th. Ed.
2. Yunus A Cengel, “Heat and Mass Transfer: Fundamentals and Applications” McGraw-Hill Higher Education.
3. Frank P. Incropera and David P. Dewitt, Heat and Mass Transfer, John Wiley and sons.

COURSE PLAN

MODULE	TOPICS	HOURS ALLOTTED
1	Modes of Heat Transfer: Introduction to Conduction, Convection, radiation. Conduction: Fourier law of heat conduction-Thermal conductivity of solids, liquids and gases-Factors affecting thermal conductivity	4-0-0
	General heat conduction equation in Cartesian coordinates. General heat conduction equation in Cylindrical coordinates	3-1-0
2	One dimensional steady state conduction with and without heat generation conduction through plane walls, cylinders. Critical thickness of insulation – Heat transfer through composite wall- extended surface heat transfer – fin performance – effect of variable thermal conductivity.	8-2-0
	Convection heat transfer: Newton’s law of cooling- Free and forced convection. Laminar and Turbulent flow, Reynolds Number, Critical	

3	Reynolds Number, Prandtl Number, Nusselt Number, Grashoff Number and Rayleigh's Number. Elementary ideas of hydrodynamics and thermal boundary layers-Thickness of Boundary layer-Displacement, Momentum and Energy thickness	7-2-0
4	Heat exchangers: Classification – log mean temperature difference – overall heat transfer coefficient – fouling and scaling of heat exchangers – LMTD and NTU method of performance evaluation of heat exchangers	8-2-0
5	Radiation: Fundamentals of radiation – radiation spectrum – thermal radiation – concept of black body and grey body – monochromatic and total emissive power – absorptivity, reflectivity and transmissivity - laws of radiation – radiation between two surfaces – geometrical factors for simple configuration – radiation shields – electrical network method of solving problems.	7-2-0

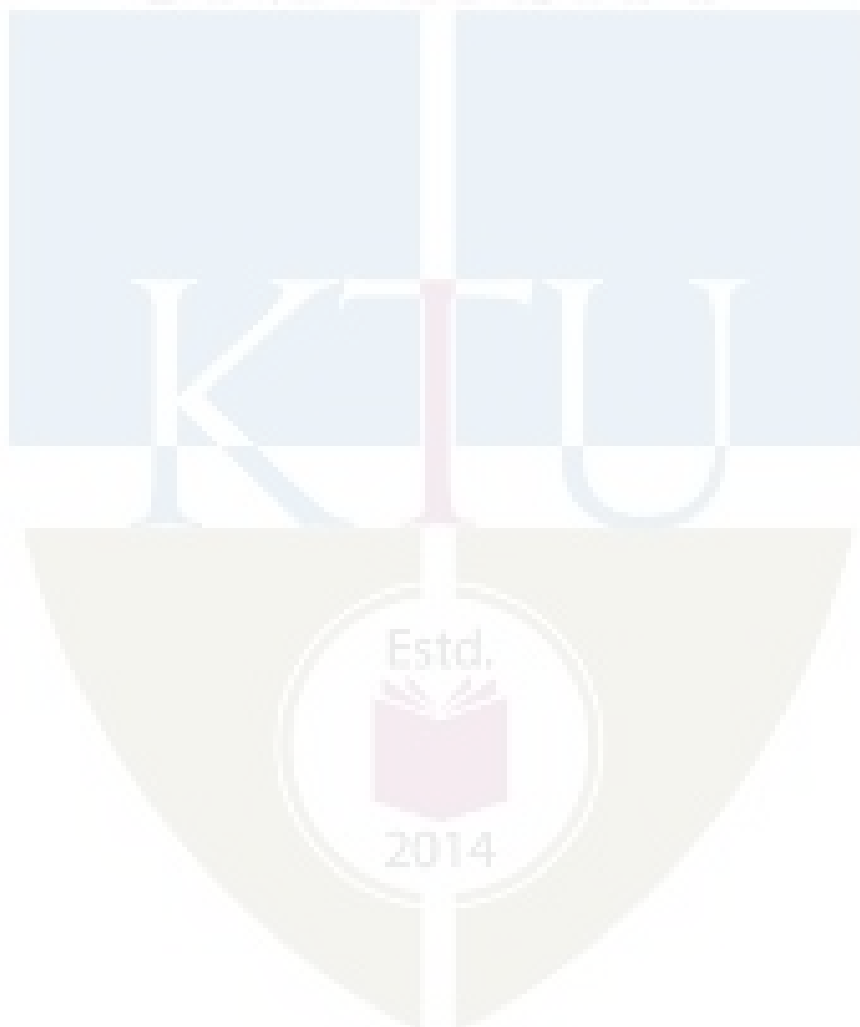

MET386	INDUSTRIAL ENGINEERING	CATEGORY	L	T	P	CREDIT
		VAC	3	1	0	4

Preamble: This course helps an engineering student to understand the functions and techniques of Industrial Engineering. It addresses economic aspects of the business decision and the concepts of human factors in design. The course involves productivity improvement methods, Work study, Method study and Time study. Industrial Engineering Tools and Techniques for Plant management including Plant layout and Material handling are also covered in this course. The students also will able understand Production Planning and Control process, and procedures. The other focus areas of Industrial Engineering, Quality practices, Project Management and Replacement technique are also part of this course.

Prerequisite: NIL

Course Outcomes: After the completion of the course the student will be able to

CO 1	Understand the functions of Industrial Engineering, Economic aspects of business and Human factors in design
CO 2	Apply Principles of Work study, Method study and Work measurement techniques.
CO 3	Develop layout for a manufacturing/service system and apply plant management and Material handling techniques.
CO 4	Evaluate Production Planning and Control techniques and Inventory control
CO 5	Analyse Quality practices, and Apply Project Management and Replacement techniques.

Mapping of course outcomes with program outcomes

	PO 1	PO 2	PO 3	PO 4	PO 5	PO 6	PO 7	PO 8	PO 9	PO 10	PO 11	PO 12
CO 1			2			3	3				3	
CO 2		3	3			3						
CO 3		3	3		3							
CO 4		3	3	3	3						3	
CO 5		3	3	3		3	3				3	

Assessment Pattern

Bloom's Category	Continuous Assessment Tests		End Semester Examination
	1	2	
Remember	10	10	10
Understand	20	20	20
Apply	20	20	70
Analyse			
Evaluate			
Create			

Mark distribution

Total Marks	CIE	ESE	ESE Duration
150	50	100	3 hours

Continuous Internal Evaluation Pattern:

Attendance : 10 marks

Continuous Assessment Test (2 numbers) : 25 marks

Assignment/Quiz/Course project : 15 marks

End Semester Examination Pattern: There will be two parts; Part A and Part B. Part A contain 10 questions with 2 questions from each module, having 3 marks for each question. Students should answer all questions. Part B contains 2 questions from each module of which student should answer any one. Each question can have maximum 2 sub-divisions and carry 14 marks.

Course Level Assessment Questions**Course Outcome 1 (CO1):**

1. State functions of an Industrial Engineer which will lead to improvement in productivity?.
2. How the productivity of s system can be improved? List factors affecting productivity that can be controlled.

3. Asian industries specialize in the manufacture of small capacity motors. The cost structure of the motor is as under

Material	Rs 50/-
Labour	Rs 80/-
Variable overhead	75% of labour cost
Fixed cost of the company amount 2,40,000 Rs/annum	
The sales price of the motor is Rs 230/- each	

Determine the number of motors to be manufactured to break even

How many motors are to be sold to make a profit of Rs 1 Lakh

If the sale price is reduced by Rs. 15/- how many motors are to sold to break even

Course Outcome 2 (CO2)

1. What is the concept of work content? What are reasons for excess of work content?
2. Differentiate between Two hand process chart and Multiple Activity chart.
3. The following data refers to the study conducted for an operation. The table shows the actual time for elements in minutes.

Cycle elements	1	2	3	4	5
1	2.5	2.6	2.4	2.5	2.5
2	6.0	6.2	6.1	5.9	6.0
3	2.3	2.1	2.4	2.2	2.3
4	2.4	2.5	2.6	2.8	2.5

i) Element 3 is machine elements

ii) Take performance rating as 110

Take following personal allowance of 30 minutes in shift of 8 hours, fatigue allowance 15%, contingency allowance 2%. Estimate the standard time for the operation and production per 8 hour shift.

Course Outcome 3(CO3):

1. List the different types of layout. Differentiate between Product and process layout based any five parameters.
2. Consider the following assembly network relationships of a product. The number of shifts per day is two and the number of working hours per shift is 8. The company aims to produce 80 units of the product per day. Group the activities into work stations using Ranking Positional Weight method and compute balancing efficiency.

Operation Number	Immediate predecessor	Duration (Min)
1	-	7
2	1	2
3	1	2
4	1	5
5	2,3	8
6	3,4	3
7	5	4
8	5,6	7
9	4,6	9
10	7,8,9	8

3. The initial cost of an equipment is Rs 21000/- expected salvage value Rs 1000 and expected useful life of 10 years. Calculate the depreciation and book value after 1 year and 9 years using sinking fund method and straight line method. Take interest rate as 6%

Course Outcome 4 (CO4):

1. Explain the steps of Production planning Process,
2. Describe the importance Product Life cycle in Product development and Management
3. A manufacturer has to supply his customer a 2400 units of his products per year. Shortages are not permitted. Inventory carrying cost amounts to Rs. 0.8/- per unit per annum. The setup cost per run is Rs 60/- . Find
 - i. EOQ
 - ii. Optimum number of order per annum

- iii. Average annual inventory cost(min)
- iv. Optimum period of supply per order

Course Outcome 5 (CO5):

1. Explain the Procedure of X and R chart .
2. The mortality rate are given in the table below for certain type of electric bulb. There are 2000 bulb in use and it costs Rs 12/- to replace an individual bulb that has burnt. If all the bulbs are replaced simultaneously, it would cost Rs. 4/- per bulb. It is proposed to replace all the bulbs in fixed intervals, whether or not they have burnt out and to continue replacing burnt bulbs out bulbs if they fail. At what intervals should all the bulbs be replaced?

Week	1	2	3	4	5	6
Probability of failure	0.05	0.2	0.25	0.3	0.15	0.05

Model Question paper

**APJ ABDUL KALAM TECHNOLOGICAL UNIVERSITY
SIXTH SEMESTER B.TECH DEGREE EXAMINATION**

Course Code : MET386

Course Name : **INDUSTRIAL ENGINEERING**

Max. Marks : 100

Duration : 3 Hours

Part A

(ANSWER ALL QUESTIONS, EACH QUESTION CARRIES 3 MARKS)

1. What are the factors influencing productivity?
2. Explain the role ergonomics plays in environmental man-machine interface
3. What is micro motion study? What are the steps involved?
4. Explain flow diagram with example
5. Explain REL Chart
6. Explain the criteria for selecting Material handling equipment
7. How order promising is done during Production planning
8. Briefly explain any three selective inventory control techniques

9. Explain the significance of Bathtub curve
10. Briefly explain the stages of TQM implementation

Part B

(ANSWER ONE FULL QUESTION FROM EACH MODULE)

Module 1

11. a) Explain the factors affecting make or buy decisions. (7marks)
- b) ABC company plans to sell an article at local market. The articles are purchased at Rs 5 on the condition that all unsold items shall be returned. The rent for the space Rs 2000. The article will be sold at Rs 9 . Determine the number of articles which must be sold to i) to break even ii) to earn Rs 400 profit iii)if the company sells 750 articles . Calculate the margin of Safety (7 marks)
12. a) Explain the principles in the application of Anthropometric data. How it can be used in work place design? (8 marks)
- b) Explain the functions of Industrial Engineering (6 Marks)

Module 2

13. a) Explain the use recording techniques in method study. Differentiate between Operations Process chart and Flow process chart. (7 Marks)
- b) The observed time and the performance rating for five elements are given. Compute the standard time assuming rest and personal allowance as 15% and contingency as 2% of basic time.

Element	1	2	3	4	5
Observed time	0.2	0.08	0.50	0.12	0.10
Performance rating	85	80	90	85	80

(7 Marks)

- 14 a) Explain the different techniques used for work measurement. (7 Marks)

b) The following data refers to the study conducted for an operation. The table shows the actual time for elements in minutes.

Cycle elements	1	2	3	4	5
1	2.5	2.6	2.4	2.5	2.5
2	6.0	6.2	6.1	5.9	6.0
3	2.3	2.1	2.4	2.2	2.3
4	2.4	2.5	2.6	2.8	2.5

i) Element 3 is machine elements

ii) Take performance rating as 110

Take following personal allowance of 30 minutes in shift of 8 hours, fatigue allowance 15%, contingency allowance 2%. Estimate the standard time for the operation and production per 8 hour shift. (7 Marks)

Module 3

15. a) Explain Systematic Layout planning with the help of block diagram. (6 Marks)

b) Consider the following assembly network relationship of a product. The number of shifts per day is two and the number of working hours per shift is 12. The company aims to produce 100 units of the product per day. Group the activities into work stations using Rank Positional Weight Method and compute balancing efficiency.

Operation number	Immediate preceding Tasks	Duration (Min)
1	-	7
2	1	2
3	1	2
4	1	5
5	2,3	8
6	3,4	3

7	5	4
8	5,6	7
9	4,6	9
10	7,8,9	8

(8 Marks)

16 a) The initial cost of an equipment is Rs 21000/- expected salvage value Rs 1000 and expected useful life of 10 years. Calculate the depreciation and book value after 1 year and 9 years using sinking fund method and straight line method. Take interest rate as 6%. (6 Marks)

b) The price of an office equipment is Rs 2.5 lakhs the salvage value at the end of 10 years is Rs 25,000/ Calculate the amortised value after 5 years by using i) sinking fund method ii) declining balance method. (8 Marks)

Module 4

17 a) What are the different types of Production system, explain (7 Marks)

b) Consider the following 3 machine and 5 jobs flow shop problem. Check whether Johnson's can be extended to this problem. What is the optimal schedule for this problem and corresponding makespan? Draw the Gantt chart.

Job	Machine 1	Machine 2	Machine 3
1	11	10	12
2	13	8	20
3	15	6	15
4	12	7	19
5	20	9	7

(7 Marks)

18 a) Explain the Product Life cycle and its importance in Product management. (7 Marks)

b) ABC industry needs 15,000 units/year of a bought out component which will be used in its main product. The ordering cost is Rs. 125 per order and holding cost per unit per year is 20% of the purchase price per unit which is Rs. 75.

- i. Find economic order quantity
- ii. Number of order per year
- iii. Time between successive orders

The activities involved in ABC manufacturing company are listed below with their time estimates. Draw the network for the given activities and carry out critical path calculations.

(7 Marks)

Module 5

19 a) Differentiate between PERT and CPM, Specify the difference in application (6 Marks)

b) Consider the following data of the project

Activity	Predecessor	Duration (Weeks)		
		<u>a</u>	<u>m</u>	<u>b</u>
A	—	3	5	8
B	—	6	7	9
C	A	4	5	9
D	B	3	5	8
E	A	4	6	9
F	C,D	5	8	11
G	C,D,E	3	6	9
H	F	1	2	9

- i. Construct the project network
- ii. Find expected duration and variance of each activity
- iii. What is the probability of completing the project in 30 weeks?

(8 Marks)

20 a) What is Process Capability? Explain the significance Process capability Index

(7 Marks)

b)The cost of a machine is Rs. 60,000/-. The salvage value and the running costs of a machine are shown in the table. Depreciation is cumulative. Find the most economical replacement age of the machine. (7 marks)

Year	1	2	3	4	5	6
Running cost in Rs.	12050	14100	16375	18875	20500	24550
Resale value in Rs	40000	30000	25000	15000	10500	7000

Syllabus

Module 1

Introduction to Industrial Engineering - Evolution of modern Concepts in Industrial Engineering - Functions of Industrial Engineering.
 Productivity- productivity measures- dynamics of productivity change- Techniques for improving productivity.
 Production costs concepts – Manufacturing Vs Purchase- problems- Economic aspects- C-V-P analysis – simple problems..
 Ergonomics Man-Machine systems-Anthropometry Work place design and ergonomics - Value Engineering.

Module 2

Work study-procedure-concept of work content- techniques to reduce work content.
 Method Study-steps-recording techniques-operation process chart-flow process chart-two hand process chart-multiple activity chart. Diagrams- Flow diagrams-String diagrams. Micro-motion study-SIMO chart- critical examination. Principle of motion economy.
 Work measurement- techniques of work measurement - Time Study- - Steps in time study-calculation of standard time (problems)- allowances.

Module 3

Plant location, plant layout and material handling- Type of layouts and characteristics –Tools and techniques for plant layout- travel chart – REL chart- Computer algorithms for layout design CRAFT-ALDEP (methods only)- Systematic layout planning -Line balancing–RPW (problem).
 Principles of material handling-selection and type of material handling equipment- Unit load concept- Automated Material Handling Systems- AGVs.
 Depreciation -Method of providing for depreciation- straight line method- Declining balance method- Sinking fund methods (Problems)

Module 4

Production Planning and control -Types of Production systems.
 Demand forecasting- Forecasting methods, Aggregate planning- methods- Master Production Schedule-techniques-order promising- Material Requirement Planning-bill of material-

product structure diagram- MRP record processing- Shop floor control - Scheduling flow shop and job shop scheduling methods, Johnson's algorithm-dispatching rules - Gantt charts. Introduction and need for a new product-product life cycle.
Inventory Control, Inventory models – Basic model -price discounts -problems – determination of safety stock - Selective inventory control techniques

Module 5

Quality control - Statistical quality control –causes of variation in quality- control charts for X and R (problems). Process Capability- process capability index- Reliability-causes of failures- Bath tub curve.-System reliability. Introduction to concepts of, TQM, ISO, Six Sigma and Quality circles.

Project management- Critical Path Method, PERT, crashing of networks

Determination of economic life -Replacement policy-- Methods of replacement analysis.

Text Books

1. Martand Telsang, Industrial Engineering & Production Management, S. Chand, Third revised edition 2018.
2. B. Kumar, Industrial Engineering Khanna Publishers, Tenth Edition 2015
3. Thomas E Vollmann , William L Berry , D Clay Whybark, F Robert Jacobs, Manufacturing Planning and Control for Supply Chain Management, McGraw Hill Education (India) Private Limited, Fifth Edition 2017
4. M Mahajan, Industrial Engineering & Production Management, Dhanpat Rai, 2015
5. O. P. Khanna, Industrial Engineering and Management, Dhanpat Rai, 2018

Reference Books

1. E. S. Buffa, Modern Production management, John Wiley, 1983
2. Grant and Ieven Worth, Statistical Quality Control, McGraw Hill, 2000
3. Ralph M Barnes, Motion and Time Study, Wiley, 1980
4. Richard L. Francis, F. McGinnis Jr., John A. White, Facility Layout and Location: An Analytical Approach, 2nd Edition, 1991

Course Contents and Lecture Schedule

No	Topic	No. of Lectures
1	<p>Introduction to Industrial Engineering - Evolution of modern Concepts in Industrial Engineering - Functions of Industrial Engineering.</p> <p>Productivity- productivity measures- dynamics of productivity change- Techniques for improving productivity.</p> <p>Production costs concepts – Manufacturing Vs Purchase- problems- Economic aspects- C-V-P analysis – simple problems..</p> <p>Ergonomics Man-Machine systems-Anthropometry Work place design and ergonomics - Value Engineering</p>	7-2-0
2	<p>Work study-procedure-concept of work content- techniques to reduce work content.</p> <p>Method Study-steps-recording techniques-operation process chart-flow process chart-two hand process chart-multiple activity chart. Diagrams- Flow diagrams-String diagrams.</p> <p>Micro-motion study-SIMO chart- critical examination. Principle of motion economy.</p> <p>Work measurement- techniques of work measurement - Time Study- - Steps in time study- calculation of standard time (problems)- allowances</p>	7-2-0
3	<p>Plant location, plant layout and material handling- Type of layouts and characteristics – Tools and techniques for plant layout- travel chart – REL chart- Computer algorithms for layout design CRAFT-ALDEP (methods only)- Systematic layout planning -Line balancing–RPW (problem).</p> <p>Principles of material handling-selection and type of material handling equipment- Unit load concept- Automated Material Handling Systems- AGVs.</p> <p>Depreciation -Method of providing for depreciation- straight line method- Declining balance method- Sinking fund methods (Problems)</p>	7-2-0
4	<p>Production Planning and control -Types of Production systems.</p> <p>Demand forecasting- Forecasting methods, Aggregate planning- methods- Master Production Schedule-techniques-order promising- Material Requirement Planning-bill of material-product structure diagram- MRP record processing- Shop floor control - Scheduling flow shop and job shop scheduling methods, Johnson’s algorithm-dispatching rules -- Gantt charts.</p> <p>Introduction and need for a new product-product life cycle.</p> <p>Inventory Control, Inventory models – Basic model -price discounts -problems – determination of safety stock - Selective inventory control techniques</p>	7-2-0
5	<p>Quality control - Statistical quality control –causes of variation in quality- control charts for X and R (problems). Process Capability- process capability index- Reliability-causes of failures- Bath tub curve.-System reliability. Introduction to concepts of, TQM, ISO, Six Sigma and Quality circles.</p> <p>Project management- Critical Path Method, PERT, crashing of networks</p> <p>Determination of economic life -Replacement policy-- Methods of replacement analysis.</p>	7-2-0

APJ ABDUL KALAM
TECHNOLOGICAL
UNIVERSITY

SEMESTER VI

HONOURS



CODE MET394	COURSE NAME ADVANCED DESIGN SYNTHESIS	CATEGORY	L	T	P	CREDIT
		VAC	3	1	0	4

Preamble:

- To give an overview of the techniques used in Mechanical Engineering for the analysis and synthesis of Mechanisms.
- To familiarize the graphical and analytical techniques commonly used in the synthesis of mechanisms.
- To provide sufficient theoretical background to understand contemporary mechanism design techniques.
- To develop skills for applying these theories in practice. Identify mechanisms by type of motion (Planar, Spatial etc.)
- Select the best type of mechanism for a specific application and apply the fundamental synthesis technique to properly dimension the mechanism

Course Outcomes: After the completion of the course the student will be able to

CO 1	Analyse Velocity and Acceleration Analysis of complex mechanisms using auxiliary points
CO 2	Solve the synthesis of slider crank mechanism with three accuracy points
CO 3	Explain the synthesis of slider crank mechanism with four accuracy points
CO 4	Describe the algebraic methods of synthesis using displacement equations
CO 5	Demonstrate the algebraic methods of synthesis using complex numbers

Mapping of course outcomes with program outcomes

	PO 1	PO 2	PO 3	PO 4	PO 5	PO 6	PO 7	PO 8	PO 9	PO 10	PO 11	PO 12
CO 1	3	3	2									
CO 2	3	3	2									
CO 3	3	3	2									
CO 4	3	3	2									
CO 5	3	3	2									

Assessment Pattern

Bloom's Category	Continuous Assessment Tests		End Semester Examination
	1	2	
Remember	10	10	10
Understand	20	20	20
Apply	20	20	70
Analyse			
Evaluate			
Create			

Mark distribution

Total Marks	CIE	ESE	ESE Duration
150	50	100	3 hours

Continuous Internal Evaluation Pattern:

Attendance	: 10 marks
Continuous Assessment Test (2 numbers)	: 25 marks
Assignment/Quiz/Course project	: 15 marks

End Semester Examination Pattern: There will be two parts; Part A and Part B. Part A contain 10 questions with 2 questions from each module, having 3 marks for each question. Students should answer all questions. Part B contains 2 questions from each module of which student should answer any one. Each question can have maximum 2 sub-divisions and carry 14 marks.

Course Level Assessment Questions**Course Outcome 1 (CO1):**

1. Calculate Velocity and Acceleration Analysis of complex mechanisms using auxiliary points.
2. Describe Roberts – Chebyshev theorem.
3. Explain the Inflection circle, Euler- Savery equation, and Hartman construction.

Course Outcome 2 (CO2)

1. Describe about the Relative poles of four bar linkages and slider crank mechanism.
2. List out the usage of Function generators.
3. Execute the synthesis of slider crank mechanism with three accuracy points.

Course Outcome 3(CO3):

1. Execute the geometric methods of synthesis with four accuracy points.
2. Discuss about the Construction of circle points, Cardinal points, opposite poles, and Pole quadrilaterals
3. Do the synthesis of slider crank mechanism with four accuracy points.

Course Outcome 4 (CO4):

1. Demonstrate the algebraic methods of synthesis using displacement equations.
2. Execute the Crank and follower synthesis.
3. Describe the method to get angular velocities and accelerations from crank and follower synthesis.

Course Outcome 5 (CO5):

1. Discuss about the Algebraic methods of synthesis using complex numbers.
2. Explain the importance Spatial motion and spatial linkages.
3. Demonstrate working of the Simple mechanisms in Robots.

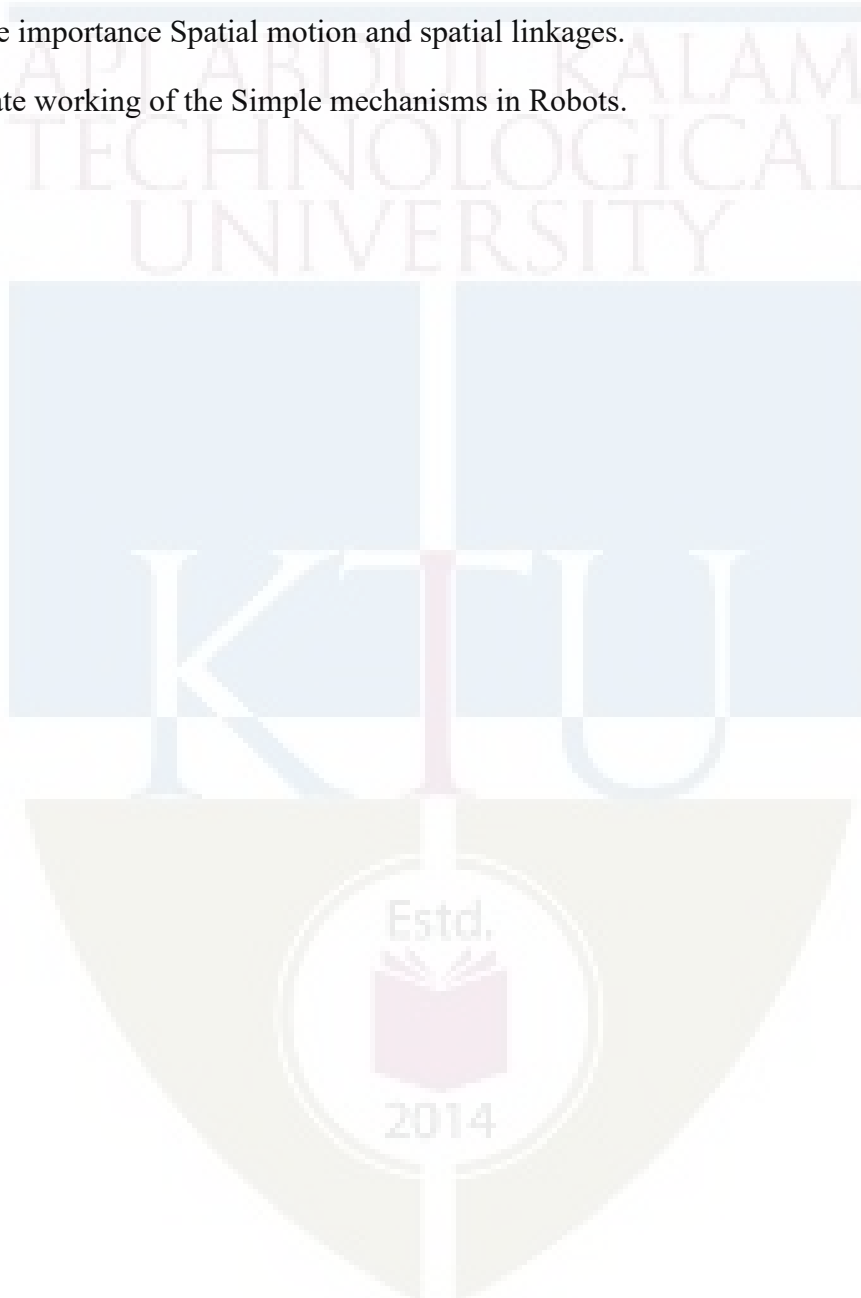

MODEL QUESTION PAPER

APJ ABDUL KALAM TECHNOLOGICAL UNIVERSITY
SIXTH SEMESTER B. TECH DEGREE EXAMINATION
Course Code: MET394

Course Name: **ADVANCED DESIGN SYNTHESIS**
Max. Marks: **100**
Duration: **3 Hours**

PART – A

(ANSWER ALL QUESTIONS, EACH QUESTION CARRIES 3 MARKS)

1. State and explain Robert Chebychev theorem?
2. Explain the properties of inflection circle?
3. What are three accuracy points in cam and follower synthesis?
4. Explain the relative poles of slider crank mechanism with sketch?
5. What is the significance function generator in the design of a mechanism?
6. Explain pole quadrilateral in geometric synthesis?
7. Define center point and circle point?
8. Write notes on types of errors in synthesis?
9. Draw a simple robot mechanism?
10. Classify the various types of spatial mechanisms?

PART – B

(ANSWER ONE FULL QUESTION FROM EACH MODULE)

MODULE – 1

11. For the twin cylinder V engine, determine the velocity of pistons B and D and the angular velocity of link 3. Link 2 rotates at 2000rpm. The dimensions of the various links are: $O_2A = 50\text{mm}$; $AB = BC = 150\text{mm}$; $AC = 50\text{mm}$; $CD = 125\text{mm}$

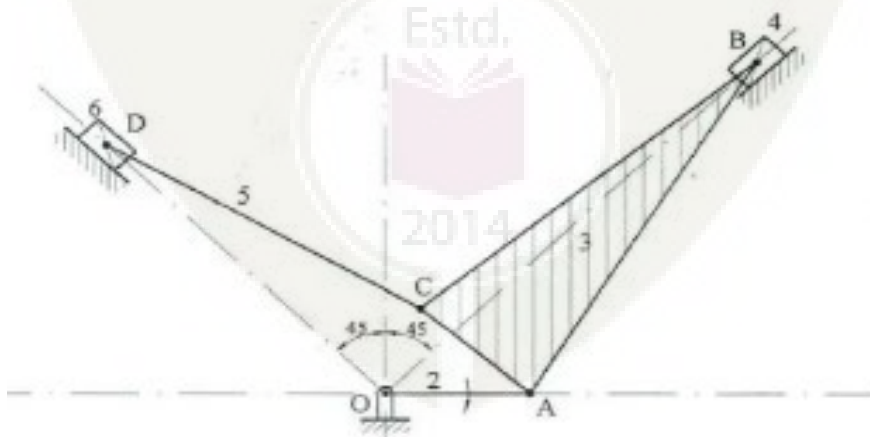

(14 marks)

12. Using overlay method and Chebychev spacing design a four-bar mechanism to generate the function $y = x^{1.5}$ for $0.5 < x < 1.5$. Assume six precision points. (14 marks)

Module 2**MECHANICAL ENGINEERING**

13. a) Discuss the significance of transmission angle in the design of a four-bar mechanism. (6 marks)

b) Explain the procedure for design of a four-bar mechanism for optimum transmission angle. (8 marks)

14. Design a function generator linkage to solve $y = 1/x$ in the range $1 < x < 2$ using three precision points using geometric method. $\Delta\Phi = 90^\circ$, $\Delta\Psi = 90^\circ$, $\Phi_0 = 90^\circ$, $\Psi_0 = 45^\circ$. Plot a curve of the desire function and the one generated by the synthesized linkage and find the maximum error percentage. (14marks)

Module 3

15. Design a slider crank mechanism such that $\Phi_{12} = 30^\circ$ and $\Phi_{23} = 50^\circ$ and $S_{12} = 25$ cm and $S_{23} = 20$ cm using geometric method. The input crank moves in clockwise direction and the slider moves away from the crank pivot. (14 marks)

16. Design a double rocker mechanism to generate the function $y = e^x$ in the range $1 \leq x \leq 1$ using four precision points and Chebychev spacing using geometric method. (14 marks)

Module 4

17. Synthesize a four-bar generator to generate the function $y = \log_{10} x$ in the range $1 \leq x \leq 2$ using algebraic method. Assume suitable starting angles and ending angles for motion of input and output links. Use three precision points and Chebychev spacing. Find out the maximum error. (14marks)

18. Synthesize a four-bar linkage to meet the following specification of position, velocity and acceleration

$\Phi = 60^\circ$	$\Psi = 90^\circ$	(14 marks)
$\omega_\Phi = 5$ rad/s	$\omega_\Psi = 2$ rad/s	
$\alpha_\Phi = 2$ rad/s ²	$\alpha_\Psi = 7$ rad/s ²	

Module 5

19. Synthesize a four-bar linkage to satisfy the following specifications:

$\omega_2 = 200$ rad/s,	$\omega_3 = 85$ rad/s,	$\omega_4 = 130$ rad/s	(14 marks)
$\alpha_2 = 0$ rad/s ² ,	$\alpha_3 = -1000$ rad/s ² ,	$\alpha_4 = -1600$ rad/s ²	

20. Compute the link lengths of a four-bar mechanism that will in one of its positions satisfy the following specifications: $\omega_1 = 8$ rad/sec, $\alpha_1 = 0$, $\omega_2 = 1$ rad/sec, $\alpha_2 = 20$ rad/sec², $\omega_3 = -3$ rad/sec, $\alpha_3 = 0$. (14 marks)

Syllabus

MECHANICAL ENGINEERING

Module 1

Floating Link, Special methods of velocity and acceleration analysis using auxiliary points. Overlay method for conditioned crank mechanisms, coupler curves.

Roberts – Chebyshev theorem. Inflection circle, Euler- Savary equation, Hartman construction, Bobillier construction.

Module 2

Synthesis using Optimum transmission angle.

Geometric methods of synthesis with three accuracy points: - poles of four bar linkages, Relative poles of four bar linkages, Function generators, poles of slider crank mechanisms, Relative poles of slider crank Mechanisms, Rectilinear recorder mechanisms.

Synthesis of slider crank mechanism with three accuracy points.

Module 3

Geometric methods of synthesis with four accuracy points: - pole triangles, center point curves, Circle point curves, Construction of circle points, Cardinal points, opposite poles, Pole quadrilaterals,

Function Generators, Synthesis of slider crank mechanism with four accuracy points.

Module 4

Algebraic methods of synthesis using displacement equations: - Crank and follower synthesis- three accuracy points.

Crank and follower synthesis- angular velocities and accelerations.

Module 5

Rectilinear mechanisms, Algebraic methods of synthesis using complex numbers. Spatial motion and spatial linkages. Types of spatial mechanisms, Single loop linkage and multiple loop linkages. Simple mechanisms in robots.

Text Books

1. Kinematic synthesis of Linkages by Richard.S.Hartenberg, Jacques Denavit, McGraw Hill book company. 1964
2. Kinematics and linkage design by Allen.S.Hall. Prentice Hall of India, Ltd. 1986
3. Theory of Mechanisms and Machines by Shigley, McGraw Hill International Edition., 4th edition, 2014
4. Dynamics of Machinery by A.R.Holowenko. John Wiley & Sons Inc, 1955

Course Contents and Lecture Schedule

No	Topic	No. of Lectures
1	Module 1	
1.1	Floating Link, Special methods of Velocity and Acceleration Analysis using auxiliary points.	3
1.2	Overlay method for conditioned crank mechanisms, coupler curves. Roberts – Chebyshev theorem	3
1.3	Inflection circle, Euler- Savary equation, Hartman construction, Bobillier construction. Synthesis using Optimum transmission angle	3
2	Module 2	
2.1	Geometric methods of synthesis with three accuracy points: - poles of four bar linkages, Relative poles of four bar linkages,	3
2.2	Function generators, poles of slider crank mechanisms, Relative poles of slider crank Mechanisms, Rectilinear recorder mechanisms.	3
2.3	Synthesis of slider crank mechanism with three accuracy points.	3
3	Module 3	
3.1	Geometric methods of synthesis with four accuracy points: - pole triangles, center point curves,	3
3.2	Circle point curves, Construction of circle points, Cardinal points, opposite poles, Pole quadrilaterals,	3
3.3	Function Generators, Synthesis of slider crank mechanism with four accuracy points.	3
4	Module 4	
4.1	Algebraic methods of synthesis using displacement equations: - Crank and follower synthesis- three accuracy points	4
4.2	Crank and follower synthesis- angular velocities and accelerations	4
5	Module 5	
5.1	Rectilinear mechanisms, Algebraic methods of synthesis using complex numbers.	3
5.2	Spatial motion and spatial linkages	3
5.3	Types of spatial mechanisms, Single loop linkage and multiple loop linkages. Simple mechanisms in Robots.	3

Assessment Pattern

Bloom's Category	Continuous Assessment			End Semester Examination
	Assignment (%)	Test 1 (%)	Test 2 (%)	
Remember	25	20	20	10
Understand	25	40	40	20
Apply	25	40	40	70
Analyse	25			
Evaluate				
Create				

Mark distribution

Total Marks	CIE	ESE	ESE Duration
150	50	100	3 hours

Continuous Internal Evaluation Pattern:

Attendance	: 10 marks
Continuous Assessment Test (2 numbers)	: 25 marks
Assignment/Quiz/Course project	: 15 marks

End Semester Examination Pattern: There will be two parts; Part A and Part B. Part A contain 10 questions with 2 questions from each module, having 3 marks for each question. Students should answer all questions. Part B contains 2 questions from each module of which student should answer any one. Each question can have maximum 2 sub-divisions and carry 14 marks.

Course Level Assessment Questions

Course Outcome 1 (CO1):

1. Represent various flow regimes on steady flow adiabatic ellipse.
2. List the various conservation laws governing the compressible flow
3. Define Mach cone and Mach Angle

Course Outcome 2 (CO2)

1. Express stagnation enthalpy in terms of static enthalpy and velocity of flow
2. Explain the phenomenon of choking in isentropic flow.
3. Write applications of convergent nozzles and convergent-Divergent nozzles

Course Outcome 3 (CO3):

1. Describe the phenomenon of frictional chocking
2. Differentiate between Fanno flow and Isothermal flow

3. Explain the significance of critical length in Fanno flow

Course Outcome 4 (CO4):

MECHANICAL ENGINEERING

1. Explain the process of thermal choking in Rayleigh flow
2. Under what conditions the assumptions of Rayleigh flow is not valid in a heat exchanger
3. Locate the maximum enthalpy point in Rayleigh flow

Course Outcome 5 (CO5):

1. State and prove Prandtl-Mayer relationship for a normal shock wave.
2. What is an expansion fan? How does it occur in supersonic flow?
3. Explain why shock is impossible in subsonic flow.

Course Outcome 6 (CO6):

1. Name the various types of wind tunnels used for low and high speed testing of models
2. Difference between working principle of Shadowgraph and Schlieren techniques
3. Explain the working principle of constant current hot wire anemometer

MODEL QUESTION PAPER

APJ ABDUL KALAM TECHNOLOGICAL UNIVERSITY

SIXTH SEMESTER MECHANICAL ENGINEERING

Compressible Fluid Flow -MET396

Maximum: 100 Marks

Duration: 3 hours

PART A

Answer all questions. Each question carries 3 marks

1. Derive an expression for stagnation temperature in terms of Mach number for compressible fluid flow.
2. Derive the condition at which flow become choked in isentropic flow?
3. Prove that Mach number is unity at the maximum entropy point on a Fanno curve.
4. Explain the significance of critical length in Fanno flow
5. What is Rayleigh flow? Explain Rayleigh flow with one practical case.
6. Under what conditions the assumptions of Rayleigh flow is not valid in a heat exchanger
7. Explain two situations where a normal shock wave is formed

8. Explain the formation of oblique shock wave in a concave corner and expansion fan in convex corner
9. Mention the difference in principle of the shadowgraph and Schlieren system
10. Explain with the help of sketches how yaw angle is eliminated in a Kiel probe.

(10 X 3 = 30 Marks)

PART B

Answer one full question from each module

MODULE 1

- 11.a. An air nozzle is to be designed for an exit Mach number of 2. conditions of the air available in the reservoir are 700 kPa, 533 K. Estimate i) pressure ii) temperature iii) velocity of flow iv) area, at throat and exit of the nozzle. Mass flow rate through the nozzle is 10000 kg/hr. 10 marks
- b. Derive an expression for area ratio in terms of Mach number for isentropic flow. Explain graphically the variation of area ratio with Mach number. 4 marks
- 12.a. Derive the conservation of mass equation for compressible flow through control volume approach. 4 marks
- b. A perfect gas having $C_p = 1017.4 \text{ J/kg}$ and molecular weight 28.97 flows adiabatically in a converging passage with a mass flow rate of 27.20 kg/s. At a particular location, $M = 0.5$, $T = 500\text{K}$ and $p = 0.25 \text{ MPa}$. Calculate the area of cross section of the duct at the location.

10 marks

MODULE II

- 13.a. A circular duct passes 8.25 kg/s of air at an exit Mach number of 0.5. The entry pressure and temperature are 3.45 bar and 38°C respectively and the mean coefficient of friction 0.005. If the Mach number at the entry is 0.15, determine i) diameter of the duct, ii) length of duct, iii) pressure and temperature at exit and iv) stagnation pressure loss. 8 marks
- b. Differentiate between Fanno flow and isothermal flow. Give one practical example each for Fanno flow and isothermal flow. 6 marks
- 14.a. Explain the phenomenon of choking in Fanno flow. 4 marks
- b. Air enters, a long circular duct of diameter 12 cm and mean coefficient of friction 0.0045, at a Mach number of 0.5, pressure 3.5 bar and temperature 300 K. If the flow is adiabatic throughout the duct, determine i) the length of the pipe required to change the Mach number to 0.6 ii) pressure and temperature of air at $M=0.6$ iii) the length of the pipe required to attain limiting Mach number iv) pressure, temperature and Mach number at the limiting condition 10 marks

MODULE III

- 15.a. Derive an equation describing a Rayleigh curve. Show that at maximum entropy point the flow is sonic. 6 marks

b. Data for entry of air at a constant area duct are $p_1 = 0.35$ bar, $T_1 = 300$ K, velocity of gas $c_1 = 60$ m/s. If 620 kJ/kg of heat is added to the gas in the duct between entry and exit sections, determine at the exit i) pressure ii) temperature iii) Mach number iv) velocity of gas. How much heat is required to accelerate air from initial condition to sonic condition? 8 marks

16.a. Derive an expression for maximum possible heat transfer in Rayleigh flow in terms of Mach number. 7 marks

b. Air at Mach 1.5, pressure 300 kPa and temperature 288 K is brought to sonic velocity in a frictionless constant area duct through heat transfer. Determine the final pressure, temperature and heat added during the process. 7 marks

MODULE IV

17.a. Derive an expression for Mach number downstream of a normal shock 7 marks

b. The ratio of exit to entry area in a subsonic diffuser is 3.3 . The Mach number of a jet of air approaching the diffuser is 2.1 . Stagnation pressure of the jet is 1.1 bar and its static temperature is 330 K. There is a standing normal shock wave just outside the diffuser entry. The flow in the diffuser is isentropic. Determine pressure, temperature and Mach number at the exit of the diffuser. Also find the loss in stagnation pressure of the jet as it passes through the diffuser. 7 marks

18. a. What is an expansion fan? How does it occur in supersonic flow? 5 marks

18b. A stationary normal shock occurs in an air stream when the pressure, temperature and Mach number are 85 kPa, 110 °C and 1.7 respectively. Determine its density after the shock. Compare this value in an isentropic compression through the same pressure ratio. 9 marks

MODULE V

19 a. Explain the working of a shock tube with a neat sketch 8 marks

b. Explain the working of a constant current hot wire anemometer used for flow velocity measurement. 6 marks

20 a. Describe with the aid of a schematic diagram the working of a closed circuit supersonic wind tunnel. 7 marks

b. With a neat sketch explain the working of stagnation temperature probe. 7 marks

Syllabus

MECHANICAL ENGINEERING

Module 1- FUNDAMENTALS OF COMPRESSIBLE FLOW & ISENTROPIC FLOW

Fundamentals of compressible flow: Concept of continuum-system and control volume approach- conservation of mass, momentum and energy- Mach number and its significance- Mach waves- Mach cone and Mach angle- physical difference between incompressible, subsonic, sonic and supersonic flows- static and stagnation states- relationship between stagnation temperature, pressure, density and enthalpy in terms of Mach number- Reference states in compressible fluid flows - adiabatic energy equation-representation of various flow regimes on steady flow adiabatic ellipse.

One Dimensional Isentropic flow: General features of isentropic flow- Comparison of adiabatic and isentropic process- One dimensional isentropic flow in ducts of varying cross-section- nozzles and diffusers- mass flow rate in nozzles- critical properties and choking- area ratio as function of Mach number- Impulse function- operation of nozzle under varying pressure ratios –over expansion and under expansion in nozzles-Applications of convergent divergent nozzles- Use of gas dynamics tables.

Module 2 FANNO FLOW

Flow in constant area duct with friction (Fanno flow): Fanno curve and Fanno flow equations - Fanno line on h-s and p-v diagram- variation of flow properties- variation of Mach number with duct length- Chocking due to friction- isothermal flow in constant area duct with friction- Use of gas dynamics tables.

Module 3 RAYLEIGH FLOW

Flow through constant area duct with heat transfer (Rayleigh Flow): Rayleigh line on h-s and p-v diagram-location of maximum enthalpy point- thermal choking-and maximum heat transfer-variations of flow properties- Use of gas dynamics tables.

Module 4 NORMAL & OBLIQUE SHOCK WAVES

Normal shock Waves: Development of shock wave- governing equations- Strength of shock waves- Normal Shock on T-S diagram -Prandtl-Mayer relation, Rankine-Hugoniot relation- Mach number in the downstream of normal shock- variation of flow parameters across the normal shock -normal shock in Fanno and Rayleigh flows- working formula- curves and tables

Oblique shock waves: weak and strong oblique shocks-shock polar diagram-expansion waves- Reflection and intersection of oblique shocks and expansion waves

Module 5 MEASUREMENT & VISUALIZATION TECHNIQUES

Compressible flow field measurement & visualization - Shadowgraph- Schlieren technique- interferometer- subsonic and supersonic flow measurement (Pressure, Velocity and Temperature) – compressibility correction factor- hot wire anemometer- Rayleigh Pitot tube- wedge probe- stagnation temperature probe- temperature recovery factor –Kiel probe - Wind tunnels – closed and open type- sub sonic – supersonic wind tunnels – shock tube.

Text Books

1. Fundamentals of Compressible flow, S. M. Yahya, New age international Publication, Delhi

2. Fundamentals of compressible fluid dynamics- P. Balachandran, PHI Learning, New Delhi

4. Gas Dynamics, E. Rathakrishnan, PHI Learning Pvt. Ltd MECHANICAL ENGINEERING

5. Gas Dynamics and Jet Propulsion- P. Murugaperumal, Scitech Publication, Chennai.

Data Book

1. Yahya S. M., Gas Tables, New Age International.

2. Balachandran P., Gas Tables, Prentice-Hall of India Pvt. Limited.

Reference Books

1. The dynamics and thermodynamics of Compressible fluid flow Volume-I, Ascher H. Shapiro, the Ronald Press Company, New York.

2. Modern Compressible Flow: With Historical Perspective, John D. Anderson, McGraw-Hill Higher Education

COURSE PLAN

MODULE	TOPICS	HOURS ALLOTTED
1	Concept of continuum-system and control volume approach- conservation of mass, momentum and energy	3-1-0
	Mach number and its significance- Mach waves- Mach cone and Mach angle- physical difference between incompressible, subsonic, sonic and supersonic flows- static and stagnation states- relationship between stagnation temperature, pressure, density and enthalpy in terms of Mach number- stagnation velocity of sound- adiabatic energy equation- representation of various flow regimes on steady flow adiabatic ellipse	2-1-0
	General features of isentropic flow- performance curve- Comparison of adiabatic and isentropic process- One dimensional isentropic flow in ducts of varying cross-section- nozzles and diffusers- mass flow rate in nozzles- critical properties and choking- area ratio as function of Mach number- Impulse function- operation of nozzle under varying pressure ratios –over expansion and under expansion in nozzles-Applications of convergent divergent nozzles-Working charts and gas tables.	4-1-0
2	Fanno curve and Fanno flow equations - Fanno line on h-s and P-v diagram- solution of Fanno flow equations- variation of flow properties- variation of Mach number with duct length- Chocking due to friction- tables and charts for Fanno flow- isothermal flow in constant area duct with friction.	4-2-0
	Flow through constant area duct with heat transfer (Rayleigh Flow): Simple heating relation of a perfect gas- Rayleigh line on h-s and P-v diagram-location of maximum enthalpy point- thermal choking-and maximum heat transfer- variations of flow properties- tables and charts	

3	for Rayleigh flow.	4-2-0
4	Development of shock wave- Thickness of shock wave- governing equations- Strength of shock waves- Normal Shock on T-S diagram - Prandtl-Mayer relation, Rankine-Hugoniot relation- Mach number in the downstream of normal shock	4-1-0
	variation of flow parameters across the normal shock -normal shock in Fanno and Rayleigh flows- working formula- curves and tables	2-1-0
	weak and strong oblique shocks-shock polar diagram-expansion waves- Reflection and intersection of oblique shocks and expansion waves	2-1-0
5	Shadowgraph- Schlieren technique-interferometer	2-0-0
	subsonic and supersonic flow measurement (Pressure, Velocity and Temperature) – compressibility correction factor- hot wire anemometer- Rayleigh Pitot tube- wedge probe- stagnation temperature probe- temperature recovery factor –Kiel probe - Wind tunnels – closed and open type- sub sonic – supersonic wind tunnels – shock tube	3-0-0

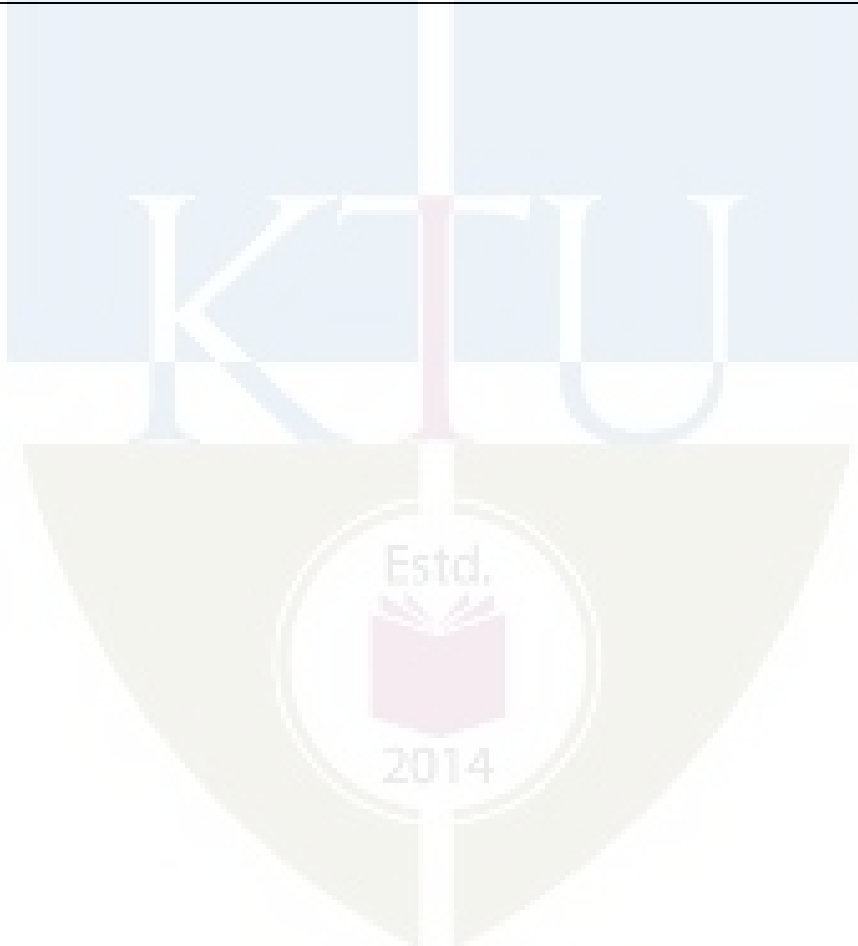

CODE MET398	ADVANCED NUMERICAL CONTROLLED MACHINING	CATEGORY	L	T	P	CREDIT
		VAC	3	1		4

Preamble:

This course will help the student to understand the concept of numerical control and the peripheral requirements of the NC system. It familiarise the different approaches of machining using numerical control and also to make the student familiar to the different programming methods of NC machines.

Prerequisite: Nil

Course Outcomes: After the completion of the course the student will be able to

CO 1	To study the structure of numerical control and its applications
CO 2	To understand the features and control of CNC
CO 3	To write numerical part program of simple machining
CO 4	To familiarize the structure of computer assisted part programming features
CO 5	To study the constructional and automated features of numerical controlled machining

Mapping of course outcomes with program outcomes

	PO 1	PO 2	PO 3	PO 4	PO 5	PO 6	PO 7	PO 8	PO 9	PO 10	PO 11	PO 12
CO 1	2										2	2
CO 2	2				3							2
CO 3	3	2	2								2	1
CO 4	3				2							2
CO 5	3		2		3						1	2

Assessment Pattern

Bloom's Category	Continuous Assessment Tests		End Semester Examination
	1	2	
Remember	10	10	10
Understand	20	20	20
Apply	20	20	70
Analyse			
Evaluate			
Create			

Mark distribution

Total Marks	CIE	ESE	ESE Duration
150	50	100	3 hours

Continuous Internal Evaluation Pattern:

Attendance	: 10 marks
Continuous Assessment Test (2 numbers)	: 25 marks
Assignment/Quiz/Course project	: 15 marks

End Semester Examination Pattern: There will be two parts; Part A and Part B. Part A contain 10 questions with 2 questions from each module, having 3 marks for each question. Students should answer all questions. Part B contains 2 questions from each module of which student should answer any one. Each question can have maximum 2 sub-divisions and carry 14 marks.

Course Level Assessment Questions

Course Outcome 1 (CO1):

1. Describe the structure of NC system
2. Enumerate difference between ordinary and NC Machine tools.
3. What is Machining Capabilities of a CNC Machine,.

Course Outcome 2 (CO2)

1. Differentiate open and closed loop control system
2. Enlist features of CNC and DNC system
- 3 Define the adaptive control system

Course Outcome 3(CO3):

- 1 Define the structure of CNC part programme
2. What is Programming using tool nose radius compensation ,Tools offsets
3. Enlist the procedure of manual Programming for simple parts

Course Outcome 4 (CO4):

1. Enumerate the structure of computer assisted part programming .
2. Generation of NC Programmes through CAD/CAM systems,.

Course Outcome 5 (CO5):

1. Machine structure of CNC machines
2. Constructional features of CNC turning center and CNC machining center
3. Design consideration of CNC machines

MODEL QUESTION PAPER
APJ ABDUL KALAM TECHNOLOGICAL UNIVERSITY
SIXTH SEMESTER B.TECH DEGREE EXAMINATION
Course Code : MET398

Course Name : ADVANCED NUMERICAL CONTROLLED MACHINING
Max. Marks : 100 Duration : 3 Hours

PART – A

(ANSWER ALL QUESTIONS, EACH QUESTION CARRIES 3 MARKS)

- 1 How does the structure of NC/CNC machine tools differ from conventional machine tools.
- 2 Explain clearly the difference between NC and CNC machine
- 3 Differentiate open loop and closed loop system in CNC machine.
- 4 Enumerate advantages and disadvantages of Direct numerical control
- 5 What is GO2 and GO3 in circular interpolation.
- 6 What is tool nose radius compensation and how to use it.
- 7 What is CAPP and discuss the benefits of CAPP
- 8 Discuss the code is used for canned cycle definition
- 9 Explain briefly swarf removal process in CNC machine.
- 10 What are the types of tools holders in CNC machine

PART – B

(ANSWER ONE FULL QUESTION FROM EACH MODULE)

Module- 1

- 11 a) With schematic diagram explain the basic principal of numerical. (8 Marks)
b) Explain the historical development of numerical controlled machining (6 Marks)
- 12 a) Explain the machining capabilities of a CNC machine tool (7 Marks)
b) Enlist and describe the advantages and dis advantages of CNC Machine (7 Marks)

Module-2

- 13 a) Describe the basic system of CNC machine tool (7Marks)
b) Explain programming features of CNC system (7Marks)
- 14 a) What is adaptive control system in CNC machining and what is its benefits (7Marks)
b) Describe the standard controllers of CNC machines (7Marks)

Module-3

MECHANICAL ENGINEERING

- 15 a) Explain the structure of NC part program (7Marks)
b) Describe the various programming functions of NC machining (7Marks)
- 16 a) Explain the fundamental element for developing manual part programme. (7Marks)
b) Describe various G code and M codes of NC programming. (7Marks)

Module-4

- 17 Write the APT program of a given basic geometry element (14Marks)

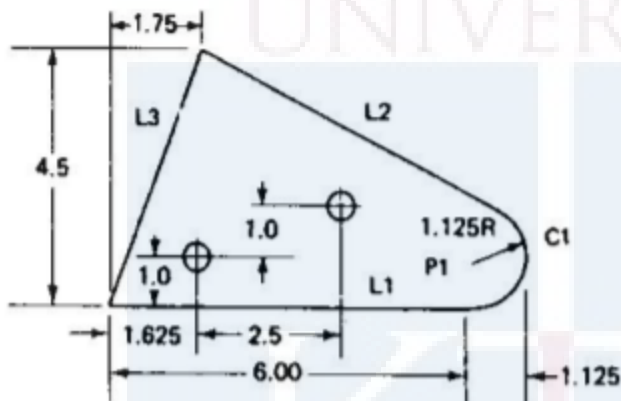

- 18 a) Explain the features CNC post processor. (8Marks)
b) Explain the generation of NC program through CAD/CAM system (6Marks)

Module-5

- 19 a) Explain Automatic tool changers and multiple pallet systems in CNC system(7Marks)
b) Describe the constructional details of CNC turning centre (7Marks)
- 20 a) Explain various tooling requirement of CNC system (6Marks)
b) What is CNC tool holder and what are the different types (8Marks)

Module 1

Principles of Numerical Control Structure of NC systems, Applications of CNC machines in manufacturing, Advantages of CNC machines. Historical developments and future trends. Future of NC Machines, Difference between ordinary and NC Machine tools, Machining Capabilities of a CNC Machine, Methods for improving accuracy and productivity.

Module 2

Control of NC Systems: Classification of CNC control systems Open and Closed loop systems, Types of CNC Machine Tools systems devices, e.g. encoders and interpolators, Features of CNC Systems, Direct Numerical Control (DNC), Standard Controllers and General Programming features available in CNC Systems, Computer Process monitoring and Control. Adaptive control systems.

Module 3

NC Part Programming: Axis identification and coordinate systems ,Structure of CNC part program, Programming codes, Programming for 2 and 3 axis control systems ,Manual part programming for a turning center ,Programming using tool nose radius compensation ,Tools offsets ,Do loops, sub routines and fixed cycles. Manual Programming for simple parts.

Module 4

Computer aided part programming; Tools for computer aided part programming, Computer aided NC Programming in APT language, use of canned cycles, Generation of NC Programmes through CAD/CAM systems, Design and implementation of post processors.

Module 5

Constructional Details of CNC Machines: Machine structure ,Slide –ways ,Motion transmission elements ,Swarf removal and safety considerations ,Automatic tool changers and multiple pallet systems, Sensors and feedback devices in CNC machines ,Constructional detail of CNC turning center and CNC machining center. **Tooling of CNC Machines** Tooling requirements of CNC machines, Pre-set and qualified tools, Work and tool holding devices in CNC machines. Design considerations of CNC machines.

Text Books

1. Radhakrishnan, P., “Computer Numerical Control Machines”, New Central Book Agencies
2. Mikell P. Groover., “ Automation, Production Systems and Computer Integrated Manufacturing”, Prentice Hall.

Reference Books

MECHANICAL ENGINEERING

1 YoramKoren, “Computer Control of Manufacturing Systems”, Tata McGraw Hill Book Co.,2005.

2 HMT, Mechatronics, Tata McGraw-Hill Publishing Company Limited, New Delhi,1998.

Course Contents and Lecture Schedule

No	Topic	No. of lectures
1	Module-1- Principles of Numerical Control	8 Hours
1.1	Structure of NC systems, Applications of CNC machines in manufacturing,	2 Hr
1.2	Advantages of CNC machines. Historical developments and future trends.	1 Hr
1.3	Future of NC Machines,	1 Hr
1.4	Difference between ordinary and NC Machine tools,	1 Hr
1.5	Capabilities of a CNC Machine	1 Hr
1.6	Methods for improving accuracy and productivity	2 Hr
2	Module 2-Control of NC Systems:	8 Hours
2.1	Classification of CNC control systems	1 Hr
2.2	Open and Closed loop systems,	1 Hr
2.3	Types of CNC Machine Tools systems devices, e.g. encoders and interpolators	1 Hr
2.4	Features of CNC Systems,	1 Hr
2.5	Direct Numerical Control (DNC),	1 Hr
2.5	Standard Controllers and General Programming features available in CNC Systems,	2 Hr
2.6	Computer Process monitoring and Control. Adaptive control systems.	1 Hr
3	Module-3- NC Part Programming	9 Hours
3.1	Axis identification and coordinate systems	1 Hr

3.2	Structure of CNC part program, Programming codes	2 Hr
3.3	Programming for 2 and 3 axis control systems	1 Hr
3.4	Manual part programming for a turning center	1 Hr
3.5	,Programming using tool nose radius compensation	1 Hr
3.6	Tools offsets ,Do loops, sub routines and fixed cycles	1 Hr
3.7	Manual Programming for simple parts	2 hr
4	Module-4- Computer aided part programming;	8 Hours
4.1	Tools for computer aided part programming	2 Hr
4.2	Computer aided NC Programming in APT language	2 Hr
4.3	use of canned cycles,	1 Hr
4.4	Generation of NC Programmes through CAD/CAM systems	2 Hr
4.5	, Design and implementation of post processors.	1 Hr
5	Module-5- Constructional Details of CNC Machines: Tooling of CNC Machines	12 Hours
5.1	Machine structure ,Slide –ways ,Motion transmission elements	2 Hr
5.2	Swarf removal and safety considerations	1 Hr
5.3	Automatic tool changers and multiple pallet systems	1 Hr
5.4	Sensors and feedback devices in CNC machines	1 Hr
5.5	Constructional detail of CNC turning center	2 Hr
5.6	CNC machining center and Tooling requirements of CNC machines	1 Hr
5.8	Pre-set and qualified tools and Work and tool holding devices in CNC machines	2 Hr
5.10	Design considerations of CNC machines.	2 Hr